

KAWASAKI GREEN GAS ENGINE

for Marine

Model **L30KG** Series

The **NEW** Generation
with KAWASAKI TECHNOLOGY



Kawasaki Heavy Industries, Ltd.

Gas Turbine & Machinery Company Machinery Division
<http://global.kawasaki.com/en/mobility/marine/machinery/index.html>

Tokyo Head Office / Marine Machinery Sales Dept. / Overseas Sales Section
14-5, Kaigan 1-chome, Minato-ku, Tokyo 105-8315, Japan
Tel: +81-3-3435-2374 Fax: +81-3-3435-2022
E-mail: marine-machinery-sales-e@khi.co.jp

 **GREEN**
Gas Engines

ECOLOGY & HIGH-EFFICIENCY

ECOLOGICAL FRIENDLY ENVIRONMENTALLY FRIENDLY

Kawasaki Green Gas Engine for marine use, model L30KG series (below referred as "L30KG"), developed by original standout technology, can effectively reduce the amount of NOx, SOx and CO₂, and contributes to the improvement of global environment.



Main Particulars

		6L30KG	7L30KG	8L30KG	9L30KG
BORE	mm	300			
STROKE	mm	480			
SPEED	rpm	750			
POWER ¹⁾	kW	2,670	3,115	3,560	4,005
SFGC ³⁾	kJ/kWh	7,200 ^{1),2)}			
WEIGHT	ton	33	37	42	47

ECOLOGY

IMO NOx Tier III compliant without additional devices

NOx/CO₂/SOx emissions from vessels are being controlled tight by IMO (International Maritime Organization) in view of the global ecology. L30KG realizes NOx level below Tier III and minimizes CO₂ by own lean-burn technology. Natural gas as a fuel brings zero SOx emission.

Emissions (for reference)

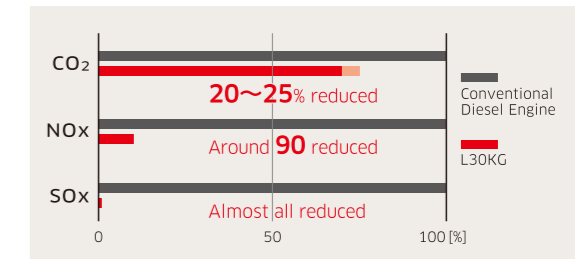

The above chart is the reference value when setting the conventional diesel engine amount of emission to 100%. The approximation was measured from several data.

HIGH-EFFICIENCY

Lowest fuel consumption

L30KG series is newly developed for marine use, based on the sister engines (KG series) servicing in worldwide power plants and fully playing the high efficiency. L30KG realizes the lowest fuel gas consumption rate of 7,200kJ/kWh^{1),2)} for the similar size engines.

SAFETY DESIGN

L30KG series are applicable to gas safety machinery room by double wall piping, double block and bleed valve.

Gas Valve Unit as Option

Gas Valve Unit consists of Shut-off valves, relief valves, and pressure control valve and so on. It is collected in pressure proof container as double wall pipe, and can be located near Gas Engine in machinery room flexibly.

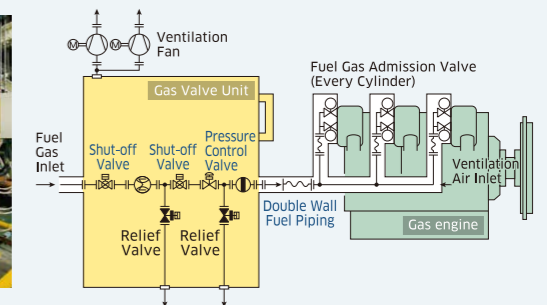

Engine Outline

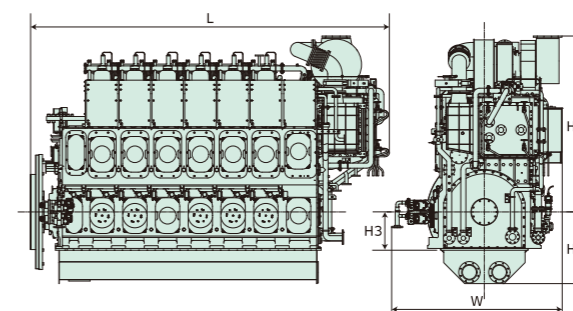

	6L30KG	7L30KG	8L30KG	9L30KG
L [mm]	5,368	6,024	6,679	7,335
W [mm]	2,552			
H1 [mm]	2,632	2,632	2,822	2,822
H2 [mm]	1,072			
H3 [mm]	545			

Application

KAWASAKI engineers your application. Various applications can be made integrating KAWASAKI marine products, such as Controllable Pitch Propeller (CPP), azimuth thruster, hybrid devices, etc.

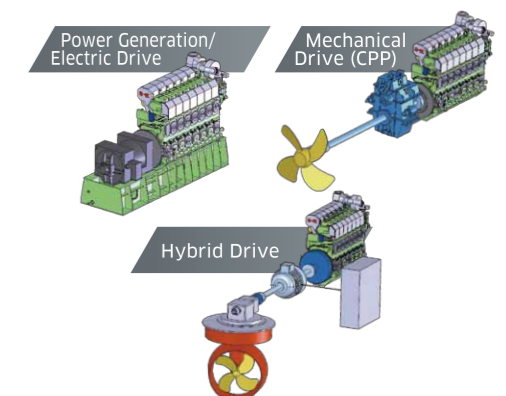

1) Based on ISO3046. Without attached pumps. 2) With applying KAWASAKI specified lub. oil. Tolerance for warranty +5%. 3) SFGC=Specific Fuel Gas Consumption.