

Kawasaki VALVE

KPM

Oil Pressure Regulating Valve

In adopting and using this product	2
Safety Precautions	3
Type Number Index	4



Directional control valve 1-1



Pressure control valve 2-1



Flow control valve 3-1



Sandwich valve 4-1



Logic valve 5-1



Solenoid proportional control valve ... 6-1

Sub-plate Appendix-1

Flange•Nipple Appendix-15

In adopting and using this product

Our products are designed based on sufficient knowledge and long years of experience and are manufactured under strict quality control. However, we ask you to pay attention to the following points in adopting our products.

1

As use conditions of the products listed in this catalog are diversified, the decision of adaptability of the product to the system must be made by a hydraulic system designer or a person who determines the specifications upon conducting the analysis and tests as necessary. Besides, we ask you to study specifications with reference to the latest catalog and material, take the possibility of machine failures into consideration and configure the system.

2

In using the product, please observe safety precautions and use it in a correct use method.

3

Technical information described in this catalog is representative values that explain features and performance of the product, not guaranteed values.

4

If you use the product in the following conditions and environment, please contact us in advance.

- (1) Conditions and environment other than specified specifications
- (2) When the product is used for usage such as nuclear power, aviation, medical service and food
- (3) Usage that is anticipated to have a large impact on persons and properties, especially usage for which safety is required

5

The information described in this catalog may be changed without prior notice. Please contact us for the latest information.

Precautions in use

●Hydraulic oil

Mineral based hydraulic oil, water-glycol based, fatty ester based and phosphate ester based hydraulic oil may be used. However, when phosphate ester based hydraulic oil is used, seal material is special (fluoro rubber). Please specify by adding "-V" at the end of the type indication. When water-glycol based hydraulic oil and fatty ester based hydraulic oil are used, paint is special (epoxy resin). Please specify by adding "-W" at the end of the type indication for the painted products. When using water-glycol based hydraulic oil for a part of types of solenoid valves and valves with a solenoid valve, please specify by adding "-W1" at the end of the type indication. When water-glycol based hydraulic oil is used, rated pressure is 20.6 MPa (210 kgf/cm²). Besides, when the product is used for a long time, sufficient properties control is required.

When using other incombustible hydraulic oil and special hydraulic oil, please contact us.

6

●Viscosity and oil temperature

Use hydraulic oil in the viscosity range of 2.8 to 380 mm²/s (cSt) and in the temperature range of -20 to +70°C (temperature range of 0 to 50°C for water-glycol based hydraulic oil). If you use the product beyond this range, please contact us.

●Valve installation direction

There is no limitation of the valve mounting surface. However, in the no spring type of the solenoid valve and solenoid controlled pilot operated directional valve, install the valve so that the spool is horizontal. In the no spring type of the check valve, install the valve so that the poppet is vertical.

●Mounting surface accuracy

Finish the valve mounting surface to surface roughness of 6.3-Z and flatness of 0.01mm/□100.

●Shipping condition

The adjustment portion of each valve is shipped in the following condition as standard.

Pressure control valve: Adjustment portion fully open (state of minimum pressure)

Flow control valve: Adjustment portion fully closed

In the type selection, we recommend the one indicated in color letters in the type indication explanation.

Safety Precautions

Cautions concerning related regulations





To use the product in this catalog safely, you **MUST** carefully read all Warnings and Cautions in this manual. You **MUST** also observe the related regulations and rules regarding safety.

[Related Standards concerning Safety]





- | | |
|--------------------------------------|--|
| (1) High Pressure Gas Control Law | (4) Explosion class |
| (2) Industrial Safety and Health Law | (5) JIS B8265, B8266 (EN13445) Construction of pressure vessels |
| (3) Fire Service Law | (6) JIS B 8361 (ISO4413) Hydraulic fluid power - General rules relating to systems |

Cautions concerning use of products







(1) Precautions in handling products

- (1)  Caution Use the safety equipment to avoid the injury when you operate the product.
- (2)  Caution Pay enough attention to handling method to avoid pinching hands or back problems that may be caused by heavy weight of the product or handling posture.
- (3)  Caution Do not step on the product, hit it, drop it or give outside force to it. One of these actions may cause the failure of work, damage or oil leakage.
- (4)  Caution Wipe off hydraulic oil on the product or floor completely. Hydraulic oil creates slippery conditions that may result in dropping the product or injuring.





(2) Precautions in installing and removing the product

- (1)  Caution Installation, removal, plumbing and wiring must be done by the certified person.
*CERTIFIED PERSON:
A person who has enough knowledge like a person who is trained by Kawasaki's hydraulic school.
- (2)  Warning Make sure that the power of the hydraulic power unit is turned off and that the electric motor or engine has completely stopped before starting installation or removal. You must also check that the system pressure has dropped to zero.
- (3)  Warning Be sure to turn off the power before starting wiring or other works related to the electric power. Otherwise, you may receive an electric shock.
- (4)  Caution Clean the mounting holes and mounting surface completely. Otherwise you may experience damages or oil leakage caused by insufficient tightening torque or broken seal.
- (5)  Caution Be sure to use the specified bolts and keep the specified tightening torque when you install the product. Usage of unauthorized bolts, lack of torque or excess of torque may create problems such as failure of work, damage and oil leakage.

(3) Warnings and Cautions for operation

- (1)  Danger Never use the product not equipped with anti-explosion protection in the circumstances of possible explosion or combustion.
- (2)  Warning Never remove the protection cover over the rotating part such as motor shaft and pump shaft to avoid injuries by being rolled fingers or cloths in.
- (3)  Warning Stop the operation immediately if you find something wrong such as unusual noise, oil leakage or smoke, and fix it properly. If you continue operating, you may encounter damage, fire or injury.
- (4)  Caution Make sure that plumbing and wiring are correct and all the connection is tightened correctly before you start operating, especially if it is the first run.
- (5)  Caution Use the product under the specification mentioned in the catalog, drawings and specification sheet.
- (6)  Caution Keep your hands and body off the product during the operation as it may become hot due to oil temperature and temperature increase of the solenoid. Otherwise you may suffer burns.
- (7)  Caution Use the proper hydraulic oil, and maintain the contamination in the recommended level. Otherwise the product may not work or be damaged.

(4) Cautions related to maintenance and storage

- (1)  Caution Never modify the product without approval of Kawasaki.
- (2)  Caution Do not disassemble and reassemble the product without approval of Kawasaki. It may cause troubles and failures, or it may not work as specified. If it is necessary by all means to disassemble and reassemble it, it must be done by an authorized person.
- (3)  Caution Keep the product from dust and rust by paying attention to the surrounding temperature and humidity when you transport or store the product.
- (4)  Caution Replacing the seals may be required if you use the product after long time storage.

Type Number Index

3	3RBE10, 20, 30 (Three stage pressure relief valve)	2-27
B	B10 to 30 (Brake valve)	2-54
C	C6 to 30 (Check valve)	1-65
	C52 to 150 (Check valve)	1-69
	CBD6 to 30 (Counterbalance valve)	2-61
	CFW-B15-D (Controller for DC power supply double solenoid with LVDT feedback)	6-39
	CF-B15-D (Controller for DC power supply single solenoid with LVDT feedback)	6-38
	CH6 to 30 (Pilot operated check valve)	1-73
	CH52 to 150 (Pilot operated check valve)	1-77
	CHY6 to 30 (Pilot operated check valve)	1-73
	CHY52 to 150 (Pilot operated check valve)	1-77
	CS6, 10 (Selector valve)	5-25
	CW-B10-A (Controller for AC power supply double solenoid)	6-35
	CW-B15-D (Controller for DC supply double solenoid)	6-37
	C-B10-A (Controller for AC power supply double solenoid)	6-34
	C-B15-D (Controller for DC power supply single solenoid)	6-36
D	DDP (Solenoid proportional control valve - Direct operated type)	6-20
	DDPL6 (Solenoid proportional control valve - Direct operated type, with LVDT)	6-26
	DE5 (Solenoid operated directional valve)	2-14
	DE6 (Solenoid operated directional valve)	1-2
	DE10 (Solenoid operated directional valve)	1-11
	DEH16, 22, 32 (Solenoid controlled pilot operated directional valve)	1-20
	DEH52 (Solenoid controlled pilot operated directional valve)	1-32
	DG6 (Pressure gauge valve)	1-80
	DH6, 10 (Pilot operated directional valve)	1-40
	DH16, 22, 32 (Pilot operated directional valve)	1-44
	DH52 (Pilot operated directional valve)	1-50
	DHP16, 22 (Solenoid proportional control valve - 2-stage amplifier type)	6-22
	DHPL16 (Solenoid proportional control valve - 2-stage amplifier type, with LVDT)	6-29
	DM6, 10 (Manual selector valve)	1-55
	DM16, 22, 32 (Manual selector valve)	1-59
F	F1M10, 20, 30 (Throttle valve - Cartridge type)	3-8
	F5, 10 (Precision throttle valve)	3-18
	FC1M10, 20, 30 (Slow return check valve - Cartridge type)	3-14
	FJC5, 10, 16 (Temperature and pressure compensated flow regulating valve)	3-22
	FJC30 (Temperature and pressure compensated flow regulating valve)	3-25
	FK10, 16 (Three-way flow regulating valve)	3-27
K	K4 LA (Manual selector valve with 4 port detent)	1-64
	KC, KWC (Controller for DC power supply single and double solenoids, small and inexpensive type)	6-40
	KDZ15 to 40 (Counterbalance valve - with unload function)	2-64
	KLD16 to 100 (Logic valve)	5-2
	KMK (Slow return check valve - Gasket type)	3-16

L

LPR16 to 63 (Logic element for pressure control)	5-28
LR16 to 80 (Logic element for pressure control)	5-28
LU16 to 100 (Logic valve cover)	5-2

P

PRB10, 20, 30 (Pressure reducing valve - Balanced piston type pilot operated)	2-51
PRD6, 10 (Pressure reducing valve - Direct operated type)	2-48
PRBP10, 20, 30 (Pressure reducing valve of solenoid proportional balanced piston type)	6-16
PRDP1M6 (Solenoid proportional pilot pressure reducing valve - Direct operated type)	6-13
PRDP6 (Solenoid proportional pilot pressure reducing valve - Direct operated type)	6-10
PU10, 20, 30 (Unloading relief valve)	2-32
PU35 (Unloading relief valve)	2-37
PUE10, 20, 30 (Unloading relief valve)	2-32

R

RB1M6C, 10C (Relief valve - Balanced piston cartridge type pilot operated)	2-30
RB10, 20, 30 (Relief valve - Balanced piston type pilot operated)	2-10
RB35 (Relief valve - Balanced piston type pilot operated)	2-17
RB52, 82 (Relief valve - Balanced piston type pilot operated)	2-22
RBE10, 20, 30 (Relief valve - Balanced piston type pilot operated)	2-10
RBE35 (Relief valve - Balanced piston type pilot operated)	2-17
RBE52, 82 (Relief valve - Balanced piston type pilot operated)	2-22
RBP10 to 35 (Solenoid proportional balanced piston type relief valve)	6-5
RD6 to 30 (Relief valve - Direct operated type)	2-2
RDPV5 (Solenoid proportional direct operated type relief valve - for vent control)	6-2
RDV6, 10 (Relief valve - Direct operated type for vent control)	2-4
RDV1M6 (Relief valve for panel mounted vent control)	2-4

S

SB10, 20, 30 (Sequence valve - Balanced piston type pilot operated)	2-43
SBE10, 20, 30 (Sequence valve - Balanced piston type pilot operated)	2-43
SD6, 10 (Sequence valve - Direct operated type)	2-40
S-(2)C6, 10 (Sandwich type check valve)	4-2
S-(2)CH6 to 22 (Sandwich type pilot operated check valve)	4-5
S-(2)RB6, 10 (Sandwich type relief valve)	4-9
S-(2)T6, 10 (Sandwich type throttle valve)	4-20
S-(2)TC6 to 22 (Sandwich type slow return check valve)	4-26
S-4C5, 10, 16 (Sandwich type check valve block)	4-33
S-PRD6, 10 (Sandwich type pressure reducing valve - Direct operated type)	4-16
S-SD6, 10 (Sandwich type sequence valve - Direct operated type)	4-12

T

T1M6 to 30 (Variable throttle valve)	3-2
T1M52 to 102 (Throttle valve)	3-6
T6 to 30 (Throttle valve)	3-4
TC1M52 to 102 (Slow return check valve)	3-12
TC6 to 30 (Slow return check valve)	3-10

Z

ZA10, 20, 30 (Sandwich type check valve block)	4-36
ZNS5, 6, 10 (Sandwich type shock damping valve)	4-39

Directional control valve

	Page
Solenoid operated directional valve ····· DE6	1-2
Solenoid operated directional valve ····· DE10	1-11
Solenoid controlled pilot operated directional valve (1) · DEH	1-20
Solenoid controlled pilot operated directional valve (2) · DEH	1-32
Pilot operated directional valve (1) ····· DH	1-40
Pilot operated directional valve (2) ····· DH	1-44
Pilot operated directional valve (3) ····· DH	1-50
Manual selector valve (1) ··········· DM	1-55
Manual selector valve (2) ··········· DM	1-59
Manual selector valve - KLA type ········· K4LA	1-64
Check valve (1) ··················· C	1-65
Check valve (2) ··················· C	1-69
Pilot operated check valve (1) ····· CH/CHY	1-73
Pilot operated check valve (2) ····· CH/CHY	1-77
Pressure gauge valve ··············· DG6	1-80

In the type selection, we recommend the one indicated in color letters in the type indication explanation.

Solenoid operated directional valve

DE6

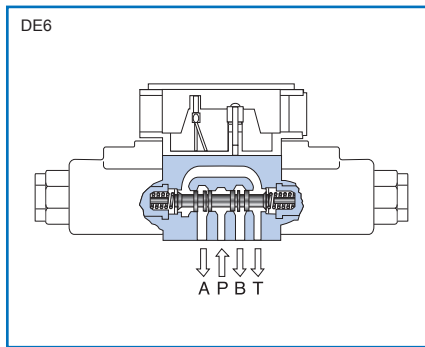
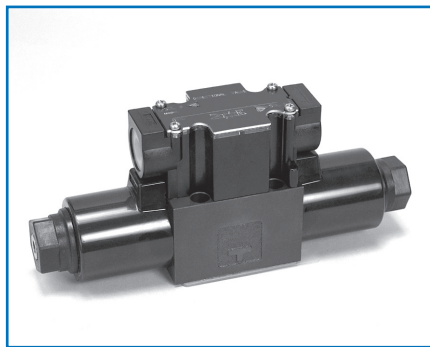

Overview

This solenoid operated directional valve is used for controlling start and stop, and movement direction of the hydraulic system with electrical signals.

Features

1. This valve is resistant to contamination and provides stable operation.
2. A wide variety of options are available.

Type indication

DE6P - 30 - 204 - WD24AL - P08 -

Solenoid operated directional valve

Nominal dimension
6

Connection method
P=Gasket connection type

Series number: 30

Position holding method
1 = 2 position, no spring type (with detent)
2 = 2 position, spring offset type
or
3 position, spring center type

Spool type
*Refer to "Spool type symbols".

Solenoid type
W = Wet type (with standard emergency manual operation)

Input power supply
A = Alternating current
D = Direct current
R = AC/DC conversion

Input voltage

Type of hydraulic oil
No symbol = Mineral based hydraulic oil
Fatty ester based hydraulic oil
Water-glycol based hydraulic oil
V = Phosphate ester based hydraulic oil

Presence/absence of P port restriction
No symbol = No restriction
P08 = Restriction contraction diameter ϕ 0.8 mm
P10 = Restriction contraction diameter ϕ 1.0 mm
P12 = Restriction contraction diameter ϕ 1.2 mm
P15 = Restriction contraction diameter ϕ 1.5 mm
P20 = Restriction contraction diameter ϕ 2.0 mm
P25 = Restriction contraction diameter ϕ 2.5 mm
P30 = Restriction contraction diameter ϕ 3.0 mm
P40 = Restriction contraction diameter ϕ 4.0 mm

Electric connection symbol

Symbol	Explanation	Input power supply		
		A	D	R
AL	Integrated terminal box with lamp	○	○	○
B	With DIN connector	○	○	—
C	With DIN large connector	○	○	○
CL	With DIN large connector and lamp	○	○	—
F	With DIN connector (G1/2)	○	○	—

Direct current D	Alternating current A	AC/DC conversion R
	100 : 100V-50/60Hz 110V-60Hz	
12 : 12V 24 : 24V 48 : 48V	120 : 110V-50Hz 120V-50/60Hz	100 : 100V-50/60Hz 200 : 200V-50/60Hz
	200 : 200V-50/60Hz 220V-60Hz	
	240 : 220V-50Hz 240V-50/60Hz	

*For other power supply voltage, please contact us.

Spool type symbol

2 position valve

Number of positions	Position holding method	Spool type symbol	Hydraulic symbols	Transient state	
2 positions	2 (Spring offset type)				
		01			
		03			
		04			
		02			
	25				
	1 (No spring type with detent)				
		01			
		03			
04					

3 position valve

Number of positions	Position holding method	Spool type symbol	Hydraulic symbols	Transient state
3 positions	1 (Spring center type)			
		05		
		06		
		07		
		08		
		10		
		12		
		13		
		16		
		17		
		21		
		22		

- When neutral position and one side position of the 3 position valve are used together

With reference to the 3 position valve, two types of the 2 position valve are available: the valve that uses the neutral position and sol.a excitation position of the 3 position valve (2**A) and the one that uses the neutral position and sol.b excitation position (2**B).

Number of positions	Position holding method	Spool type symbol	Hydraulic symbols
2 positions	2 (Spring offset type)		
		05A	
		05B	
		06A	
		06B	
		07A	
		07B	
		08A	
		08B	
		10A	
10B			

Specifications

Nominal dimension		6	
Maximum working pressure MPa (kgf/cm ²)	Port A, B, P	35 (357)	
	Port T	21 (214)	
Maximum switching frequency Number of times/min	AC, DC	300	
	AC/DC conversion	120	
Switching time ms (Note 1)	Solenoid excitation	AC	15
		DC	48
		AC/DC conversion	50
	Solenoid demagnetization	AC	23
		DC	19
		AC/DC conversion	100
Maximum ambient temperature °C		50	
Dust proof and water proof properties		JIS C0920 IP65 (Dust proof and water-jets-proof type)	
Mass kg	Single solenoid type	AC	1.4
		DC	
		AC/DC conversion	
	Double solenoid type	AC	1.85
		DC	
		AC/DC conversion	

(Note 1) Switching time varies slightly depending on use conditions.

Sub-plate

Valve type	Sub-plate type	Connection diameter	Mass
DE6P	P-DE6R14-0	Rc 1/4	1.0kg
	P-DE6G14-0	G 1/4	
	P-DE6R38-0	Rc 3/8	1.3kg
	P-DE6G38-0	G 3/8	

When you use a sub-plate, please place an order for the above sub-plate type.

For the dimension drawing, refer to page 11 of the appendix.

Accessories

● Mounting bolt

Type	Hexagon socket head cap thread	Quantity	Tightening torque N·m (kgf·cm)
DE6P	M5×45L	4 pcs.	6.4 ± 0.5 (65 ± 5)

Solenoid specifications

Solenoid type	Power supply	Symbol	Rated voltage V	Frequency Hz	Working voltage range V	Current value at rated voltage		Energized time	Type of coil insulation		
						Holding current A	Starting current A				
Oil immersion type	Alternating current A	A100	100	50	80 to 110	0.51	2.42	Continuous rating	H type		
				60		90 to 120	0.37			2.14	
			110	0.44	2.35						
		A120	120	50	96 to 132	0.42	2.02				
				60	108 to 144	0.31	1.78				
		A200	200	50	160 to 220	0.25	1.21				
					60	180 to 240	0.19			1.07	
				220			0.22			1.18	
		A240	240	50	192 to 264	0.21	1.01				
					60	216 to 288	0.15			0.89	
				Direct current D		D12	12			—	10.8 to 13.2
		D24	24		21.6 to 26.4						1.23
	D48	48	43.2 to 52.8		0.61						
	AC/DC conversion R	R100	100	50/60	90 to 110	0.33	—				
						R200				200	180 to 220

Connection method

Detail of terminal block

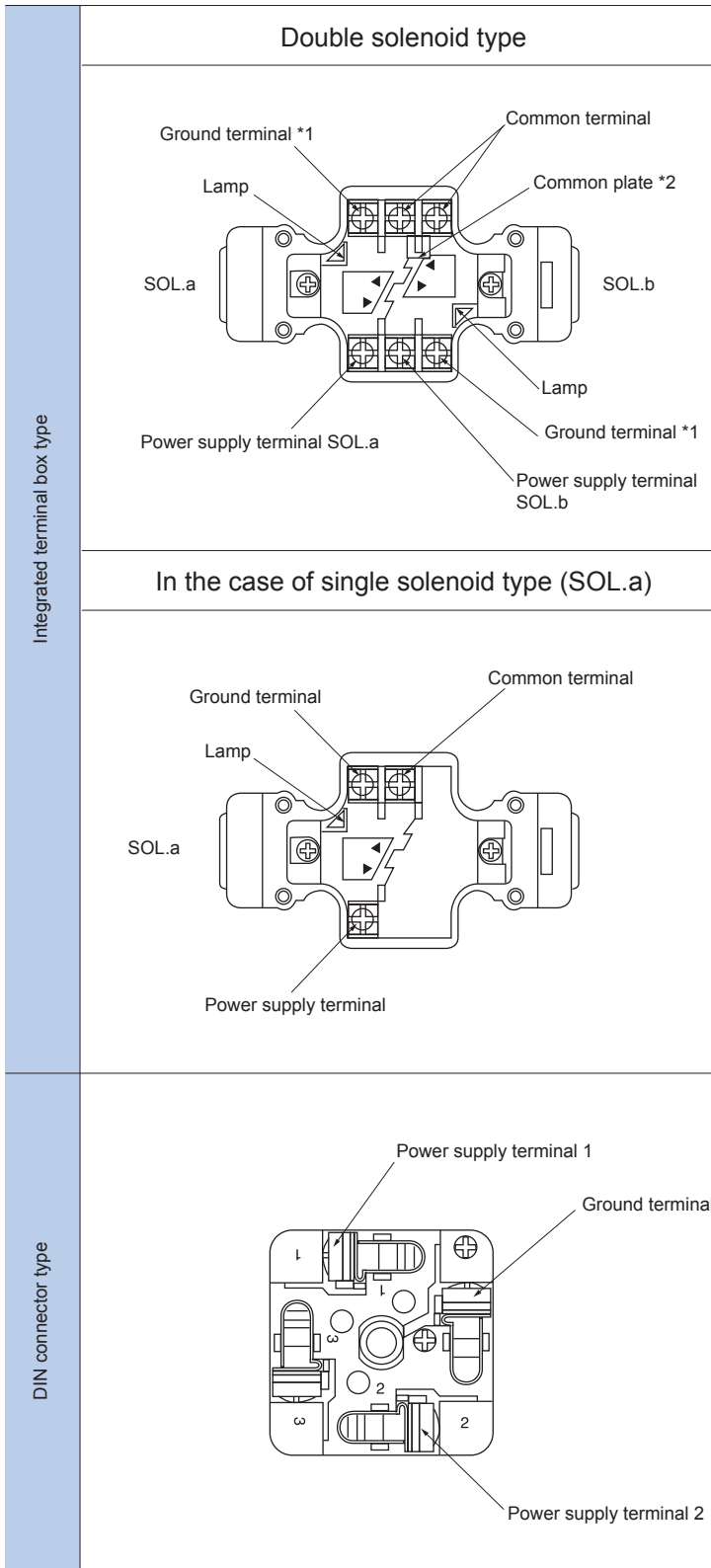

- *1 There are two ground terminals and either of the two may be used.
- *2 If a common plate is not necessary, remove the common plate for use.
- *3 There is no polarity in a DC solenoid either. However, there is polarity in a DIN large connector with a lamp with voltage specifications of DC48 V or less.

Electric circuit diagram (in the case of single solenoid type)

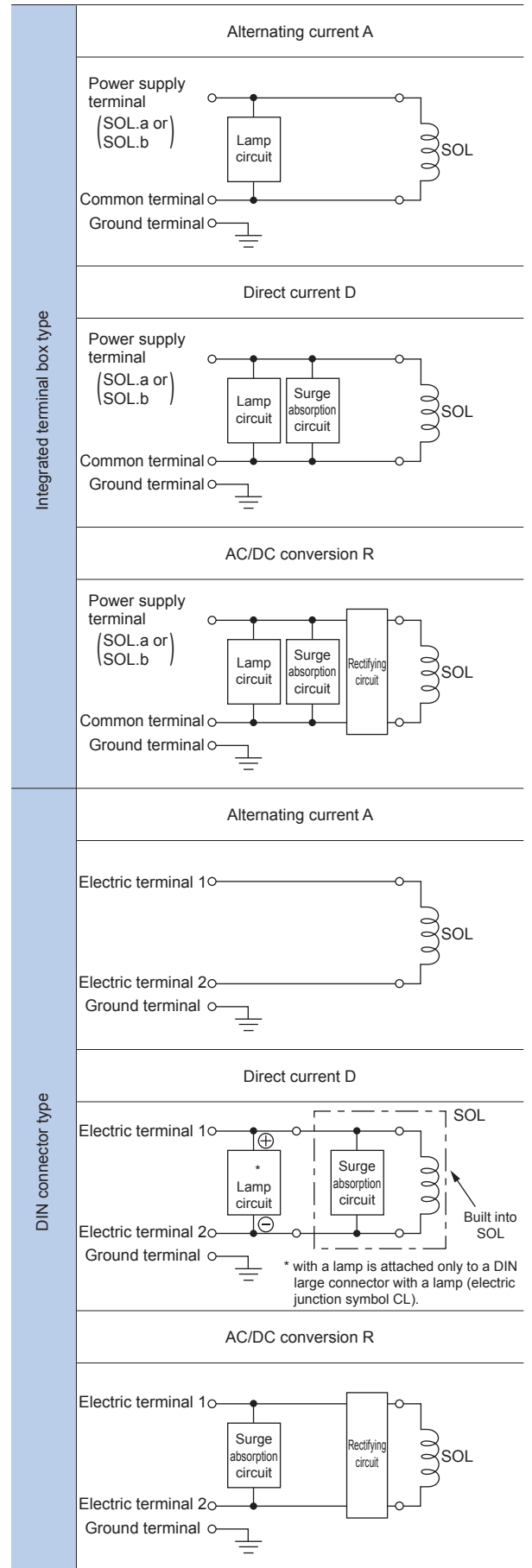

Maximum flow rate

● With AC solenoid DE6P-30***-WA*

Number of positions	Position holding method	Spool type symbol	Hydraulic symbols	Maximum flow rate L/min														
				Flow direction P→A→B→T P→B→A→T					Flow direction of oil P→A					Flow direction of oil P→B				
				Working pressure MPa (kgf/cm ²)					Working pressure MPa (kgf/cm ²)					Working pressure MPa (kgf/cm ²)				
				10 (102)	16 (163)	25 (255)	31.5 (321)	35 (357)	10 (102)	16 (163)	25 (255)	31.5 (321)	35 (357)	10 (102)	16 (163)	25 (255)	31.5 (321)	35 (357)
3 positions	2 (Spring center type)	05		100	100	100	100	100	100 (43)	100 (41)	80 (21)	60 (17)	38 (15)	100 (43)	100 (41)	80 (21)	60 (17)	38 (15)
		08		100 (80)	100 (80)	100 (80)	100 (77)	100 (77)	70 (46)	70 (46)	70 (46)	70 (46)	70 (46)	70 (46)	70 (46)	70 (46)	70 (46)	70 (46)
		10		90	90	90 (22)	90 (18)	35 (11)	100 (38)	76 (28)	67 (15)	57 (10)	35 (7)	100 (38)	76 (28)	67 (15)	57 (10)	35 (7)
		17		85	85	85 (30)	80 (15)	25 (10)	70 (26)	50 (24)	32 (16)	22 (13)	18 (10)	70 (26)	50 (24)	32 (16)	22 (13)	18 (10)
		07		40 (19)	40 (19)	40 (18)	40 (18)	40 (18)	52 (30)	52 (30)	47 (30)	47 (30)	47 (30)	52 (30)	52 (30)	47 (30)	47 (30)	47 (30)
		13		100	100	100	100	100	20	15	10	10	8	20	15	10	10	8
		21		100	100 (63)	100 (33)	100 (27)	100 (50)	100 (37)	100 (20)	78 (16)	62 (13)	100 (50)	100 (37)	100 (20)	78 (16)	62 (13)	
		12		100	100 (63)	100 (33)	100 (27)	100 (50)	100 (37)	100 (20)	78 (16)	62 (13)	100 (50)	100 (37)	100 (20)	78 (16)	62 (13)	
2 positions	2 (Spring offset type)	04		85	85	85	85	85	20	16	16	15	13	85 (63)	80 (50)	63 (40)	44 (32)	44 (32)
		03		70	70	70	70	70	50	50	50	50	50	80 (70)	80 (70)	80 (70)	80 (70)	80 (70)
		01		—	—	—	—	—	26	17	13	11	10	80 (50)	70 (40)	60 (20)	45 (10)	30 (10)
	1 (No spring type with detent)	04		80	80	80	80	80	45	45	45 (21)	45 (16)	38 (13)	50	50 (45)	50 (42)	45 (40)	45 (40)

(Note) The relationship between the maximum flow rate and the frequency and voltage in the above table is as shown below.

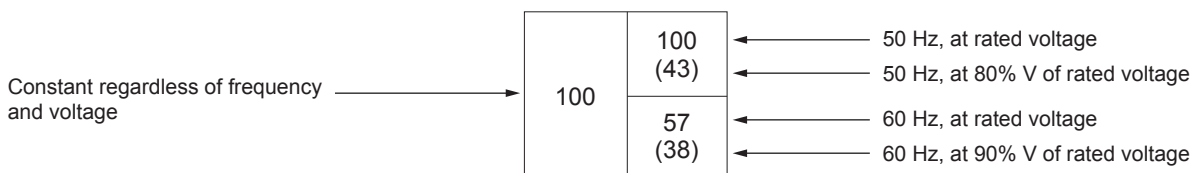

Maximum flow rate

● With DC solenoid DE6P-30***-WD*

With AC/DC conversion type solenoid DE6P-30***-WR*

Number of positions	Position holding method	Spool type symbol	Hydraulic symbols	Maximum flow rate L/min														
				Flow direction P→A→B→T P→B→A→T					Flow direction of oil P→A					Flow direction of oil P→B				
				Working pressure MPa (kgf/cm ²)					Working pressure MPa (kgf/cm ²)					Working pressure MPa (kgf/cm ²)				
				10 (102)	16 (163)	25 (255)	31.5 (321)	35 (357)	10 (102)	16 (163)	25 (255)	31.5 (321)	35 (357)	10 (102)	16 (163)	25 (255)	31.5 (321)	35 (357)
3 positions	2 (Spring center type)	05		100	100	100	100	100	100	45	28	25	22	100	45	28	25	22
				55	35	23	19	17	55	35	23	19	17					
		08		100	100	100	100	100	78	78	78	78	75	78	78	78	78	75
				80	80	80	80	80	70	70	70	70	70	70	70	70	70	70
		10		90	90	90	50	38	100	58	38	31	29	100	58	38	31	29
				42	26	20	62	48	30	25	23	62	48	30	25	23		
		17		85	85	65	40	33	85	52	30	26	24	85	52	30	26	24
				45	30	26	65	36	25	21	19	65	36	25	21	19		
07		32	32	32	32	32	52	44	44	44	44	52	44	44	44	44		
		28	28	28	28	28	42	38	38	38	38	42	38	38	38	38		
13		100	100	100	100	100	20	15	10	10	8	20	15	10	10	8		
21		85	85	85	80	40	100	56	36	28	24	100	56	36	28	24		
		35	23	20	74	43	28	20	19	74	43	28	20	19				
12		85	85	85	80	40	100	56	36	28	24	100	56	36	28	24		
		35	23	20	74	43	28	20	19	74	43	28	20	19				
2 positions	2 (Spring offset type)	04		80	80	80	80	80	20	16	16	15	13	46	31	24	22	22
				32	23	19	18	18	32	23	19	18	18					
		03		70	70	70	70	70	50	50	50	50	50	75	75	75	75	75
	01		-	-	-	-	-	26	17	13	11	10	53	35	23	19	17	
1 (No spring type with detent)	04		75	75	75	75	75	45	45	40	30	27	50	50	50	45	45	
			70	70	70	70	70	30	25	22	45	42	40	40				

(Note) The relationship between the maximum flow rate and the voltage in the above table is as shown below.

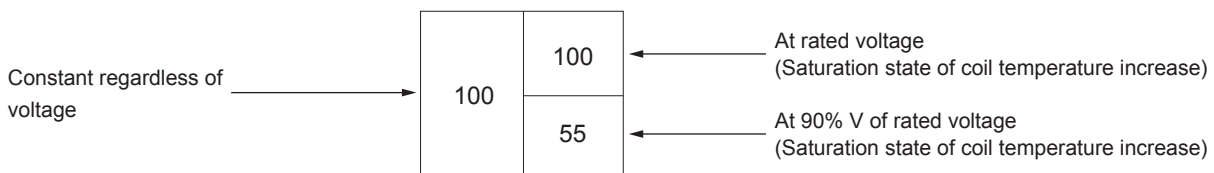

Pressure drop characteristics (viscosity 36 mm²/s (cSt))

DE6

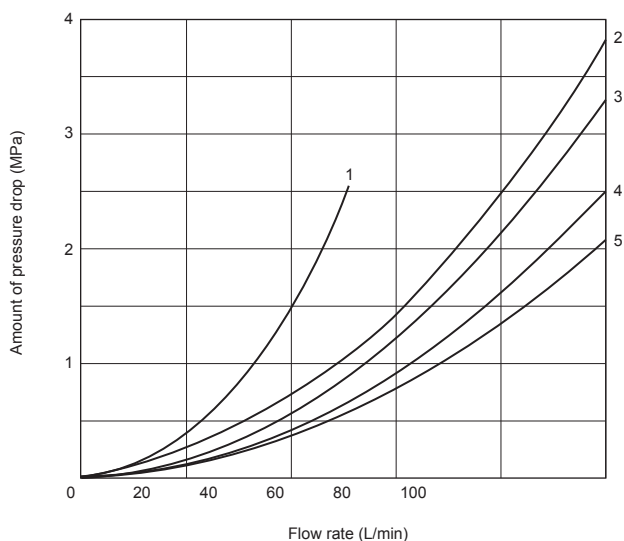

Spool holding method	Direction of flow				
	P→A	B→T	P→B	A→T	P→T
205	4	4	4	4	—
208	5	5	5	5	2
210	4	4	4	4	—
223	4	4	4	4	—
207	1	1	1	1	2
213	5	3	5	3	—
221	4	5	4	4	—
212	4	4	4	5	—
104	5	4	5	4	—
204	5	4	5	4	—
203	5	5	5	5	—
201	5	—	4	—	—

Option

The following options are available in addition to the standard items.

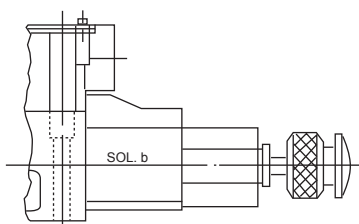

<With push button lock>

At the time of adjustment, the valve can be held at the switched position even if the solenoid in an emergency is not energized.

When placing an order, add a special type, -07, at the end of the type.

Precautions in use

- **Mounting posture**
When using the valve of the no spring detent type without excitation, mount the solenoid horizontally so that the detent effect is securely obtained. For the valve of other type, there is no limitation of mounting posture.
- **Switching of solenoid**
Be sure to deenergize one solenoid before energizing the other solenoid.
- **Tank port**
Do not connect the tank port to a conduit where surge pressure is generated.
Be sure to immerse the end of the tank line piping into oil.
- **Manual pin operating force**
Be careful that the operation of the manual pin is difficult if the back pressure of the tank line becomes high.

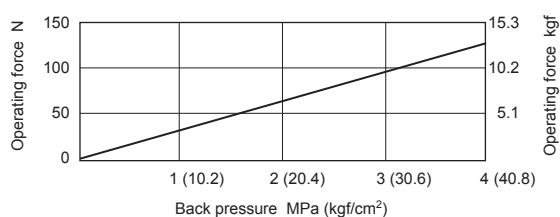

Dimension drawing

● DE6P (Integrated terminal box type)

● With AC solenoid

Machining dimension of manifold

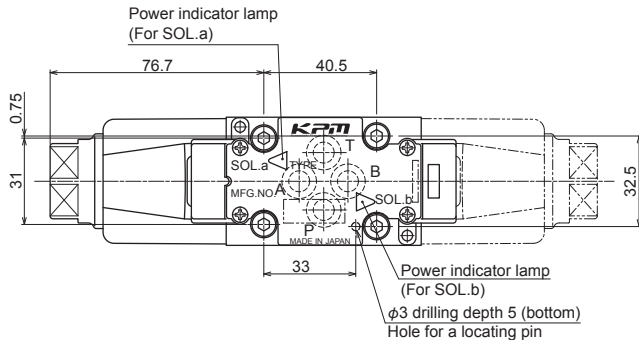
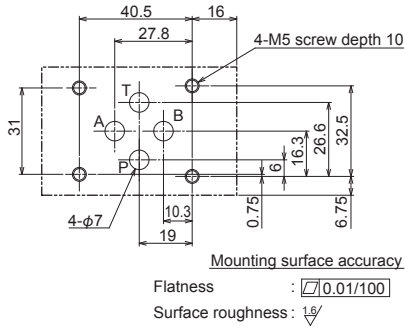

Space for removal and installation of solenoid 45.5 (for both sides)

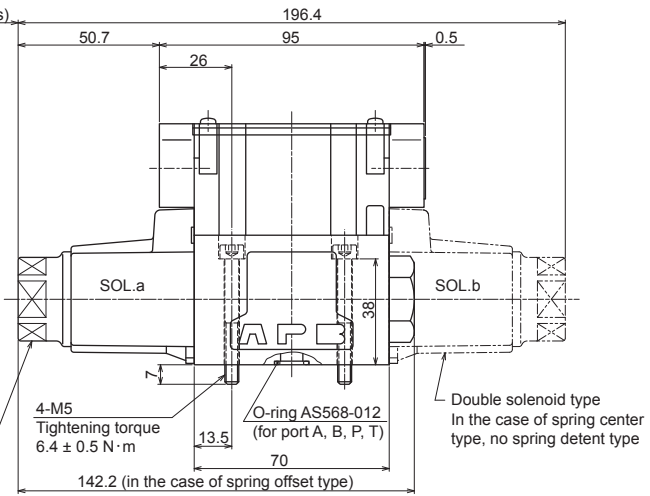
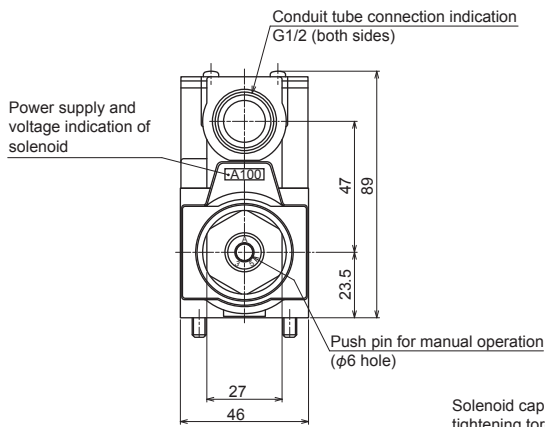

● With DC solenoid

● With AC/DC conversion type solenoid

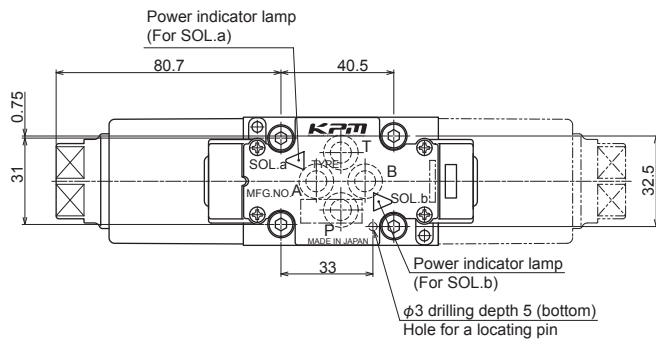

Space for removal and installation of solenoid 50 (for both sides)

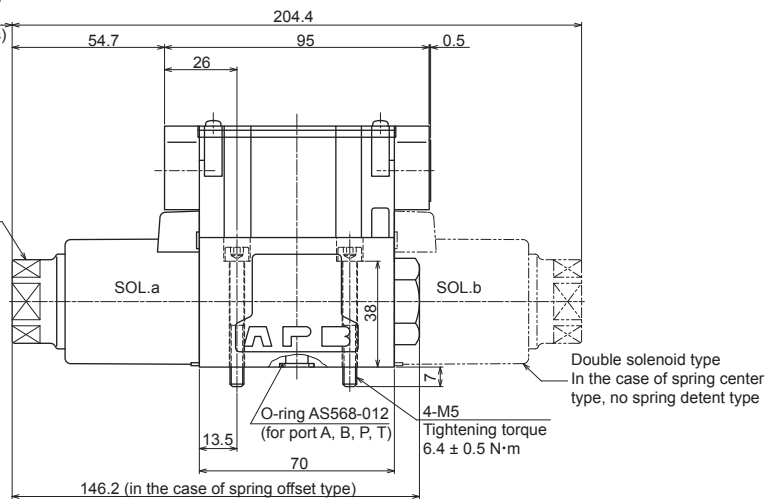
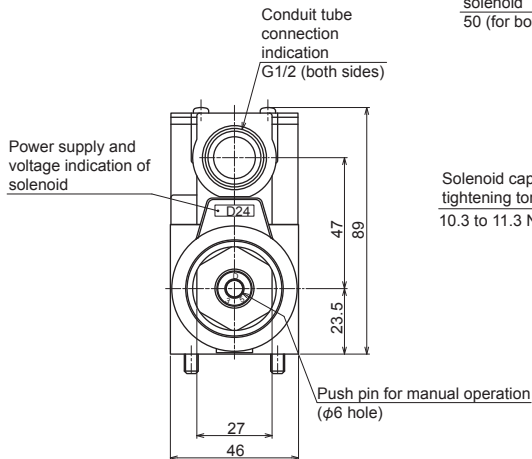

● DE6P (DIN connector type, DIN large connector type, DIN large connector type with power indicator lamp)

● With AC solenoid

Machining dimension of manifold

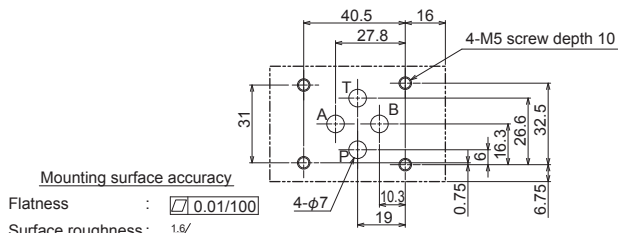

Mounting surface accuracy

Flatness : $\sqrt[0.01/100]$

Surface roughness : $\sqrt[1.6]$

The position can be changed by loosening the solenoid cap. After changing the position, be sure to tighten the cap.

Power supply and voltage indication of solenoid

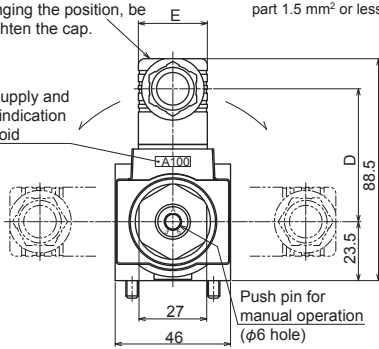

PG11
Outer diameter of connection cable $\phi 8$ to 10 mm
Cross section of connection part 1.5 mm² or less

Space for removal and installation of solenoid
45 (for both sides)

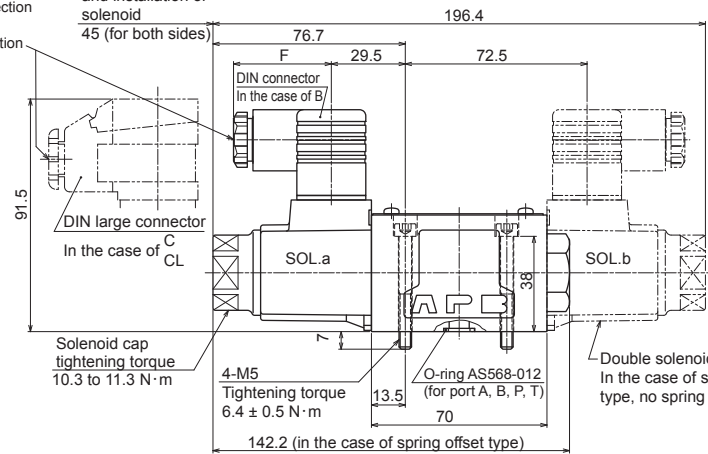
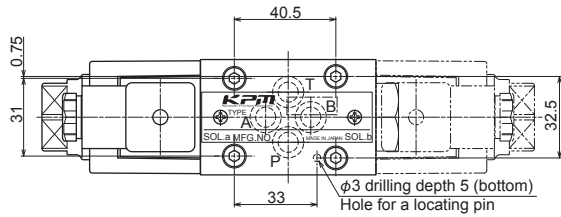

Type of connector	D	E	F
DIN connector (B)	53	27.5	39
DIN large connector (C, CL)	46.1	34	53

● With DC solenoid

● With AC/DC conversion type solenoid

The position can be changed by loosening the solenoid cap. After changing the position, be sure to tighten the cap.

Power supply and voltage indication of solenoid

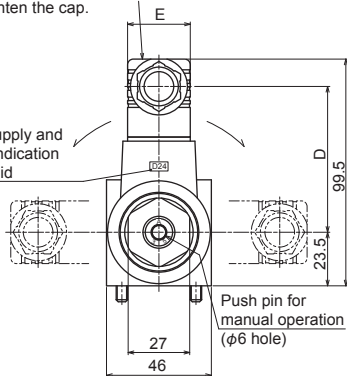

PG11
Outer diameter of connection cable $\phi 8$ to 10 mm
Cross section of connection part 1.5 mm² or less

Space for removal and installation of solenoid
50 (for both sides)

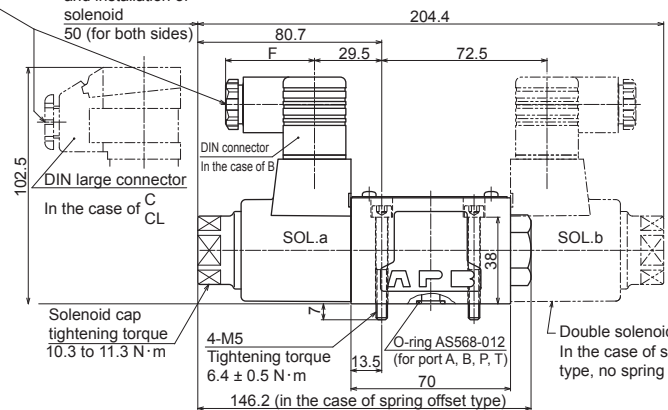
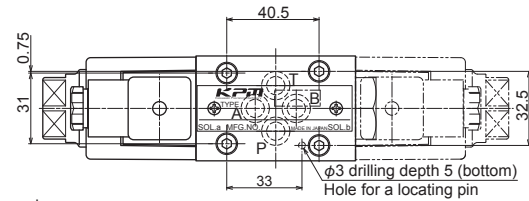

Type of connector	D	E	F
DIN connector (B)	64	27.5	39
DIN large connector (C, CL)	57.2	34	53

● DE6P (with push button lock)

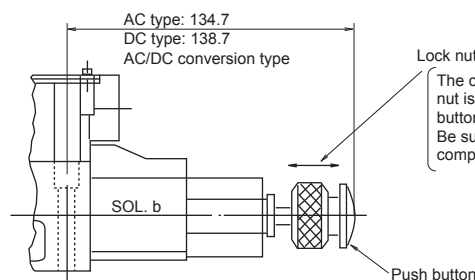

The connector is locked when the lock nut is turned clockwise with the push button pushed in. Be sure to loosen the lock nut completely during energization.

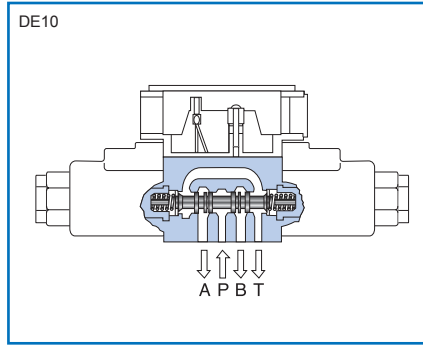
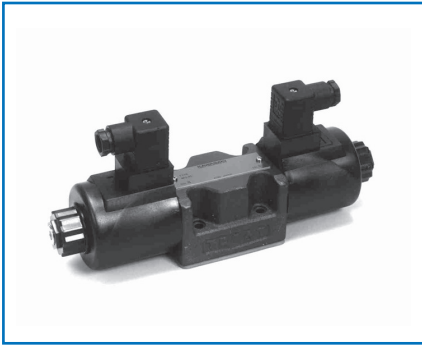

Overview

This solenoid operated directional valve is used for controlling start and stop, and movement direction of the hydraulic system with electrical signals.

Features

1. This valve is resistant to contamination and provides stable operation.
2. A wide variety of options are available.
3. Explosion proof solenoids are also available.

Type indication

DE 10 P - 20 - 2 04 - W D 24 AL - P08 -

Solenoid operated directional valve

Nominal dimension
10

Connection method
P = Gasket connection type

Series number: 20

Position holding method
1 = 2 position, no spring type (with detent)
2 = 2 position, spring offset type
or
3 position, spring center type

Spool type
* Refer to "Spool type symbols".

Solenoid type
W = Wet type (with standard emergency manual operation)
* (For the explosion proof type, please contact us.)

Input power supply
A = Alternating current
D = Direct current
R = AC/DC conversion

Type of hydraulic oil

- No symbol = Mineral based hydraulic oil
- Fatty ester based hydraulic oil
- Water-glycol based hydraulic oil
- V = Phosphate ester based hydraulic oil

Presence/absence of P port restriction

- No symbol = No restriction
- P08 = Restriction contraction diameter ϕ 0.8 mm
- P10 = Restriction contraction diameter ϕ 1.0 mm
- P12 = Restriction contraction diameter ϕ 1.2 mm
- P15 = Restriction contraction diameter ϕ 1.5 mm
- P20 = Restriction contraction diameter ϕ 2.0 mm
- P25 = Restriction contraction diameter ϕ 2.5 mm
- P30 = Restriction contraction diameter ϕ 3.0 mm
- P40 = Restriction contraction diameter ϕ 4.0 mm

Electric connection symbol

Symbol	Explanation	Input power supply		
		A	D	R
AL	Integrated terminal box with lamp	○	○	○
B	With DIN connector	○	○	—
C	With DIN large connector	○	○	○
CL	DIN large connector with lamp	○	○	—

Input voltage

Input voltage	Alternating current A		Direct current D		AC/DC conversion R	
	V	Hz	V	V	V	Hz
100	100V-50/60Hz	60	12	12V	100	100V-50/60Hz
120	110V-60Hz	60	24	24V	120	120V-50/60Hz
	110V-50Hz	50	48	48V	200	200V-50/60Hz
200	120V-50/60Hz	60	100	100V	220	220V-50/60Hz
	200V-50/60Hz	60	110	110V		
240	220V-60Hz	60	200	200V		
	220V-50Hz	50	220	220V		
	240V-50/60Hz	60				

Spool type symbol

2 position valve

Number of positions	Position holding method	Spool type symbol	Hydraulic symbols	Transient state
2 positions	2 (Spring offset type)			
		01		
		03		
		04		
		02		
	25			
	1 (No spring type with detent)			
		01		
		03		
04				

3 position valve

Number of positions	Position holding method	Spool type symbol	Hydraulic symbols	Transient state
3 positions	2 (Spring center type)			
		05		
		06		
		07		
		08		
		09		
		10		
		12		
		13		
		16		
		17		
		21		
		22		

When neutral position and one side position of the 3 position valve are used together

With reference to the 3 position valve, two types of the 2 position valve are available: the valve that uses the neutral position and sol.a excitation position of the 3 position valve (2**A) and the one that uses the neutral position and sol.b excitation position (2**B).

Number of positions	Position holding method	Spool type symbol	Hydraulic symbols
2 positions	2 (Spring offset type)		
		05A	
		05B	
		06A	
		06B	
		07A	
		07B	
		08A	
		08B	
		10A	
10B			

Specifications

Nominal dimension		10	
Maximum working pressure MPa (kgf/cm ²)	Port A, B, P	(Note 1)	31.5 (321)
	Port T		16 (163)
Maximum switching frequency Number of times/min	AC, DC		240
	AC/DC conversion		120
Switching time ms (Note 2)	Solenoid excitation	AC	15 to 25
		DC	70 to 110
		AC/DC conversion	70 to 110
	Solenoid demagnetization	AC	8 to 25
		DC	40 to 50
	AC/DC conversion	(Note 3)	170 to 200
Highest operating temperature °C		50	
Waterproof		IP64	
Mass kg	Single solenoid type	AC	2.9
		AC/DC conversion	3.6
	Double solenoid type	AC	3.6
		AC/DC conversion	5

(Note 1) The maximum working pressure is 25 MPa (255 kgf/cm²) only for spool type "07".

(Note 2) Switching time varies slightly depending on use conditions.

(Note 3) A quick return type, in which switching time at the time of deenergization of the solenoid is equivalent to that of DC solenoid, is also available.

Sub-plate

Valve type	Sub-plate type	Connection diameter	Mass
DE10P	P-DE10R38-0	Rc $\frac{3}{8}$	2.1 kg
	P-DE10G38-0	G $\frac{3}{8}$	
	P-DE10R12-0	Rc $\frac{1}{2}$	
	P-DE10G12-0	G $\frac{1}{2}$	

When you use a sub-plate, please place an order for the above sub-plate type.

For the dimension drawing, refer to page 9 of the appendix.

Accessories

● Mounting bolt

Type	Hexagon socket head cap thread	Quantity	Tightening torque N·m (kgf·cm)
DE10P	M6×35L	4 pcs.	13 ± 1 (133 ± 10)

Solenoid specifications

Solenoid type	Power supply	Symbol	Rated voltage V	Frequency Hz	Working voltage range V	Current value at rated voltage			Energized time	Type of coil insulation
						Holding current A	Starting current A	Electric power W		
Oil immersion type	Alternating current A	A100	100	50	80 to 110	0.90	5.37	—	Continuous rating	H type
				60	90 to 120	0.63	4.57			
				110		0.77	5.03			
		A120	120	50	96 to 132	0.75	4.48			
				60	108 to 144	0.52	3.81			
		A200	200	50	160 to 220	0.45	2.69			
				60	180 to 240	0.31	2.29			
		A240	240	50	192 to 264	0.37	2.24			
				60	216 to 288	0.26	1.91			
	Direct current D	D	D12	12	—	10.8 to 13.2	3.16	—	38	
			D24	24		21.6 to 26.4	1.57			
			D48	48		43.2 to 52.8	0.79			
			D100	100		90 to 110	0.38			
			D110	110		99 to 121	0.34			
			D200	200		180 to 220	0.19			
			D220	220		198 to 242	0.17			
	AC/DC conversion R	R	R100	100	50/60	90 to 110	0.43	—	38	
			R110	110		99 to 121	0.39			
			R200	200		180 to 220	0.21			
R220			220	198 to 242		0.19				

Connection method

- Similar to that of solenoid operated directional valve (DE6)
Refer to the section of the type number index "DE6".

Maximum flow rate

● With AC solenoid DE10P-20***-WA*

Number of positions	Position holding method	Spool type symbol	Hydraulic symbols	Maximum flow rate L/min											
				Flow direction P→A(B)→B(A)→T of oil				Flow direction of oil P→A				Flow direction of oil P→B			
				Working pressure MPa (kgf/cm ²)				Working pressure MPa (kgf/cm ²)				Working pressure MPa (kgf/cm ²)			
				10 (102)	16 (163)	25 (255)	31.5 (321)	10 (102)	16 (163)	25 (255)	31.5 (321)	10 (102)	16 (163)	25 (255)	31.5 (321)
3 positions	2 (Spring center type)	05		100	100	100	100	100 (70)	100 (48)	96 (28)	65 (24)	100 (70)	100 (48)	96 (28)	65 (24)
		06		30	30	30	30	26	21	18	16	30	28	28	28
		07		70	70	70	—	100	100	100	—	100	100	100	—
		08		90	90	90	90	100 (81)	100 (81)	100 (81)	100 (81)	100 (81)	100 (81)	100 (81)	100 (81)
		09		100	100	100	100	100 (80)	100 (65)	85 (35)	62 (28)	100 (80)	100 (65)	85 (35)	62 (28)
		10		80	80	80	80	100 (75)	100 (30)	80 (20)	30 (15)	100 (58)	100 (33)	76 (22)	46 (19)
		12		90	90	90	90	100 (90)	100 (30)	90 (30)	20 (20)	100 (55)	100 (36)	60 (21)	34 (16)
		13		100	100	100	100	60	60	60	60	60	60	60	60
		17		100	100	100	100	100 (75)	100 (25)	80 (30)	20 (25)	100 (62)	100 (40)	84 (21)	48 (16)
		21		80	80	80	80	100 (80)	100 (30)	80 (30)	20 (25)	100 (55)	100 (36)	60 (21)	34 (16)
		22		100	100	100	100	100 (100)	100 (50)	60 (30)	30 (30)	100 (22)	100 (22)	40 (22)	40 (22)
2 positions	2 (Spring offset type)	01		—	—	—	—	26	19	18	16	100 (35)	87 (15)	61 (9)	49 (7)
		02		—	—	—	—	100 (35)	87 (15)	61 (9)	49 (7)	26	19	18	16
		03		100	100	100	100	57	57	57	57	100 (79)	100 (72)	100 (64)	100 (59)
		04		100	100	100	100	34	24	20	19	100 (92)	100 (89)	100 (78)	94 (70)
		25		100	100	100	100	100 (62)	100 (62)	100 (44)	94 (37)	100 (62)	100 (62)	100 (44)	94 (37)
	1 (No spring type with detent)	01		—	—	—	—	50	50	50	40	50	50	50	40
		03		100	100	100	100	40	40	30	28	60	60	40	35
		04		100	100	100	100	40	40	30	28	60	60	40	35

(Note) The relationship between the maximum flow rate and the frequency and voltage in the above table is as shown below.

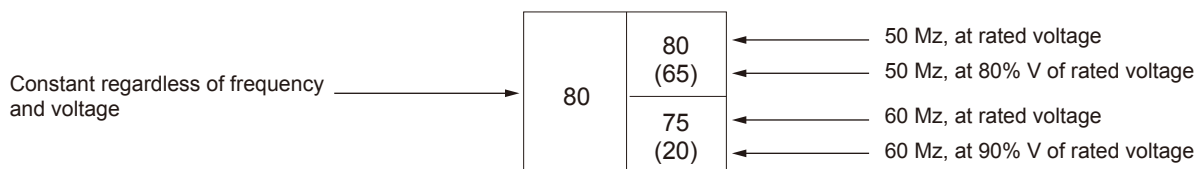

Maximum flow rate

● With DC solenoid DE10P-20-***-WD*

With AC/DC conversion type solenoid DE10P-20-***-WR*

Number of positions	Position holding method	Spool type symbol	Hydraulic symbols	Maximum flow rate L/min												
				Flow direction P→A(B)→B(A)→T 				Flow direction of oil P→A 				Flow direction of oil P→B 				
				Working pressure MPa (kgf/cm²)				Working pressure MPa (kgf/cm²)				Working pressure MPa (kgf/cm²)				
				10 (102)	16 (163)	25 (255)	31.5 (321)	10 (102)	16 (163)	25 (255)	31.5 (321)	10 (102)	16 (163)	25 (255)	31.5 (321)	
3 positions	2 (Spring center type)	05		120	120	120	120	120	120	80	55	120	120	80		
		06		50	50	50	50	35	24	21	20	45	45	45	45	
		07		120	120	120	—	120	120	120	—	120	120	120	—	
		08		120	120	120	120	120	120	120	120	120	120	120	120	
		09		120	120	120	120	100	100	80	65	100	100	80	65	
		10		120	120	120	120	120	120	84	64	120	120	84	64	
		12		120	120	120	65	120	120	62	51	120	120	62	51	
		13		120	120	120	120	100	100	100	100	100	100	100	100	
		17		120	120	120	120	120	120	120	62	49	120	120	62	49
		21		120	120	120	65	120	120	112	60	120	120	112	60	
		22		120	120	120	45	120	120	67	35	120	120	67	35	
2 positions	2 (Spring offset type)	01		—	—	—	—	53	33	24	23	120	120	62	47	
		02		—	—	—	—	120	120	62	47	53	53	33	24	
		03		120	120	120	120	77	77	77	77	120	120	120	120	
		04		110	110	110	110	68	47	38	38	120	120	114	75	
		25		110	110	110	110	120	120	114	75	68	68	47	38	
	1 (No spring type with detent)	01		—	—	—	—	60	60	40	35	60	60	40	35	
		03		120	120	120	120	45	37	30	28	60	60	40	35	
		04		120	120	120	120	45	37	30	28	60	60	40	35	

(Note) The relationship between the maximum flow rate and the frequency and voltage in the above table is as shown below.

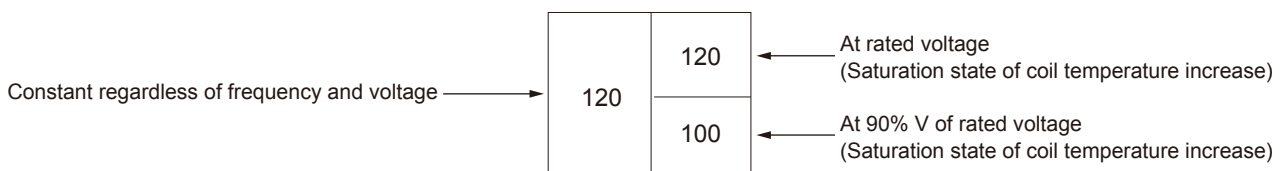

Maximum flow rate

● When switching the valve to neutral state with spool type 06, 07 and 08 reaching the stroke end

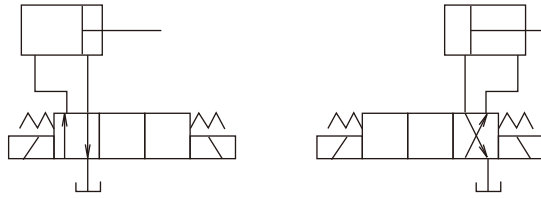

Number of positions	Position holding method	Spool type symbol	Hydraulic symbols	Solenoid	Maximum flow rate L/min			
					Working pressure MPa (kgf/cm ²)			
					10 (102)	16 (163)	25 (255)	31.5 (321)
3 positions	2 (Spring center type)	06		AC	26	21	18	16
				DC, AC/DC conversion	35	24	21	20
		07		AC	84	52	52	—
				DC, AC/DC conversion	68	65	61	—
		08		AC	100	100	100	100
				DC, AC/DC conversion	120	120	120	120

Pressure drop characteristics (viscosity 36 mm²/s (cSt))

DE10

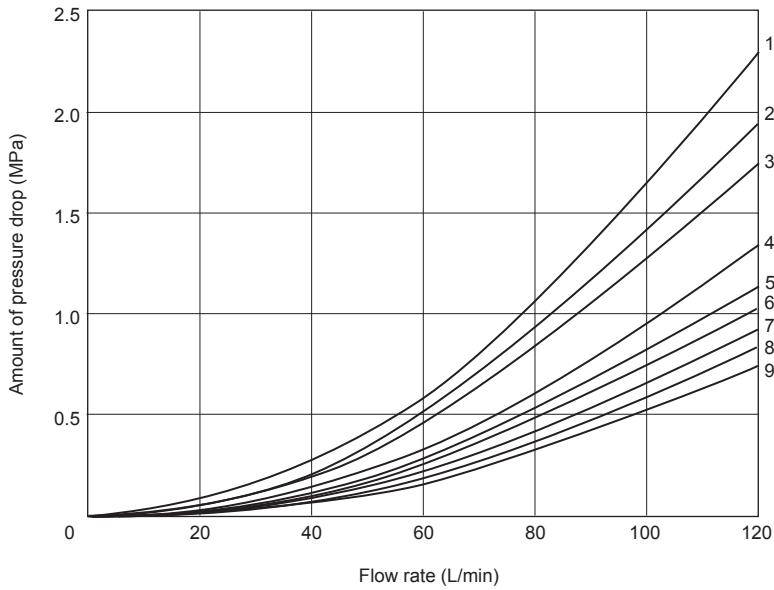

Spool holding method	Flow direction				
	P→A	B→T	P→B	A→T	P→T
205	7	7	7	7	-
206	9	7	7	9	1
207	6	5	6	5	1
208	9	9	9	9	5
209	9	7	7	7	-
210	7	8	7	8	-
212	7	7	7	8	-
213	9	7	9	7	-
217	7	7	7	7	-
221	7	8	7	7	-
222	7	7	7	7	-
201	6	-	5	-	-
202	5	-	6	-	-
203	3	2	9	9	-
204	2	1	7	7	-
225	7	7	2	1	-
101	6	-	6	-	-
103	6	4	7	7	-
104	4	3	6	6	-

Option

The following options are available in addition to the standard items.

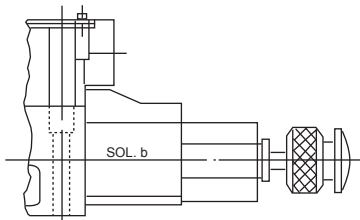

<With push button lock>

At the time of adjustment, the valve can be held at the switched position even if the solenoid in an emergency is not energized.

When placing an order, add a special type, -07, at the end of the type.

Precautions in use

- **Mounting posture**
When using the valve of the no spring detent type without excitation, mount the solenoid horizontally so that the detent effect is securely obtained. For the valve of other type, there is no limitation of mounting posture.
- **Switching of solenoid**
Be sure to deenergize one solenoid before energizing the other solenoid.
- **Tank port**
Do not connect the tank port to a conduit where surge pressure is generated. Be sure to immerse the end of the tank line piping into oil.
- **Manual pin operating force**
Be careful that the operation of the manual pin is difficult if the back pressure of the tank line becomes high.

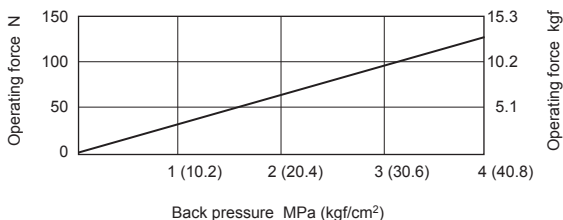

Dimension drawing

● DE10P (Integrated terminal box type)

- With AC solenoid
- Spring center type
- No spring detent type

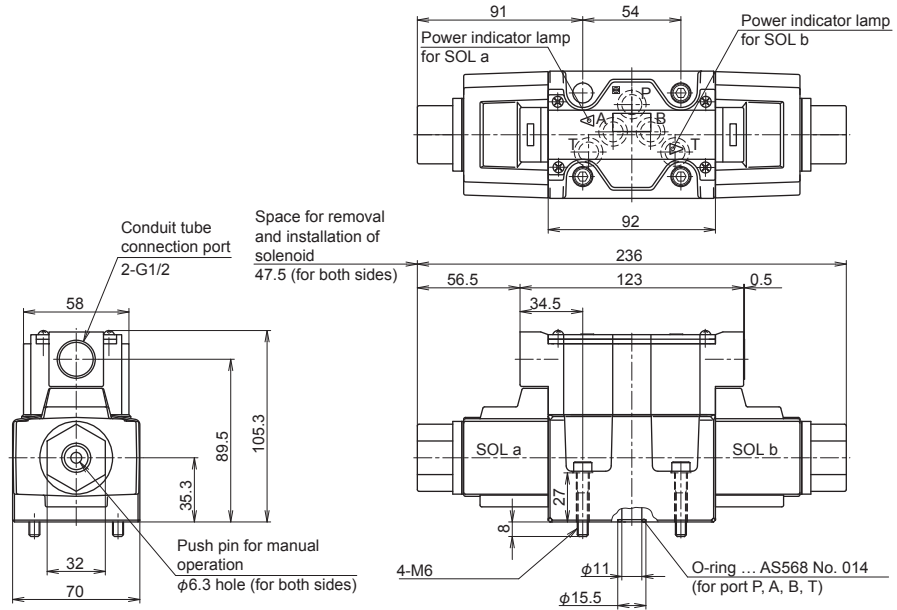

Spring offset type

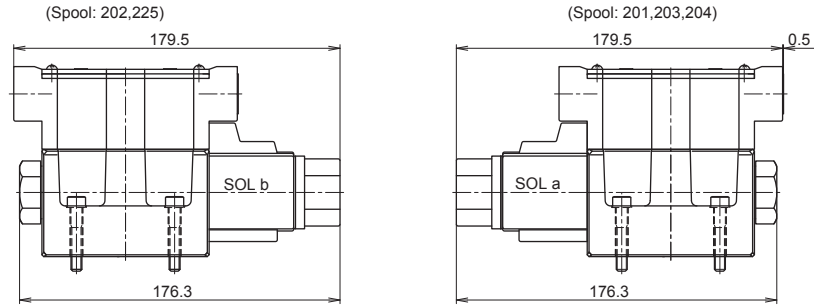

- With DC solenoid
 - With AC/DC conversion type solenoid
- (Note) For other dimensions, refer to "with AC solenoid".

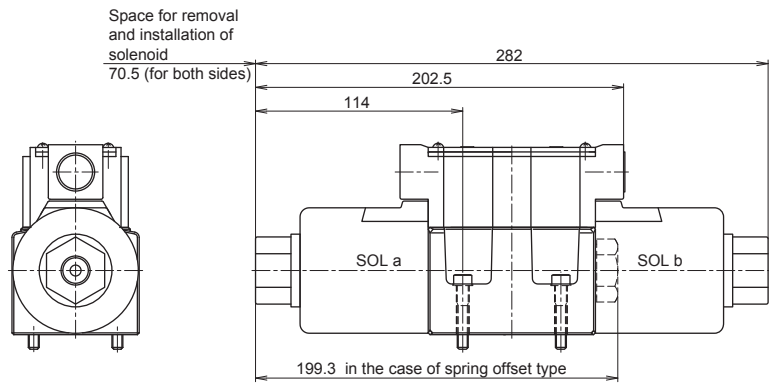

Mounting surface accuracy

Flatness : $\square 0.01/\square 100$

Surface roughness : $\sqrt{1.6}$

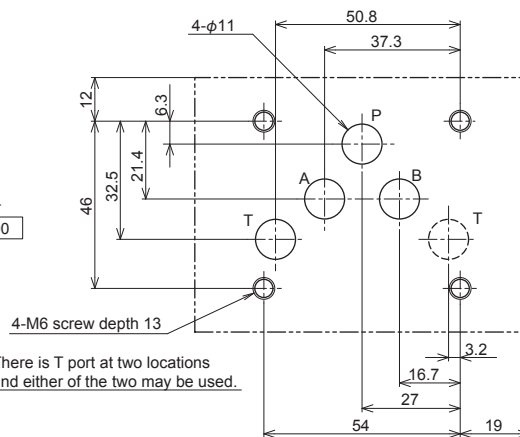

There is T port at two locations and either of the two may be used.

Machining dimension of manifold

● **DE10P** (DIN connector type, DIN large connector type, DIN large connector type with power indicator lamp)

- With AC solenoid
- Spring center type
- No spring detent type

The position can be changed by loosening the lock nut ★. After changing the position, be sure to tighten the lock nut.

The direction can be freely changed for every 90 degrees.

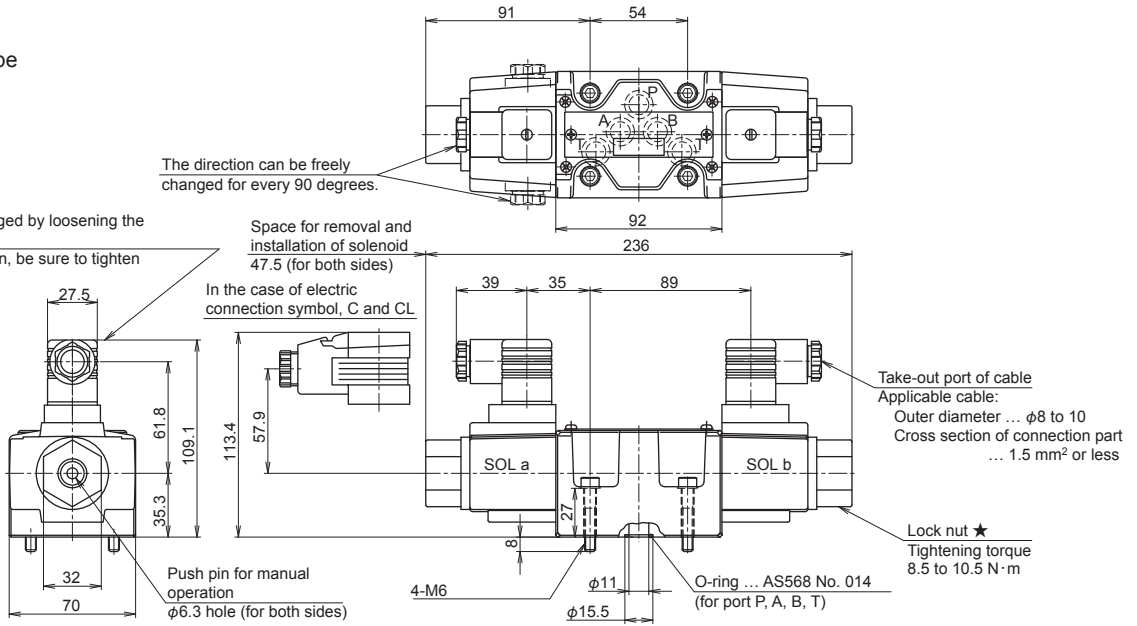

Spring offset type

(Spool: 202,225)

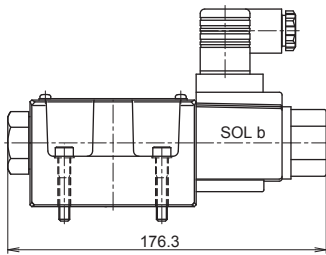

(Spool: 201,203,204)

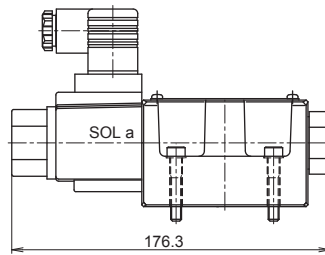

- With DC solenoid
- With AC/DC conversion type solenoid
- (Note) For other dimensions, refer to "with AC solenoid".

Space for removal and installation of solenoid 70.5 (for both sides)

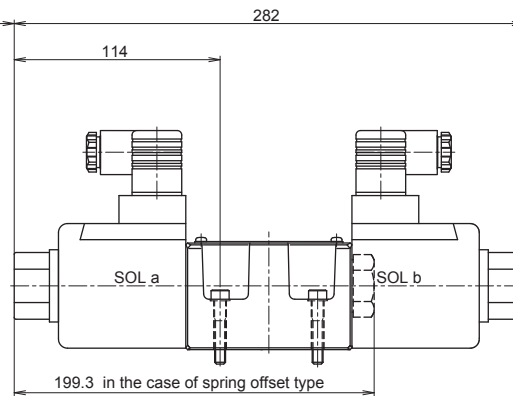
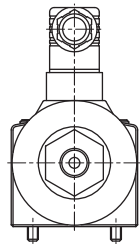

Mounting surface accuracy
 Flatness : $\nabla 0.01/100$
 Surface roughness : 1.6

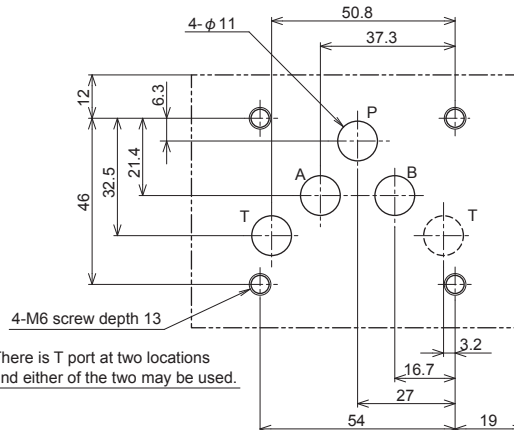

Machining dimension of manifold

Solenoid controlled pilot operated directional valve (1) DEH16 to 32

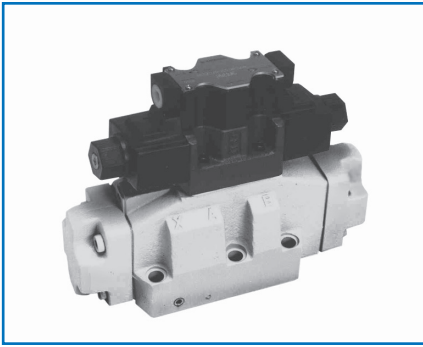

3 position valve spring center type

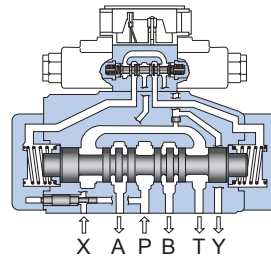

3 position valve hydraulic center type

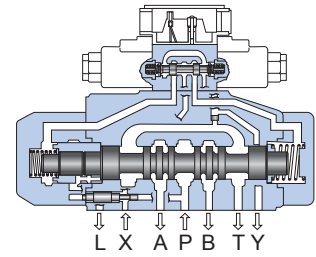

Overview

This solenoid controlled pilot operated directional valve is used for operating the solenoid operated directional valve and for controlling start and stop, and movement direction of the hydraulic system with hydraulic pilot signals.

Features

1. The improvement of internal coring shape and spool shape of the casing has substantially reduced the flow resistance.
2. For return to neutral of the main valve, the spring center type and pressure-centred type are prepared as standard items.
3. A stroke limiter for adjusting spool stroke of the main valve can be installed.
4. The selection between the internal pilot and external pilot can be made only by changing the assembly direction of the plug for selection.
5. The maximum working pressure is 34.3 MPa (350 kgf/cm²).

Type indication

DEH16

DEH16P - 31 - 205 - 2 W A 100 AL P08 - ET S2 10 -

Solenoid controlled pilot operated directional valve

Nominal dimension
16

Connection method
P = Gasket connection type

Series number
Without choke valve = 30
With choke valve = 31

Position holding method (main valve)
2 = 2 position, spring offset type
3 position, spring center type
3 = 2 position, hydraulic offset type
3 position, hydraulic center type

Spool type
* Refer to "Spool type symbols".

Position holding method (solenoid valve)
1 = 2 position, no spring type (with detent)
2 = 2 position, spring offset type
or 3 position, spring center type

Solenoid type
W = Wet type (with standard emergency manual operation)

Input power supply
A = Alternating current
D = Direct current
R = AC/DC conversion

Input voltage

Direct current D	Alternating current A	AC/DC conversion R
12 : 12V 24 : 24V 48 : 48V	100 : 100V-50/60Hz 110V-60Hz	100 : 100V-50/60Hz 200 : 200V-50/60Hz
	120 : 110V-50Hz 120V-50/60Hz	
	200 : 200V-50/60Hz 220V-60Hz	
	240 : 220V-50Hz 240V-50/60Hz	

* For other power supply voltage, please contact us.

Type of hydraulic oil

No symbol = Mineral based hydraulic oil
V = Phosphate ester based hydraulic oil
W = Fatty ester based hydraulic oil
Water-glycol based hydraulic oil

Accessory parts of cover part provided or not

No symbol = No accessory parts
10 = with stroke limiter
11 = with stroke limiter on port A side
12 = with stroke limiter on port B side

Pilot pressure reducing valve provided or not

No symbol = without pressure reducing valve
R = with pressure reducing valve

Choke valve provided or not

No symbol = without choke valve
S1 = with meter-in choke valve
S2 = with meter-out choke valve

Pilot and drain type

No symbol = external pilot, external drain
E = internal pilot, external drain
ET = internal pilot, internal drain
T = external pilot, internal drain

P port restriction of solenoid valve

No symbol = No restriction
P08 = Restriction contraction diameter ϕ 0.8 mm
P10 = Restriction contraction diameter ϕ 1.0 mm
P12 = Restriction contraction diameter ϕ 1.2 mm
P15 = Restriction contraction diameter ϕ 1.5 mm
P20 = Restriction contraction diameter ϕ 2.0 mm
P25 = Restriction contraction diameter ϕ 2.5 mm
P30 = Restriction contraction diameter ϕ 3.0 mm
P40 = Restriction contraction diameter ϕ 4.0 mm

Electric connection symbol

* For details, refer to the section of "Solenoid operated directional valve".

Symbol	Pilot valve type
	DE6
AL	Integrated terminal box with lamp
B	With DIN connector
C	With DIN large connector
CL	With DIN large connector with lamp

Type indication

DEH22,32

DEH 22 P - 21 - 305 - 2WD 24 AL P08 - S2 R -

Solenoid controlled pilot operated directional valve

Nominal dimension
22, 32

Connection method
P = Gasket connection type

Series number
Without choke valve = 20
With choke valve = 21

Position holding method (main valve)
2 = 2 position, spring offset type
3 position, spring center type
3 = 2 position, hydraulic offset type
3 position, hydraulic center type

Spool type
* Refer to "Spool type symbols".

Position holding method (solenoid valve)
1 = 2 position, no spring type (with detent)
2 = 2 position, spring offset type
or 3 position, spring center type

Solenoid type
W = Wet type (with standard emergency manual operation)
(For the explosion proof type, please contact us.)

Input power supply
A = Alternating current
D = Direct current
R = AC/DC conversion

Input voltage

Direct current D	Alternating current A	AC/DC conversion R
12 : 12V 24 : 24V 48 : 48V	100 : 100V-50/60Hz 110V-60Hz	100 : 100V-50/60Hz 200 : 200V-50/60Hz
	120 : 110V-50Hz 120V-50/60Hz	
	200 : 200V-50/60Hz 220V-60Hz	
	240 : 220V-50Hz 240V-50/60Hz	

* For other power supply voltage, please contact us.

Type of hydraulic oil

No symbol = Mineral based hydraulic oil
V = Phosphate ester based hydraulic oil
W = Fatty ester based hydraulic oil
Water-glycol based hydraulic oil

Accessory parts of cover part provided or not

No symbol = No accessory parts
10 = with stroke limiter
11 = with stroke limiter on port A side
12 = with stroke limiter on port B side

Pilot pressure reducing valve provided or not

No symbol = without pressure reducing valve
R = with pressure reducing valve

Choke valve provided or not

No symbol = without choke valve
S1 = with meter-in choke valve
S2 = with meter-out choke valve

Pilot and drain type

No symbol = external pilot, external drain
E = internal pilot, external drain
ET = internal pilot, internal drain
T = external pilot, internal drain

P port restriction of solenoid valve

No symbol = No restriction
P08 = Restriction contraction diameter ϕ 0.8 mm
P10 = Restriction contraction diameter ϕ 1.0 mm
P12 = Restriction contraction diameter ϕ 1.2 mm
P15 = Restriction contraction diameter ϕ 1.5 mm
P20 = Restriction contraction diameter ϕ 2.0 mm
P25 = Restriction contraction diameter ϕ 2.5 mm
P30 = Restriction contraction diameter ϕ 3.0 mm
P40 = Restriction contraction diameter ϕ 4.0 mm

Electric connection symbol

* For details, refer to the section of "Solenoid operated directional valve".

Symbol	Pilot valve type
	DE10
AL	Integrated terminal box with lamp
B	With DIN connector
C	With DIN large connector
CL	With DIN large connector with lamp

Spool type symbol

Valve type	Spool type	Hydraulic symbols	Transient state	Spool holding method	Detailed hydraulic symbols (Example: External pilot and external drain type)	Simplified hydraulic symbols (Example: External pilot and external drain type)
2 position valve				Spring offset type		
	03			Hydraulic offset type		
	04					
	11					
	26					
				No spring type with detent		
3 position valve				Spring center type		
	05					
	06					
	07					
	08					
	10					
	12					
	Hydraulic center type	13				
		17				
		18				
		19				
		20				
		21				
		22				
23						

Specifications

Nominal dimension					16	22	32								
Maximum working pressure MPa (kgf/cm ²)	(Note 1) Port P, A, B				34.3 (350)										
	Port T	External drain			24.5 (250)										
		Internal drain	2 position valve, 3 position valve spring (Note 2) 3 position valve hydraulic center type		Oil immersion type solenoid	15.7 (160)									
Highest pilot pressure MPa (kgf/cm ²) (Note 3)					24.5 (250)										
Lowest pilot pressure MPa (kgf/cm ²) (Note 5)	3 position valve				0.78 (8.0)										
	2 position valve spring offset type				0.98 (10.0)										
	2 position valve hydraulic offset type				0.49 (5.0)										
Stroke volume of pilot part cm ³	2 position valve				8.9	19.3	70.7								
	3 position valve spring center type				4.45	9.65	35.5								
	3 position valve pressure center type	Neutral → Position "a" (Solenoid "a" energized)			2.30	5.0	17.25								
		Neutral → Position "b" (Solenoid "b" energized)			4.45	9.65	35.35								
		Position "a" → Neutral			2.15	4.65	18.1								
		Position "b" → Neutral			2.30	4.65	17.25								
Opening area at spool neutral position (with spool 10 as 100%)				Spool 17, 22		16%									
				Spool 23		3%									
Switching time ms (AC solenoid) (Note 4)	Pilot pressure MPa (kgf/cm ²)				5(50)	15(150)	25(250)	5(50)	15(150)	25(250)	5(50)	15(150)	25(250)		
	Neutral → Switching position	2 position valve			35	30	25	80	60	45	105	85	75		
		3 position valve spring center type			30	25	20	40	30	25	60	45	35		
		3 position valve pressure center type	Solenoid "a" → energized			20	20	<20	35	30	<25	55	40	35	
	Solenoid "b" → energized			30	25	20	40	35	25	65	50	45			
	Switching position → Neutral	2 position valve			35	30	25	80	60	45	105	85	75		
		3 position valve spring center type			40			60			95				
		3 position valve pressure center type	Solenoid "a" → deenergized			30	25	20	35	30	25	65	60	60	
Solenoid "b" → deenergized			40	35	25	30	30	25	70	60	60				
Pilot flow rate L/min				27			46			70					
Mass kg				Single solenoid type			8.3			16.0			48.5		
				Double solenoid type			8.6			17.4			49.9		

(Note 1) If the valve is used with the internal pilot, the maximum working pressure of port P is 24.5 MPa (250 kgf/cm²).

(Note 2) If you wish to use the 3 position valve hydraulic center type with the internal drain, please contact us.

(Note 3) In the case of 3 position valve hydraulic center type with meter-out choke valve, the highest pilot pressure is 12.3 MPa (125 kgf/cm²).

(Note 4) Switching time of DC solenoid is obtained by adding the following numerical values to the numerical values in the above table, respectively.

- Nominal dimension 16: 20 ms • Nominal dimension 22 and 32 : 60 ms

(Note 5) If you wish to use the P-T connection spool type with the internal pilot when neutral, please contact us.

Maximum flow rate

Nominal dimension	Spool type	Maximum flow rate L/min					
		Working pressure MPa (kgf/cm ²)					
		7 (70)	14 (140)	20.6 (210)	27.4 (280)	34.3 (350)	
16	(A) 05, 10, 12, 13, 17, 18, 21 22, 23, 03, 04, 11, 26	*	240	240	205	180	170
	06		200	145	115	100	90
	07, 08, 19, 20		220	160	130	110	100
22	(A) 05, 10, 12, 13, 17, 18, 21 22, 23, 03, 04, 11, 26	*	450	450	370	320	300
	06, 07, 08, 19, 20		360	250	210	180	160
32	(A) 05, 10, 12, 13, 17, 18, 21 22, 23, 03, 04, 11, 26	*	1100	1050	860	750	680
	06, 07, 08, 19, 20		820	630	510	450	400

(Note) · The above table shows numerical values in the case of the lowest pilot pressure.

· The maximum flow rate in the case of the 2 position valve hydraulic offset type and 3 position valve hydraulic center type is the flow rate of stage (A) regardless of the spool type, and is the flow rate marked with * regardless of the spool type and pressure if the pilot pressure is 1.5 MPa (15 kgf/cm²) or higher.

Pressure drop characteristics (viscosity 36 mm²/s (cSt))

DEH16

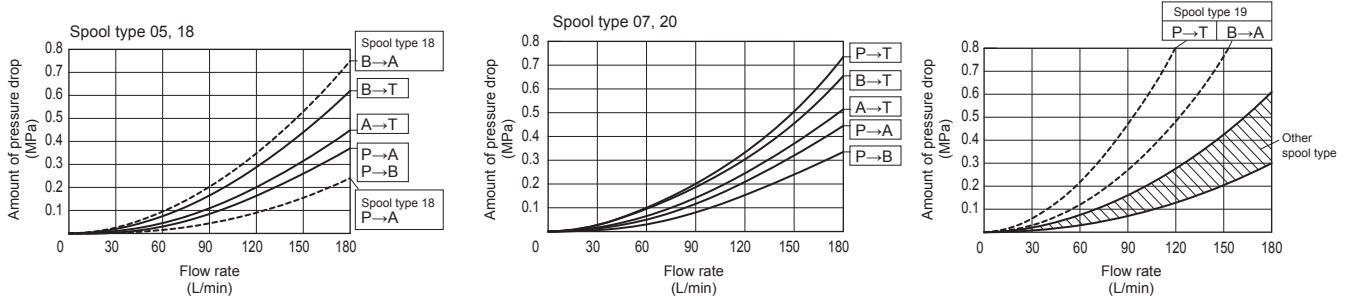

DEH22

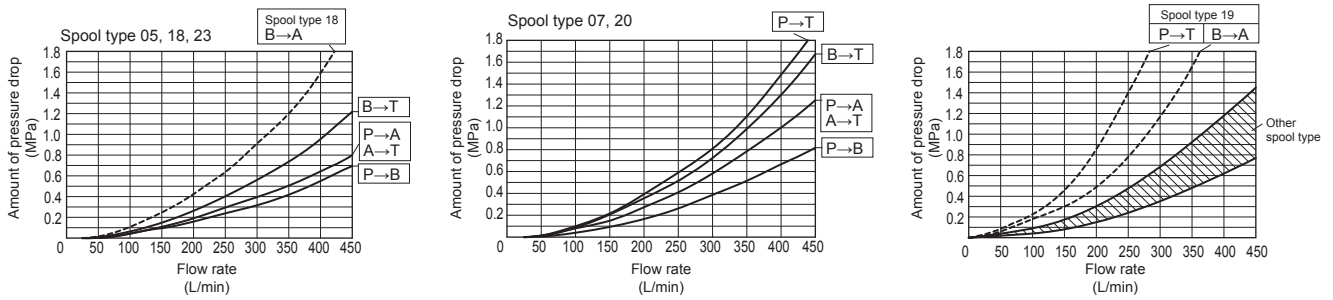

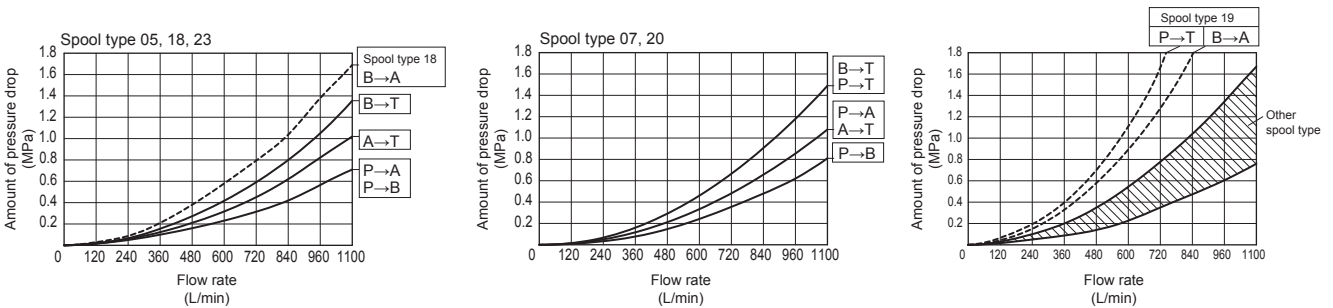

DEH32



Pilot valve

Pilot valve type

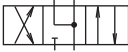
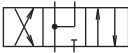
The pilot valve uses the following solenoid operated directional valve.

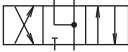
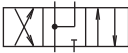
Main valve		Pilot valve		
Nominal dimension	Type	Type	Spool type	Hydraulic symbols
16	2 position valve spring offset type 2 position valve hydraulic offset type	DE 6	04	Spool type 04  Spool type 10  Spool type 13 
	3 position valve spring center type		10	
	3 position valve hydraulic center type		13	
22 32	2 position valve spring offset type 2 position valve hydraulic offset type	DE10	04	Spool type 04  Spool type 10  Spool type 13 
	3 position valve spring center type		10	
	3 position valve hydraulic center type		13	

* For the pilot valve specifications, refer to the section of the type number index "DE6" and "DE10".

Sub-plate

Valve type	Sub-plate type	Connection diameter	Mass
DEH16	P-DEH16R34-0	Rc $\frac{3}{4}$	7.0kg
	P-DEH16G34-0	G $\frac{3}{4}$	
	P-DEH16R1-0	Rc 1	14.5kg
	P-DEH16G1-0	G 1	
DEH22	P-DEH22R1-0	Rc 1	11kg
	P-DEH22G1-0	G 1	
	P-DEH22R54-0	Rc $1\frac{1}{4}$	24kg
	P-DEH22G54-0	G $1\frac{1}{4}$	
	P-DEH22R32-0	Rc $1\frac{1}{2}$	
	P-DEH22G32-0	G $1\frac{1}{2}$	
DEH32	P-DEH32R32-0	Rc $1\frac{1}{2}$	19kg
	P-DEH32G32-0	G $1\frac{1}{2}$	

When you use a sub-plate, please place an order for the above sub-plate type.
For the dimension drawing, refer to pages 9,10 and 11 of the appendix.

Choke valve for adjusting stroke speed

- Handling method When the adjust thread is turned clockwise, switching time of the spool becomes slow and when it is turned counterclockwise, switching time becomes fast.
When meter-in is changed to meter-out, the choke valve needs to be replaced.

Pilot valve

Choke valve

Main valve

In the case of meter-in (choke valve: S-2TC*-20-E1)

Pilot valve side	Main valve side
Main valve side	Pilot valve side

In the case of meter-out (choke valve: S-2TC*-20-F1)

Pilot valve side	Main valve side
Main valve side	Pilot valve side

Nominal dimension	Choke valve type
16	S-2TC 6-20- $\frac{E}{F}$ 1
22, 32	S-2TC10-20- $\frac{E}{F}$ 1

Accessories

Mounting bolt

Type	Hexagon socket head cap thread	Quantity	Tightening torque N·m (kgf·cm)
DEH16	M6×55L	2 pcs.	11.8± 1.7 (120± 18)
	M10×60L	4 pcs.	56.8± 8.5 (580± 87)
DEH22	M12×60L	6 pcs.	98.0±14.7 (1000±150)
DEH32	M20×80L	6 pcs.	431.2±64.6 (4400±660)

Dimension drawing

DEH16

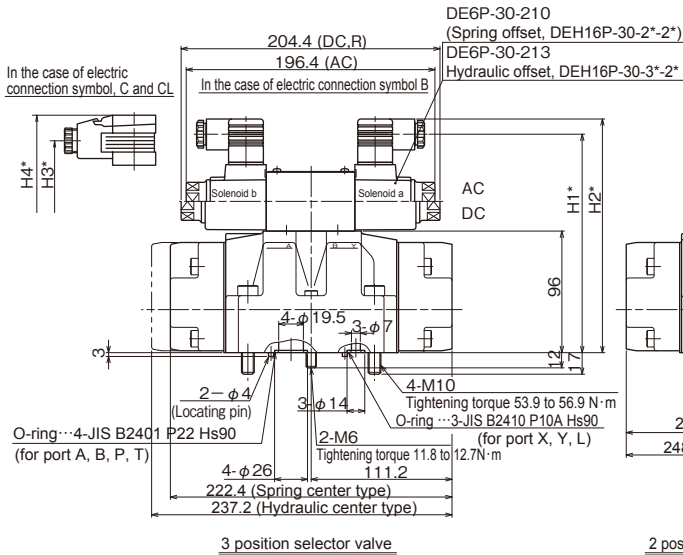
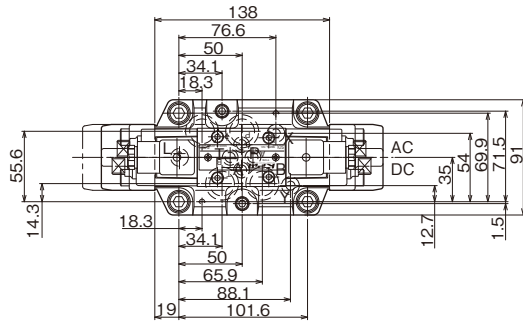

(Note. Port L is not used in the case of the spring center type.
Use port L with tank pressure in the case of the hydraulic center type.)

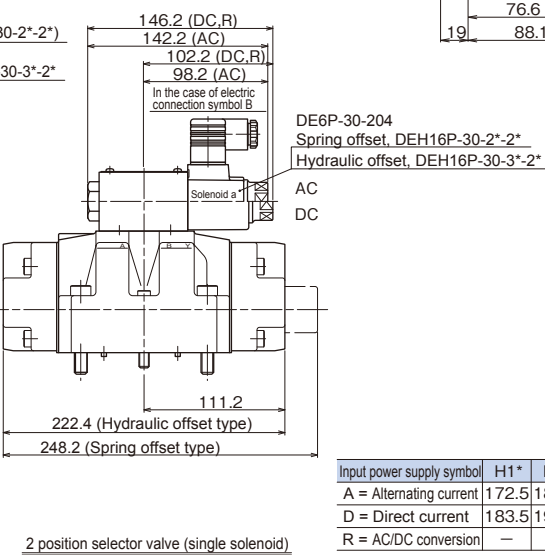
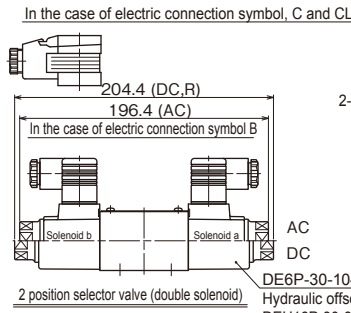

(Note. Port L is not used.)

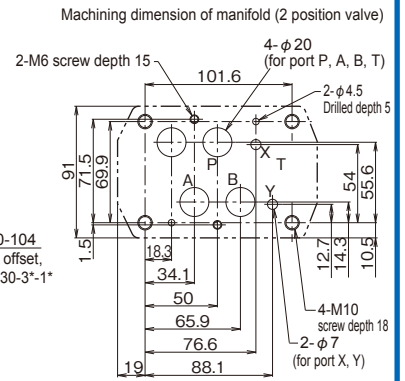

Input power supply symbol	H1*	H2*	H3*	H4*
A = Alternating current	172.5	184.5	165.6	187.5
D = Direct current	183.5	195.5	176.7	198.5
R = AC/DC conversion	-	-	176.7	198.5

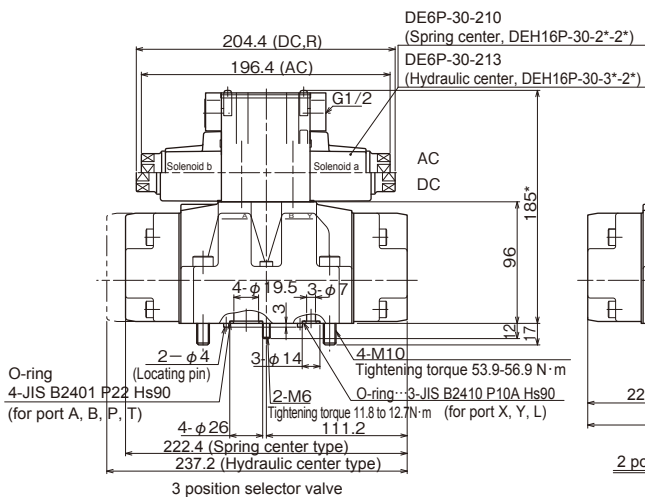
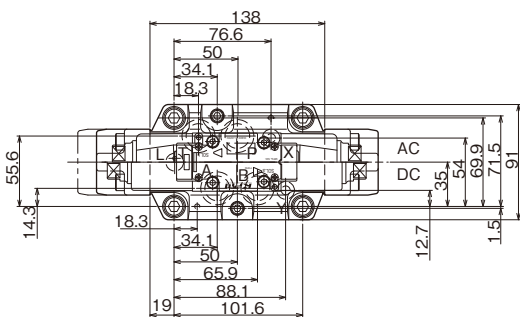

(Note. Port L is not used in the case of the spring center type.
Use port L with tank pressure in the case of the hydraulic center type.)

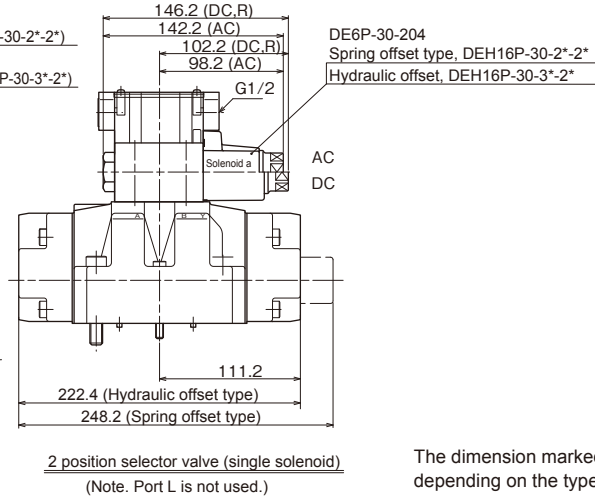
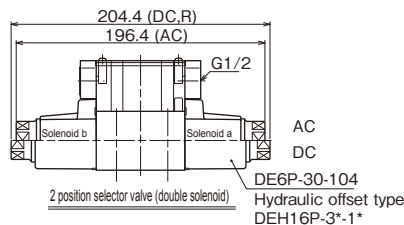

(Note. Port L is not used.)

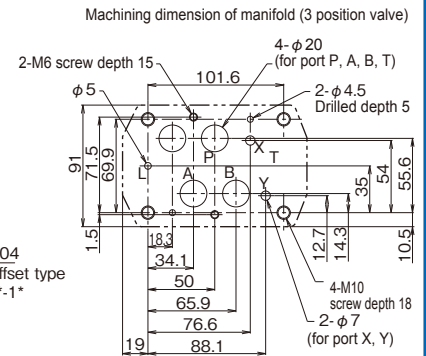

The dimension marked with * differs depending on the type.
With choke valve (S1, S2): +40 mm
With pressure reducing valve (R): +40 mm

DEH22 (2 position valve)
Integrated terminal box type

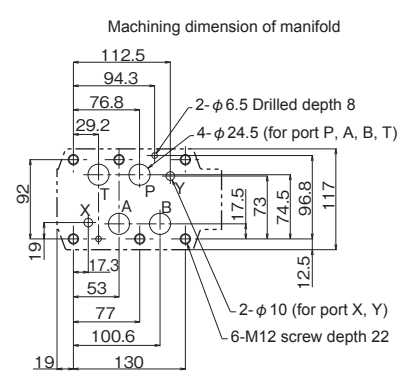
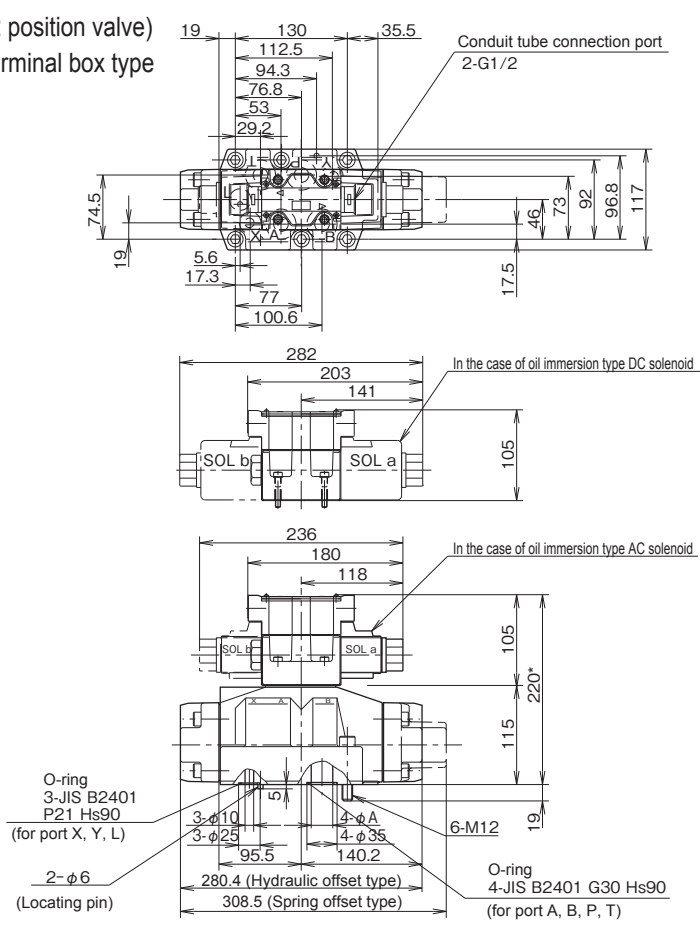

(Note) Port L is not used.

The dimension marked with * differs depending on the type.
 With choke valve (S1, S2): +55 mm
 With pressure reducing valve (R): +50 mm

Dimension	φA
Port P	24
Port A, B	24.5
Port T	25

DEH22 (3 position valve)
Integrated terminal box type

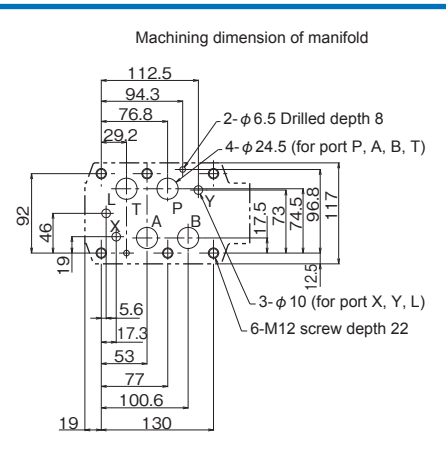
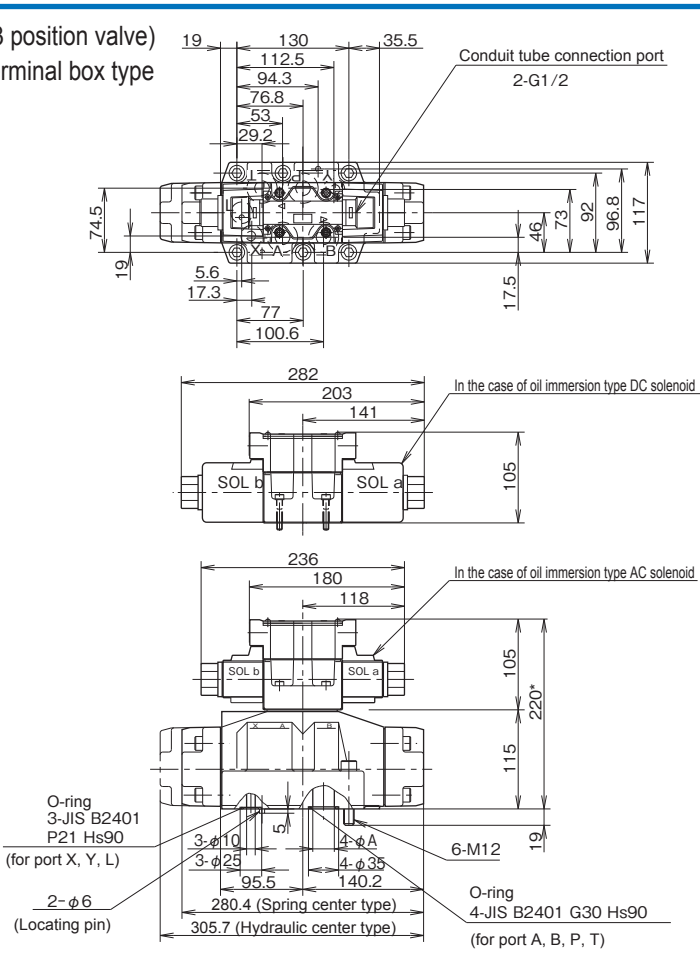

(Note) Port L is not used in the case of the spring center type.
 Use port L with tank pressure in the case of the hydraulic center type.

The dimension marked with * differs depending on the type.
 With choke valve (S1, S2): +55 mm
 With pressure reducing valve (R): +50 mm

Dimension	φA
Port P	24
Port A, B	24.5
Port T	25

DEH22 (2 position valve)

DIN connector type

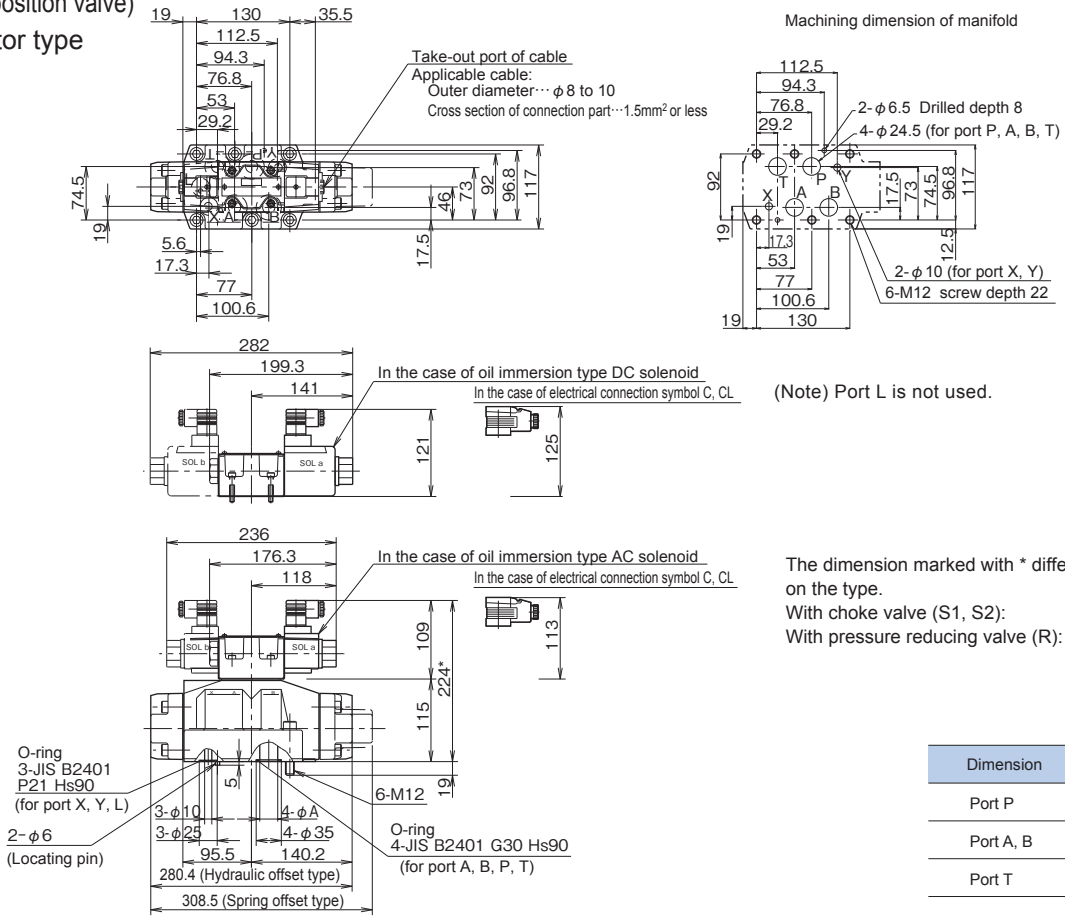

DEH22 (3 position valve)

DIN connector type

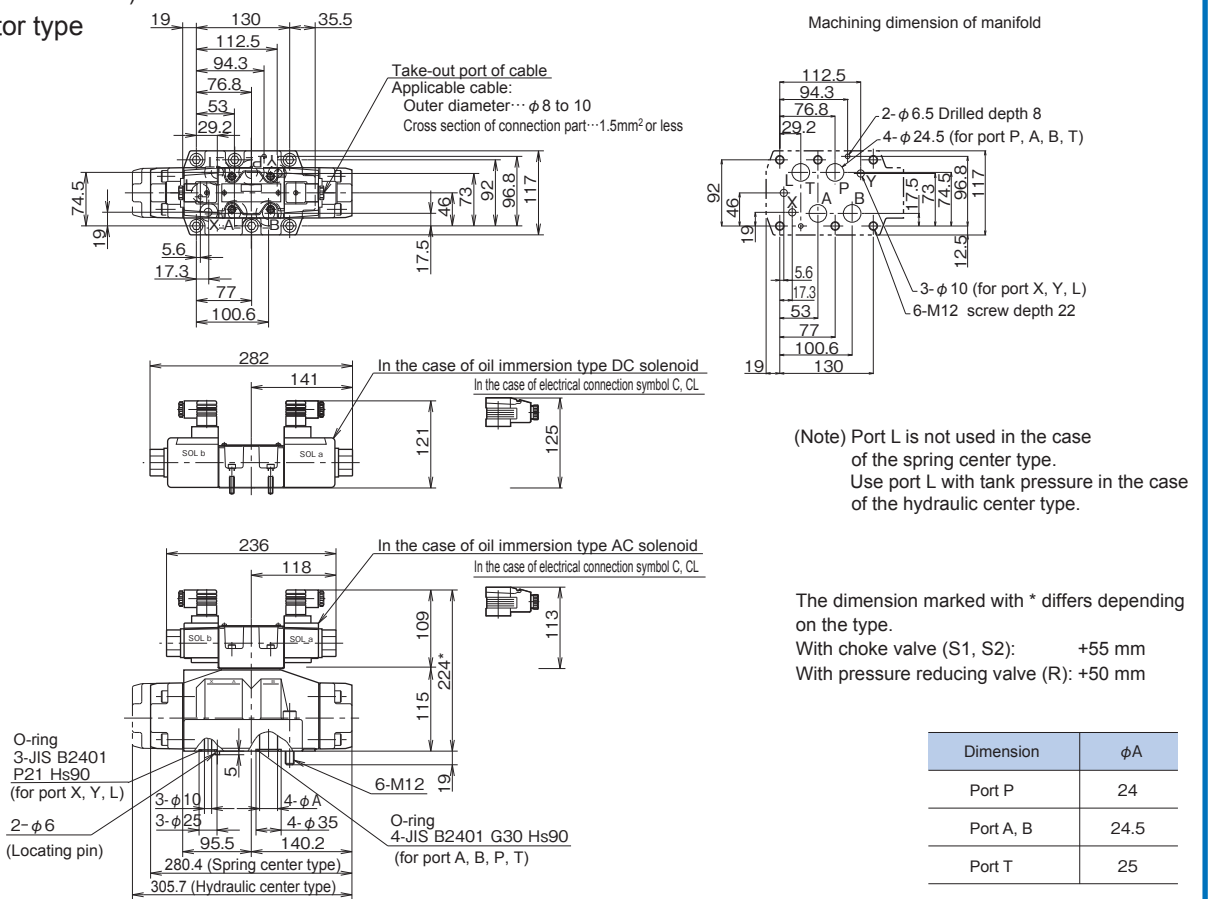

DEH32 (2 position valve)
Integrated terminal box type

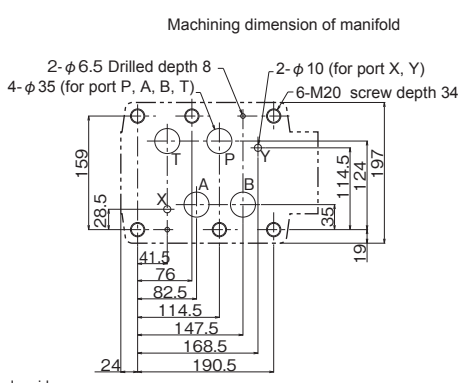
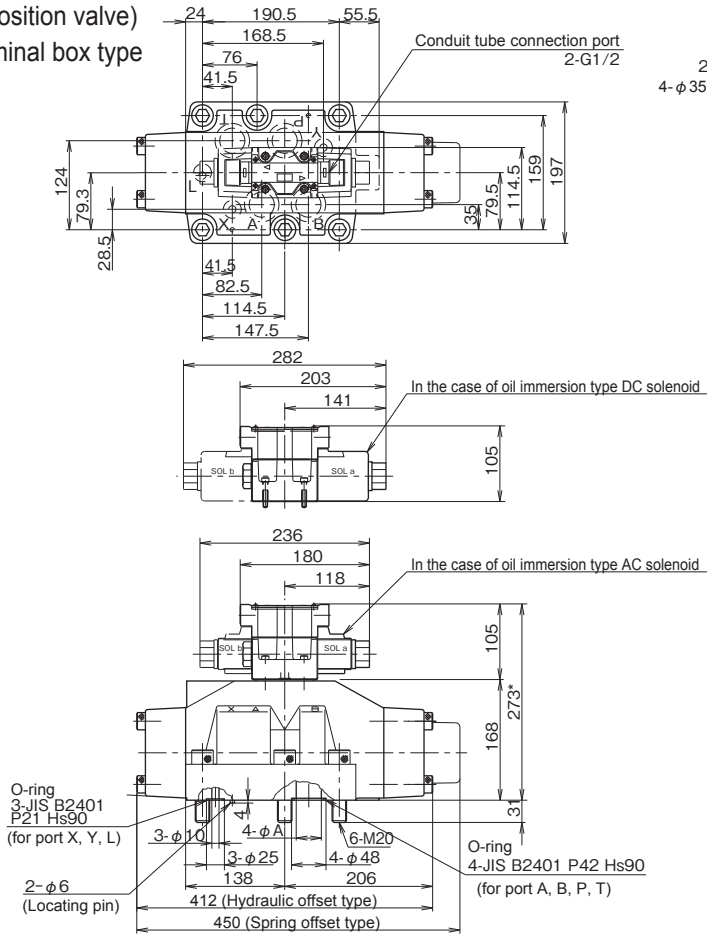

(Note) Port L is not used.

The dimension marked with * differs depending on the type.
With choke valve (S1, S2): +55 mm
With pressure reducing valve (R): +50 mm

Dimension	φA
Port P	38
Port A, B, T	35

DEH32 (3 position valve)
Integrated terminal box type

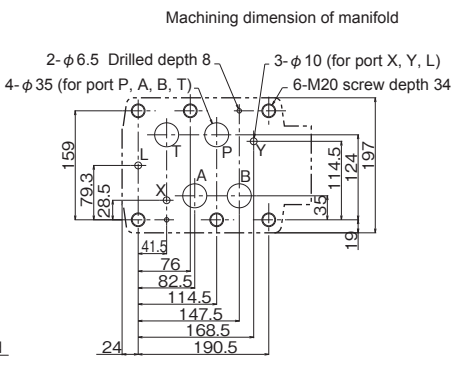
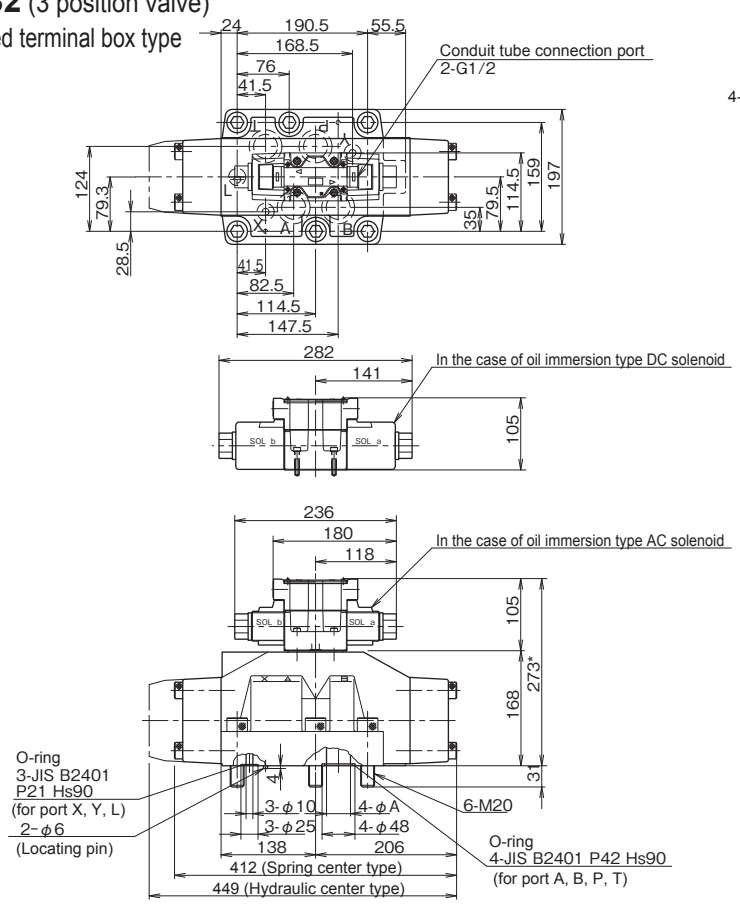

(Note) Port L is not used in the case of the spring center type.
Use port L with tank pressure in the case of the hydraulic center type.

The dimension marked with * differs depending on the type.
With choke valve (S1, S2): +55 mm
With pressure reducing valve (R): +50 mm

Dimension	φA
Port P	38
Port A, B, T	35

DEH32 (2 position valve)
DIN connector type

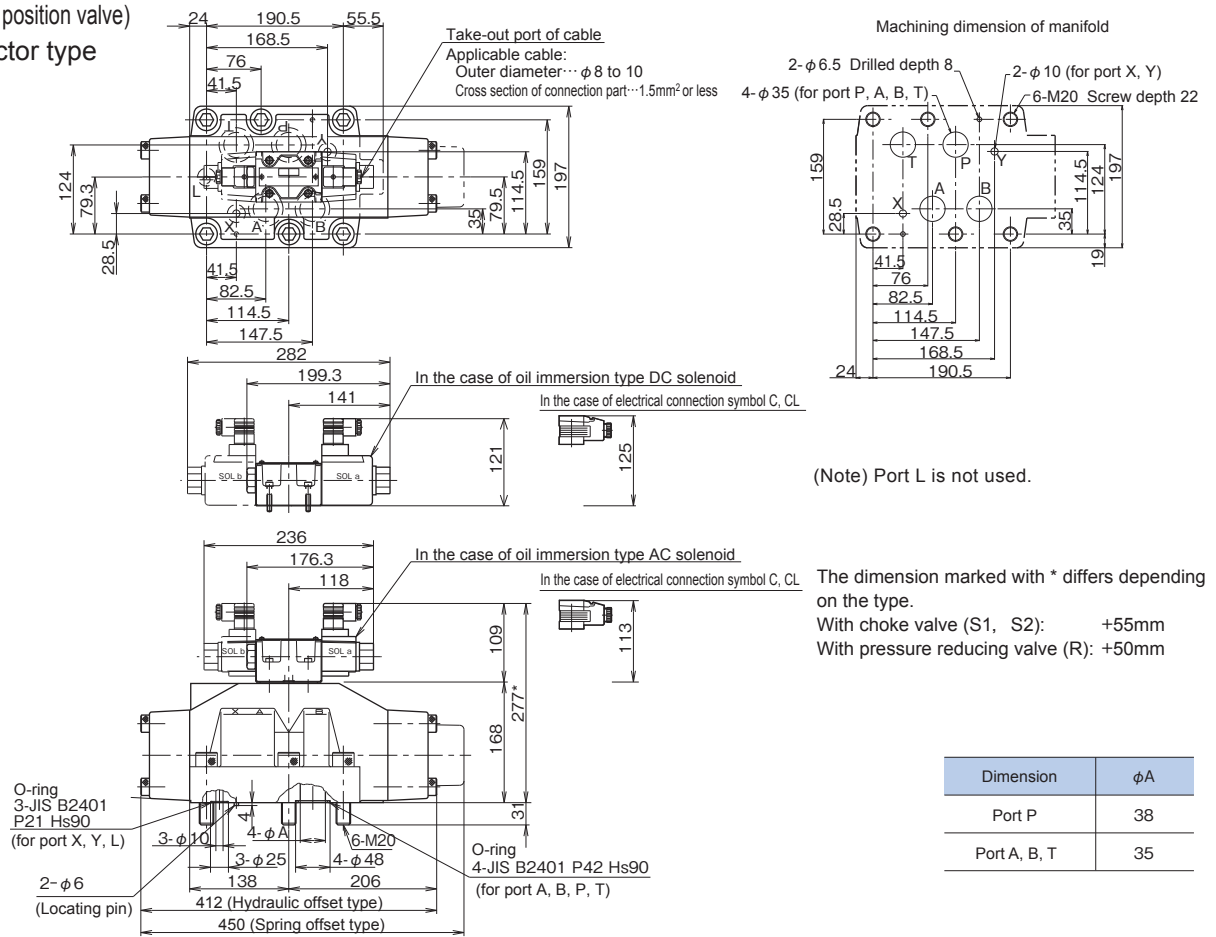

DEH32 (3 position valve)
DIN connector type

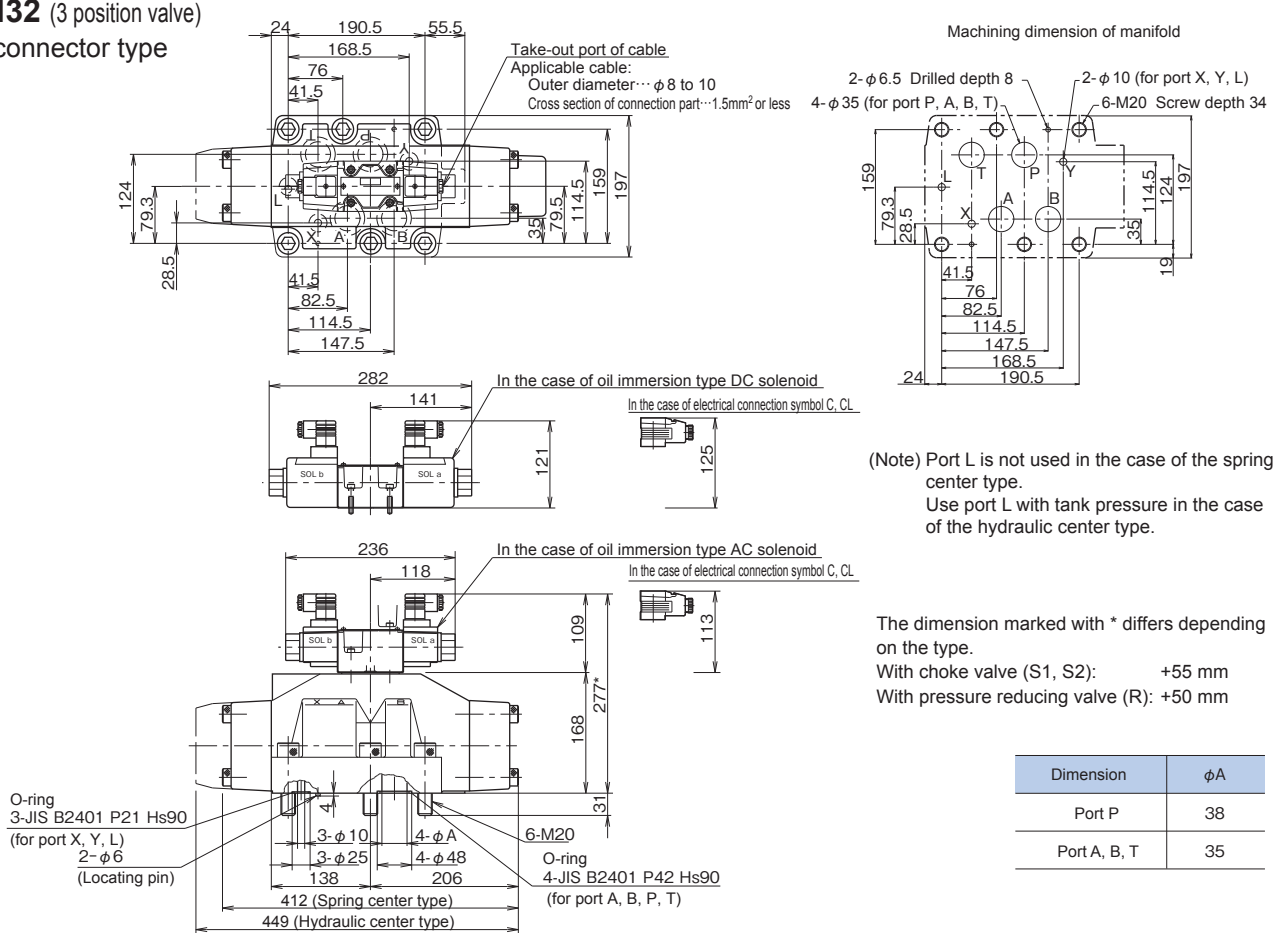

Solenoid controlled pilot operated directional valve (2) DEH52

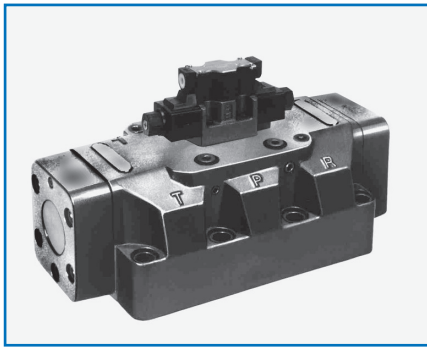

3 position valve gasket connection type

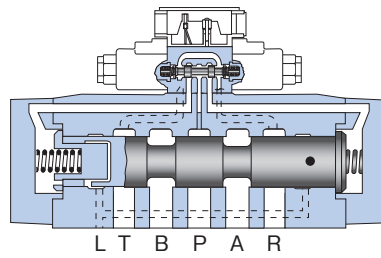

3 position valve flange connection type

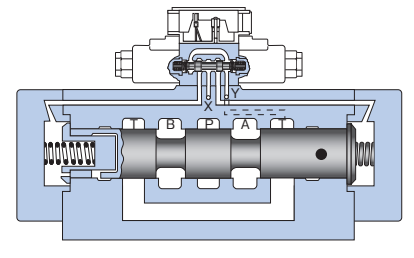

Overview

This solenoid controlled pilot operated directional valve is used for operating the solenoid operated directional valve and for controlling start and stop, and movement direction of the hydraulic system with hydraulic pilot signals.

Features

1. The improvement of internal coring shape and spool shape of the casing has substantially reduced the flow resistance.
2. For return to neutral of the main valve, the spring center type and pressure-centred type are prepared as standard items.
3. A stroke limiter for adjusting spool stroke of the main valve can be installed.
4. The maximum working pressure is 34.3 MPa (350 kgf/cm²).

Type indication

DEH 52 F - 21 - 3 05 - 2 W D 12 AL P08 - S1 R -

Solenoid controlled pilot operated directional valve

Nominal dimension
52

Connection method
P = Gasket connection type
F = Flange connection type

Series number
Without choke valve = 20
With choke valve = 21

Position holding method (main valve)

Symbol	Explanation	Nominal dimension
		52
2	2 position, spring offset type	○
	3 position, spring center type	○
3	2 position, hydraulic offset type	○
	3 position, hydraulic center type	○

Spool type
Position holding method (olenoid valve)

Position holding method (main valve)
1 = 2 position, no spring type (with detent)
2 = 2 position, spring offset type
or
3 position, spring center type

Solenoid type
W = Wet type (with standard emergency manual operation)
(For the explosion proof type, please contact us.)

Input power supply
A = Alternating current
D = Direct current
R = AC/DC conversion

Input voltage

Direct current D	Alternating current A	AC/DC conversion R
12 : 12V 24 : 24V 48 : 48V	100 : 100V-50/60Hz 110V-60Hz	100 : 100V-50/60Hz 200 : 200V-50/60Hz
	120 : 110V-50Hz 120V-50/60Hz	
	200 : 200V-50/60Hz 220V-60Hz	
	240 : 220V-50Hz 240V-50/60Hz	

* For other power supply voltage, please contact us.

Type of hydraulic oil

No symbol = Mineral based hydraulic oil
V = Phosphate ester based hydraulic oil
W = Fatty ester based hydraulic oil
Water-glycol based hydraulic oil

Accessory parts of cover part provided or not

No symbol = No accessory parts
10 = with stroke limiter
11 = with stroke limiter on port A side
12 = with stroke limiter on port B side

Pilot pressure reducing valve provided or not
No symbol = without pressure reducing valve
R = with pressure reducing valve

Choke valve provided or not

No symbol = without choke valve
S1 = with meter-in choke valve
S2 = with meter-out choke valve

Pilot, Drain system

No symbol = external pilot, external drain
E = internal pilot, external drain
ET = internal pilot, internal drain
T = external pilot, internal drain

P port restriction of solenoid valve

No symbol = No restriction
P08 = Restriction contraction diameter ϕ 0.8mm
P10 = Restriction contraction diameter ϕ 1.0mm
P12 = Restriction contraction diameter ϕ 1.2mm
P15 = Restriction contraction diameter ϕ 1.5mm
P20 = Restriction contraction diameter ϕ 2.0mm
P25 = Restriction contraction diameter ϕ 2.5mm
P30 = Restriction contraction diameter ϕ 3.0mm
P40 = Restriction contraction diameter ϕ 4.0mm

Electric connection symbol

(For details, refer to the section of "Solenoid operated directional valve".)

Symbol	Pilot valve type
	DE10
AL	Integrated terminal box with lamp

Spool type symbol

Valve type	Flange connection type		Gasket connection type		Detailed hydraulic symbols (example: External pilot and external drain)	Simplified hydraulic symbols (example: External pilot and external drain)	
	Spool type	Hydraulic symbols	Transient state	Hydraulic symbols			Transient state
2 position valve							
	03						
	04						
	11						
	26						
3 position valve							
	05						
	06						
	07						
	08						
	10						
	12						
	13						
	17						
	18						
	19						
	20						
	21						
22							
23							

Specifications

Nominal dimension				52		
Maximum working pressure MPa (kgf/cm ²)	Port P, A, B, T, R (Note 1)			34.3 (350)		
	Port T (R)	(Note 2) Internal drain type	2 position valve 3 position valve Spring center type	Oil immersion type pilot valve		
		Port Y	External drain type		Oil immersion type pilot valve	
Highest pilot pressure MPa (kgf/cm ²) (Note 3)				24.5 (250)		
Lowest pilot pressure MPa (kgf/cm ²) (Note 4)	Spring center type			1.2 (12)		
	Hydraulic center type			1.5 (15)		
	Spring center type			1.2 (12)		
	Hydraulic center type			0.6 (6)		
Stroke volume of pilot part cm ³	Hydraulic center type			33		
	Other than hydraulic center type			66.5		
	Pilot pressure MPa (kgf/cm ²)			4.9 (50)	14.7 (150)	24.5 (250)
Switching time ms (AC solenoid) (Note 5)	Neutral → Switching position	2 position valve		110	90	70
		3 position valve	Spring center type	110	90	70
			Hydraulic center type	80	70	60
	Switching position → Neutral	2 position valve		110	90	80
		3 position valve	Spring center type	110	110	110
			Hydraulic center type	90	80	70
Pilot flow rate L/min				30		
Mass kg	Gasket connection type	Single solenoid type		82		
		Double solenoid type		83.5		
	Flange connection type	Single solenoid type		72		
		Double solenoid type		73.5		

(Note 1) If the valve is used with the internal pilot, the maximum working pressure of port P is 24.5 MPa (250 kgf/cm²).

(Note 2) If you wish to use the 3 position valve hydraulic center type with the internal drain, please contact us.

(Note 3) In the case of 3 position valve hydraulic center type with meter-out choke valve, the highest pilot pressure is 12.3 MPa (125 kgf/cm²).

(Note 4) When using the spool type 03, 07, 08, 06, 19, 20, 22 and 26 with the internal pilot, make sure that the difference between pilot pressure and drain pressure is always equal to or greater than the above pilot pressure.

(Note 5) Switching time from neutral to switching position of the DC solenoid is a value obtained by adding 60 ms to the numerical value in the above table.

Maximum flow rate

Maximum flow rate L/min		Working pressure MPa (kgf/cm ²)				
Nominal dimension	Spool type	6.9 (70)	13.7 (140)	20.6 (210)	27.5 (280)	34.3 (350)
		52 (A) (2 position valve spring offset type 3 position valve spring center type)	05, 10, 12, 13, 17, 18, 21 22, 23, 03, 04, 11, 26	2000	1400	1150
	06, 07, 08, 19, 20	1750	1230	1000	880	780

(Note)

- The following table shows numerical values in the case of the lowest pilot pressure.
- The maximum flow rate in the case of the 2 position valve hydraulic offset type and 3 position valve hydraulic center type is the flow rate of stage (A) regardless of the spool type.
- In the case of the hydraulic center type, when the pilot pressure is increased, the maximum flow rate is as follows regardless of the spool type and working pressure.

Nominal dimension	Pilot pressure MPa (kgf/cm ²)	Maximum flow rate L/min
52	2.5(25)	2000

Pressure drop characteristics (viscosity 36 mm²/s (cSt))

— Gasket connection type
 - - - Flange connection type

DEH52

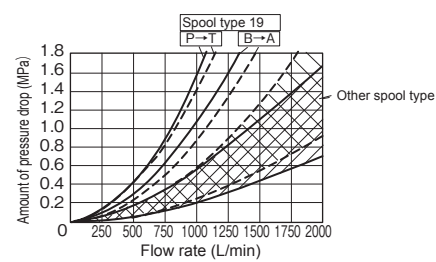
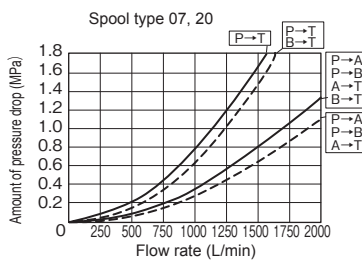
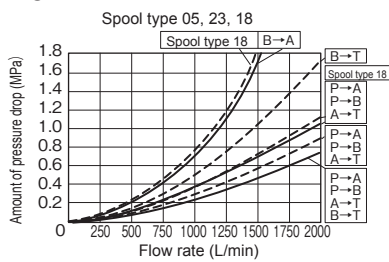

Pilot valve

Pilot valve type

The pilot valve uses the following solenoid operated directional valve.

Main valve		Pilot valve		
Nominal dimension	Spool neutral holding method	Type	Spool type	Hydraulic symbols
52	2 position valve spring offset type	DE10	04	Spool type 04
	2 position valve hydraulic offset type			Spool type 10
	3 position valve spring center type		10	Spool type 13
	3 position valve hydraulic center type		13	

* For the pilot valve specifications, refer to the section of the type number index "DE10".

Precautions in use

- If this valve is used with internal pilot, excessive flow rate may flow through the pilot valve, causing operation failure. Use a solenoid operated directional valve with P port restriction for the pilot valve.

Flange

Valve type	Flange type	Connection diameter	Mass
DEH52	TFAA-40	2B	2.6kg
	TFXA-40	2B	2.7kg

When you use a flange, please place an order for the above flange type.
For the dimension drawing, refer to page 16 of the appendix.

Accessories

● Mounting bolt

Type	Hexagon socket head cap thread	Quantity	Tightening torque N·m (kgf·cm)
DEH52 Gasket connection type	M20×100L	7 pcs.	431.2±64.6 (4400±660)

Option

● Accessory parts symbol of cover part

Schematic drawing	Valve type	2 position valve spring offset type	3 position valve spring center type	2 position valve hydraulic offset type	3 position valve hydraulic center type
	Symbol				
10					
	11				
	12				
List of installability	Nominal dimension	52	52	52	52
	Symbol	○	○	○	○
	10	○	○	○	○
	11	○	○	○	○
Explanation (example)	Symbol 12		with stroke limiter on port B side		

● Choke valve for adjusting stroke speed

● Handling method

When the adjust thread is turned clockwise, switching time of the spool becomes slow and when it is turned counterclockwise, switching time becomes fast.
When meter-in is changed to meter-out, the choke valve needs to be replaced.

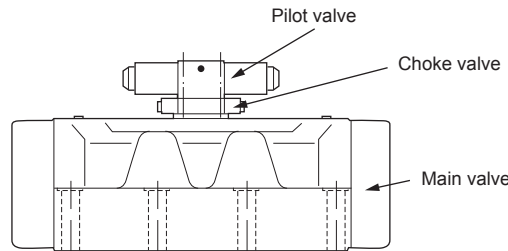

• In the case of meter-in (Choke valve: S-2TC10-20-E1)



• In the case of meter-out (Choke valve: S-2TC10-20-F1)



Nominal dimension	Choke valve type
52	S-2TC10-20- $\frac{E}{F}$ 1

Dimension drawing

● DEH52 (2 position valve - gasket connection type)

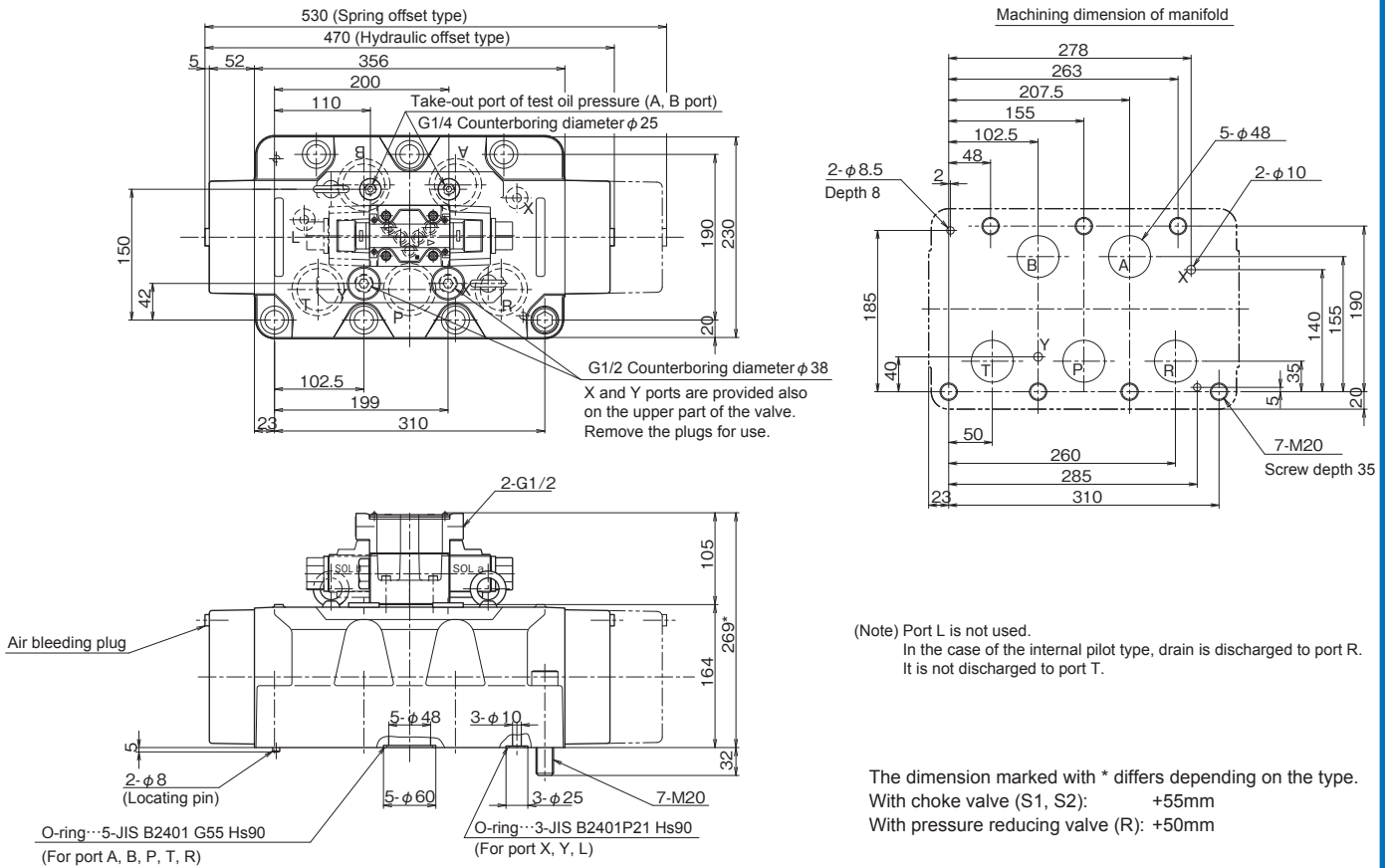

● DEH52 (2 position valve - flange connection type)

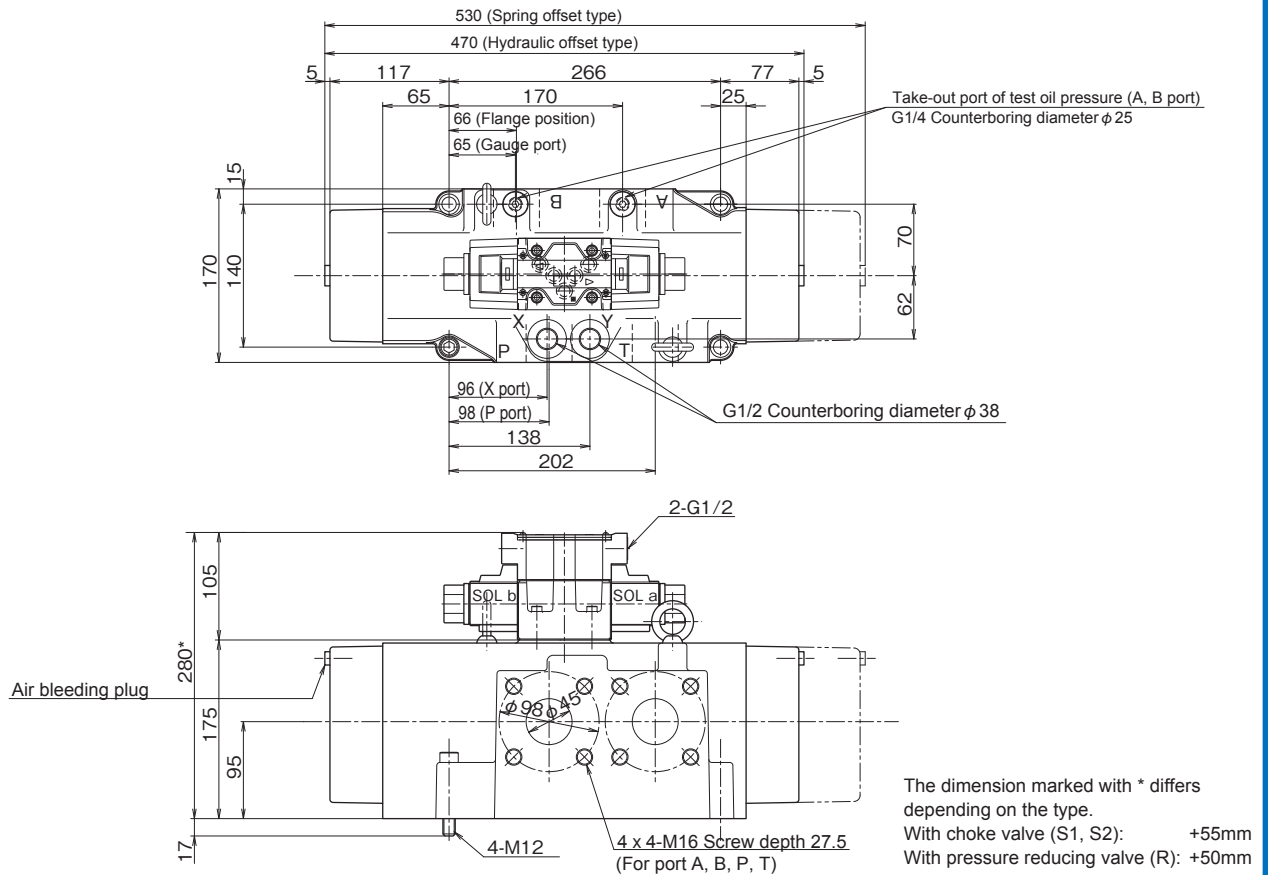

DEH52 (3 position valve - gasket connection type)

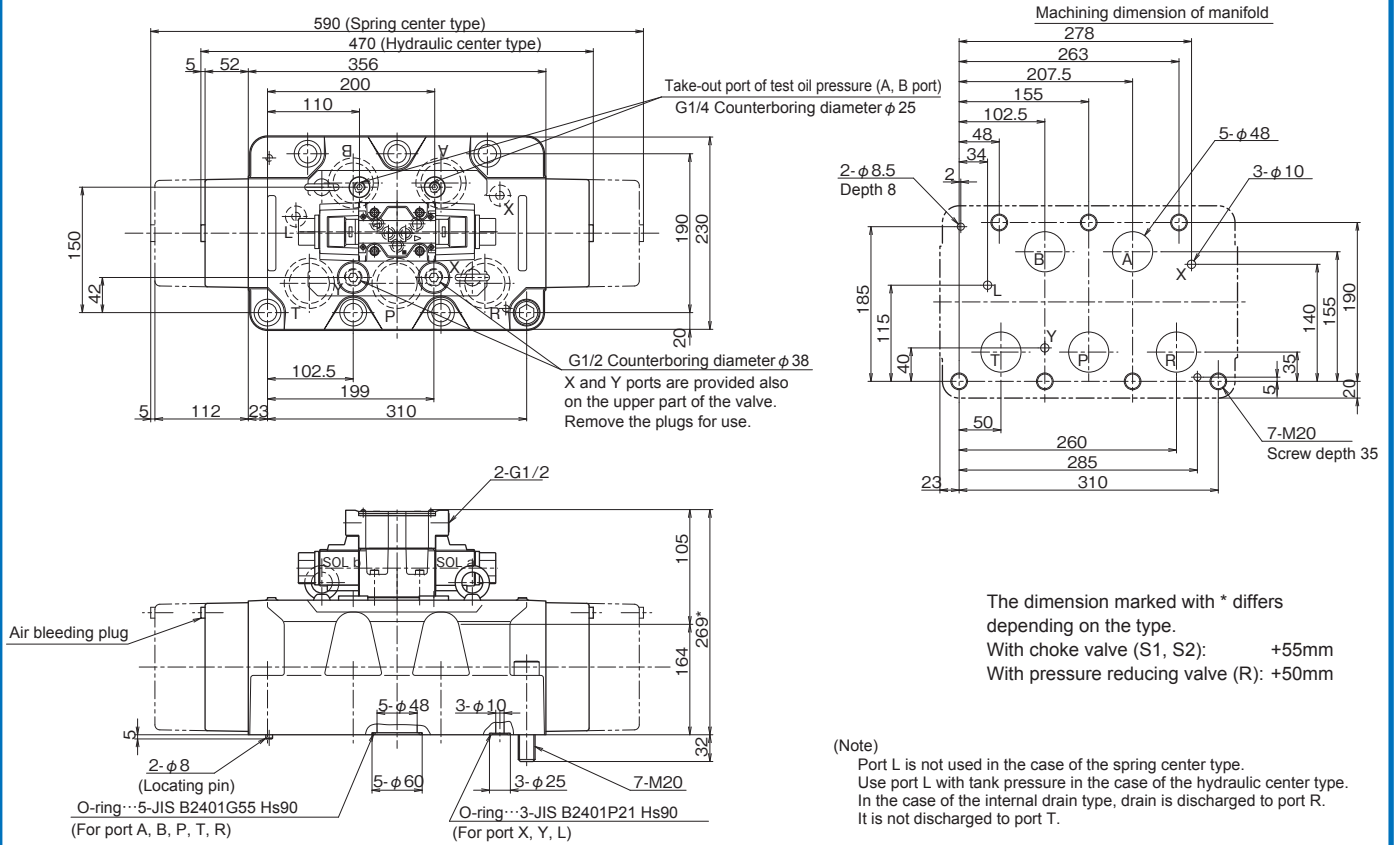

DEH52 (3 position valve - flange connection type)

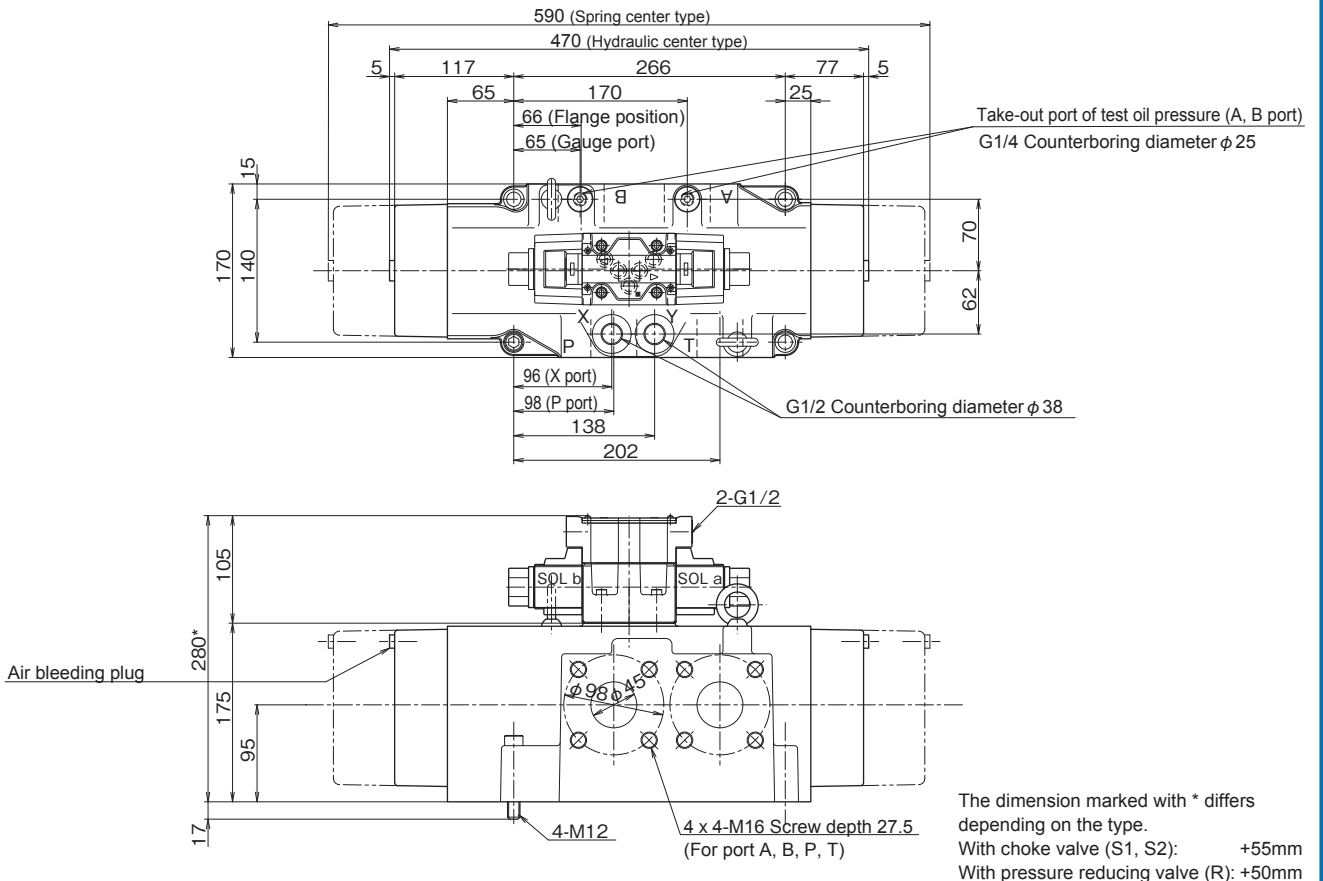

Pilot operated directional valve (1)

DH6/10

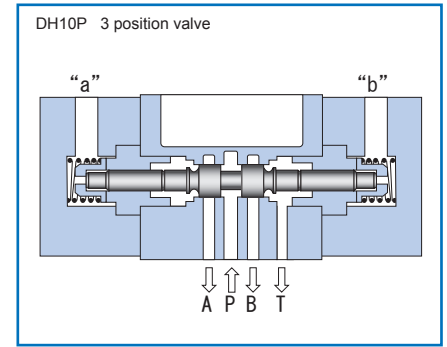
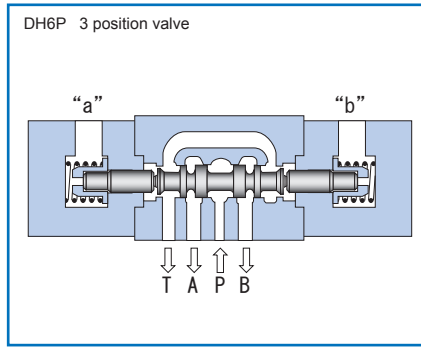
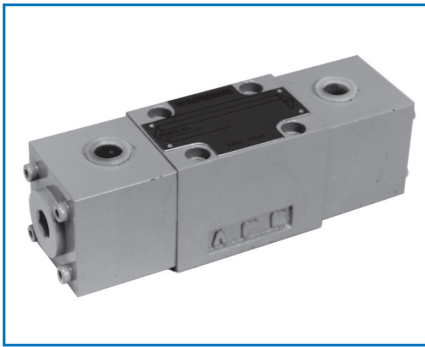

Overview

This pilot operated directional valve is used for controlling start and stop, and movement direction of the hydraulic system with pilot oil pressure.

Features

- Switching to high pressure and large flow rate is possible.

Type indication

DH 6 P - 10 - 2 05 - 6 P08 -

- Pilot operated directional valve
- Nominal dimension
6, 10
- Connection method
P = Gasket connection type
- Series number: 10
- Position holding method
2 = 2 position, spring offset type
3 = 3 position, spring center type
- Spool type
* Refer to "Spool type symbols".
- Type of hydraulic oil
No symbol = Mineral based hydraulic oil
V = Phosphate ester based hydraulic oil
W = Fatty ester based hydraulic oil
Water-glycol based hydraulic oil
- Presence/absence of P port restriction
No symbol = No restriction
P08 = Restriction contraction diameter ϕ 0.8mm
P10 = Restriction contraction diameter ϕ 1.0mm
P12 = Restriction contraction diameter ϕ 1.2mm
P15 = Restriction contraction diameter ϕ 1.5mm
P20 = Restriction contraction diameter ϕ 2.0mm
P25 = Restriction contraction diameter ϕ 2.5mm
P30 = Restriction contraction diameter ϕ 3.0mm
P40 = Restriction contraction diameter ϕ 4.0mm
- Pilot pressure symbol
6 = 0.59MPa (6kgf/cm²)
- Drain system
No symbol = External drain
T = Internal drain (2 position only)

Specifications

Nominal dimension		6	10
Maximum working pressure MPa (kgf/cm ²)	Port P, A, B	30.9 (315)	
	Port T	0.4 (4)	
Highest pilot pressure	MPa (kgf/cm ²)	24.5 (250) (Note 1)	13.7 (140) (Note 2)
Lowest pilot pressure	MPa (kgf/cm ²)	Pilot pressure + T port pressure	
Mass	kg	1.8	7.0

(Note 1) DH6P: The highest pressure should be 5.9 MPa (60 kgf/cm²) with spool type 07, 18, and 20.

(Note 2) DH10P: The highest pressure should be 5.9 MPa (60 kgf/cm²) with spool type 06, 07, 16, 18, and 20. In case of spool type 01 and 02, port T should be used as drain port.

Spool type symbol

Valve type		Hydraulic symbols	Transient state
Spool type			
2 position valve			
	01		
	03		
	04		
2 position valve	02		
	25		
3 position valve			
	05		
	06		
	07		
	08		
	10		
	12		
	13		
	16		
	17		
	18		
	20		
	21		
	22		
23			

Maximum flow rate (Maximum flow rate may show different values depending on pilot pressure and port T pressure.)

DH6 When DH6 pilot pressure is 2.0 MPa (20 kgf/cm²)

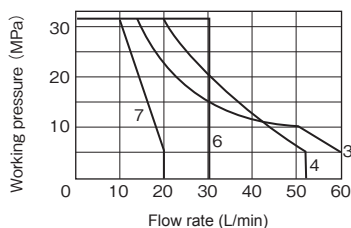
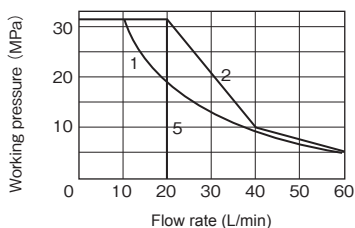

Curve number	Spool type
1	01, 02
2	03, 04, 25
3	05, 10, 12, 13, 17, 21, 22, 23
4	06, 16
5	20
6	07, 08
7	18

DH10 When DH6 pilot pressure is 2.0 MPa (20 kgf/cm²)

	Spool type	Working pressure MPa (kgf/cm ²)				
		4.9(50)	9.8(100)	19.6(200)	24.5(250)	30.9(315)
Flow rate of each spool (L/min)	05	80	80	75	60	60
	03, 08, 10, 12, 13, 17, 21, 22, 23	80	80	75	50	45
	04, 06, 07, 16, 18, 20, 25	75	70	60	50	45
	01, 02	50	45	35	30	25

Pressure drop characteristics

- Similar to those of solenoid operated directional valve (DE6, DE10)
Refer to the section of the type number index "DE6" and "DE10".

Sub-plate

Valve type	Sub-plate type	Connection diameter	Mass
DH6P	P-DE6R14-0	Rc 1/4	1.0kg
	P-DE6G14-0	G 1/4	
	P-DE6R38-0	Rc 3/8	1.3kg
	P-DE6G38-0	G 3/8	
DH10P	P-DE10R38-0	Rc 3/8	2.7kg
	P-DE10G38-0	G 3/8	
	P-DE10R12-0	Rc 1/2	
	P-DE10G12-0	G 1/2	

When you use a sub-plate, please place an order for the above sub-plate type.
For the dimension drawing, refer to pages 9 and 11 of the appendix.

Accessories

Mounting bolt

Type	Hexagon socket head cap thread	Quantity	Tightening torque N·m (kgf·cm)
DH6	M5×50L	4 pcs.	6.9±1.0 (70±10.5)
DH10	M6×50L	4 pcs.	11.8±1.7 (120±18)

Pilot port

A valve in which the pilot is a G thread (JISB2351 O-ring seal type) is available.
Besides, a valve in which a pilot port is provided on the gasket surface is prepared.
Please contact us for the details.

Dimension drawing

●DH6

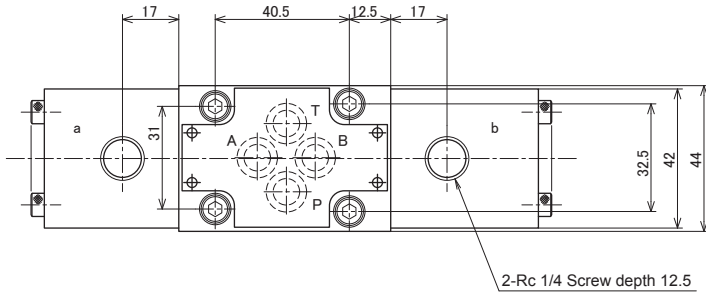

Machining dimension of manifold

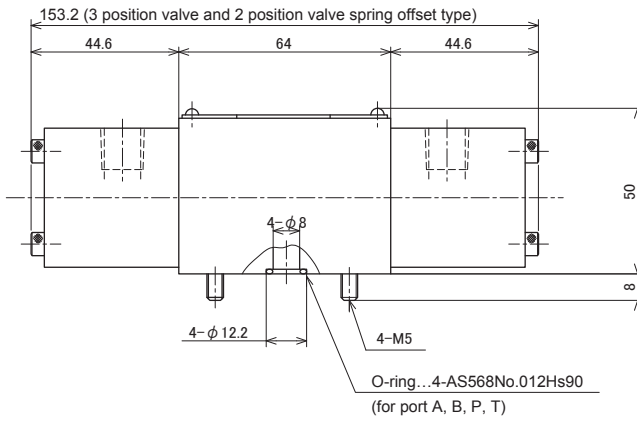
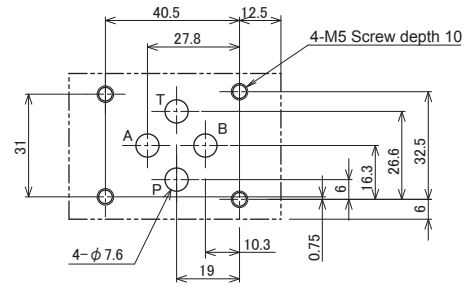

●DH10

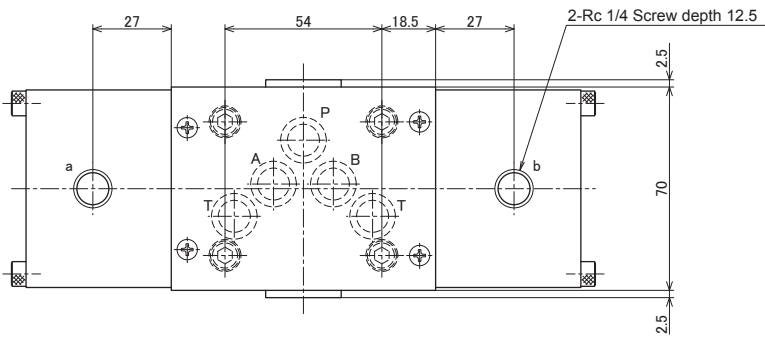

Machining dimension of manifold

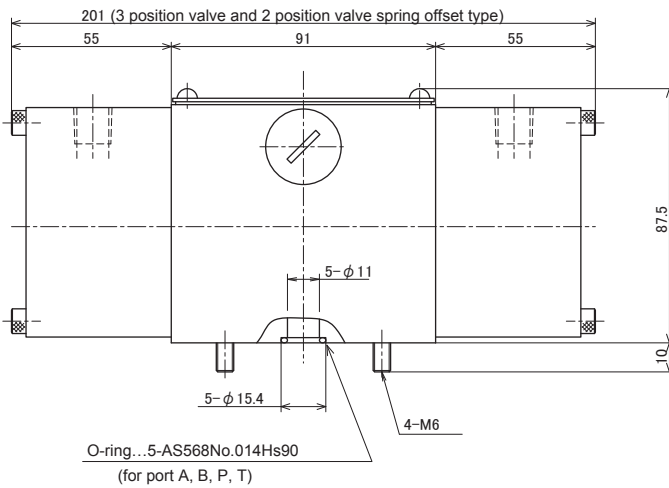
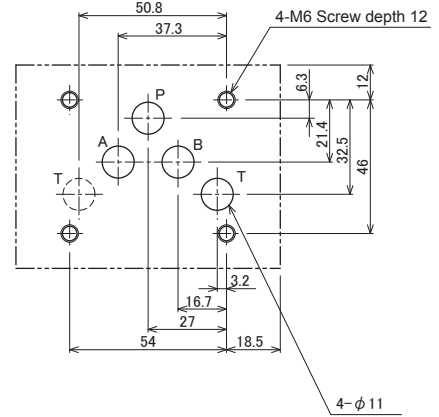

There is T port at two locations and either of the two may be used.

Pilot operated directional valve (2)

DH16 to 32

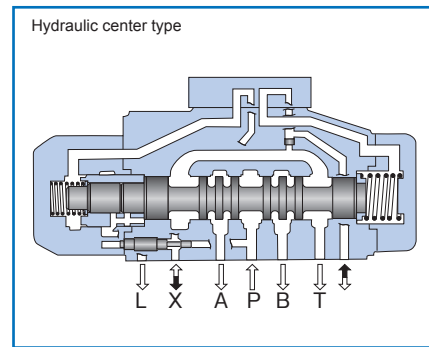
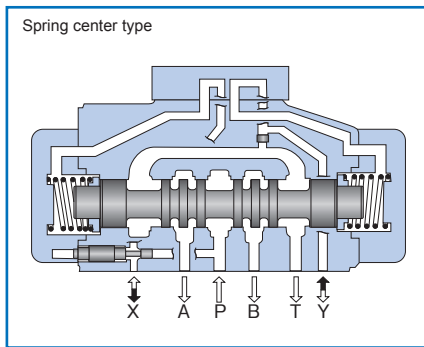
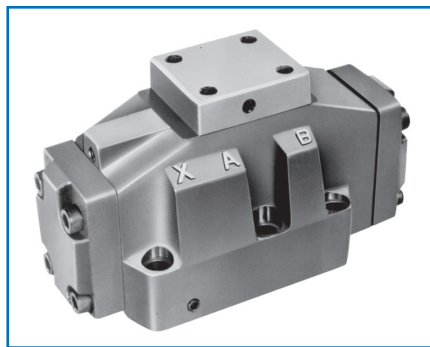

Overview

This pilot operated directional valve is used for controlling start and stop, and movement direction of the hydraulic system with pilot oil pressure.

Features

1. The improvement of internal coring shape and spool shape of the casing has substantially reduced the flow resistance.
2. For return to neutral of the main valve, the spring center type and pressure-centred type are prepared as standard items.
3. A stroke limiter for adjusting spool stroke of the main valve can be installed.
4. The maximum working pressure is 34.3 MPa (350 kgf/cm²).

Type indication

DH 16 P - 11 - 205 - S1 -

<p>Pilot operated directional valve</p> <p>Nominal dimension 16, 22, 32</p> <p>Connection method P = Gasket connection type</p> <p>Series number without choke valve = 10 with choke valve = 11</p> <p>Position holding method 2 = 2 position, spring offset type 3 = 2 position, hydraulic offset type 3 = 2 position, hydraulic center type</p> <p>Spool type * Refer to "Spool type symbols".</p>	<p>Type of hydraulic oil No symbol = Mineral based hydraulic oil V = Phosphate ester based hydraulic oil W = Fatty ester based hydraulic oil Water-glycol based hydraulic oil</p> <p>Accessory parts of cover part provided or not No symbol = No accessory parts 10 = with stroke limiter 11 = with stroke limiter on port A side 12 = with stroke limiter on port B side</p> <p>Choke valve provided or not No symbol = without choke valve S1 = with meter-in choke valve (Note 1) S2 = with meter-out choke valve (Note 1)</p> <p>Drain system No symbol = External drain T = Internal drain (spring offset type only)</p>
--	--

Sub-plate

Valve type	Sub-plate type	Connection diameter	Mass
DH16	P-DEH16R34-0	Rc 3/4	7.0kg
	P-DEH16G34-0	G 3/4	
	P-DEH16R1-0	Rc 1	14.5kg
	P-DEH16G1-0	G 1	
DH22	P-DEH22R1-0	Rc 1	11kg
	P-DEH22G1-0	G 1	
	P-DEH22R54-0	Rc 1 1/4	24kg
	P-DEH22G54-0	G 1 1/4	
	P-DEH22R32-0	Rc 1 1/2	
	P-DEH22G32-0	G 1 1/2	
DH32	P-DEH32R32-0	Rc 1 1/2	19kg
	P-DEH32G32-0	G 1 1/2	

* Items in (Note 1) are similar to those of the solenoid controlled pilot operated directional valve (DEH16, 22, 32). Refer to the section of the solenoid controlled pilot operated directional valve (1).

Accessories

● Mounting bolt

Type	Hexagon socket head cap thread	Quantity	Tightening torque N·m (kgf·cm)
DH16	M6×55L	2 pcs.	11.8± 1.7 (120± 18)
	M10×60L	4 pcs.	56.8± 8.5 (580± 87)
DH22	M12×60L	6 pcs.	98.0±14.7 (1000±150)
DH32	M20×80L	6 pcs.	431.2±64.6 (4400±660)

When you use a sub-plate, please place an order for the above sub-plate type. For the dimension drawing, refer to pages 9,10 and 11 of the appendix.

Spool type symbol

Valve type		Hydraulic symbols	Transient state
Spool type			
2 position valve		<p>Spring offset type</p> <p>Hydraulic offset type</p>	
	03		
	04		
	11		
	26		
3 position valve		<p>Spring center type</p> <p>Hydraulic center type</p>	
	05		
	06		
	07		
	08		
	10		
	12		
	13		
	17		
	18		
	19		
	20		
	21		
	22		
23			

Specifications

Nominal dimension		16	22	32	
Maximum working pressure MPa (kgf/cm ²)	Port A, B, P	34.3 (350)			
	Port T	24.5 (250)			
Highest pilot pressure	MPa (kgf/cm ²)	24.5 (250)			
Lowest pilot pressure MPa (kgf/cm ²)	3 position valve spring center type 3 position valve hydraulic center type	0.78 (8.0)			
	2 position valve spring offset type	0.98 (10.0)			
	2 position valve hydraulic offset type	0.5 (5.0)			
Stroke volume of pilot part cm ³	2 position valve spring offset type 2 position valve hydraulic offset type	8.9	19.3	70.7	
	3 position valve spring center type	4.45	9.65	35.35	
	3 position valve hydraulic center type	Position "o"→"a"	2.30	5.0	17.25
		Position "a"→"o"	2.15	4.65	18.1
		Position "o"→"b"	4.45	9.65	35.35
Position "b"→"o"		2.30	4.65	17.25	
Opening area at spool neutral position (with spool 10 as 100%)	Spool 17, 22	16%			
	Spool 23	3%			
Mass	kg	7.5	13	49	

Maximum flow rate

Nominal dimension	Spool type	Maximum flow rate L/min	Working pressure MPa (kgf/cm ²)				
			7 (70)	14 (140)	20.6 (210)	27.4 (280)	34.3 (350)
16	(A) 05, 10, 12, 13, 17, 18, 21 22, 23, 03, 04, 11, 26	* 240	240	205	180	170	
	06	200	145	115	100	90	
	07, 08, 19, 20	220	160	130	110	100	
22	(A) 05, 10, 12, 13, 17, 18, 21 22, 23, 03, 04, 11, 26	* 450	450	370	320	300	
	06, 07, 08, 19, 20	360	250	210	180	160	
32	(A) 05., 10, 12, 13, 17, 18, 21 22, 23, 03, 04, 11, 26	* 1100	1050	860	750	680	
	06, 07, 08, 19, 20	820	630	510	450	400	

- (Note) ● The above table shows numerical values in the case of the lowest pilot pressure.
 ● The maximum flow rate in the case of the 2 position valve hydraulic offset type and 3 position valve hydraulic center type is the flow rate of stage (A) regardless of the spool type, and is the flow rate marked with * regardless of the spool type and pressure if pilot pressure is 1.5 MPa (15 Kgf/cm²) or higher.

Pressure drop characteristics

- Similar to those of solenoid controlled pilot operated directional valve (DEH16, 22, 32)
Refer to the section of the type number index "DEH16, 22, 32".

Dimension drawing

●DH16 (2 position valve)

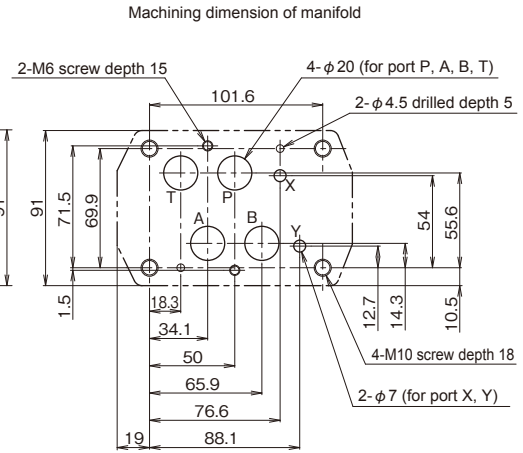
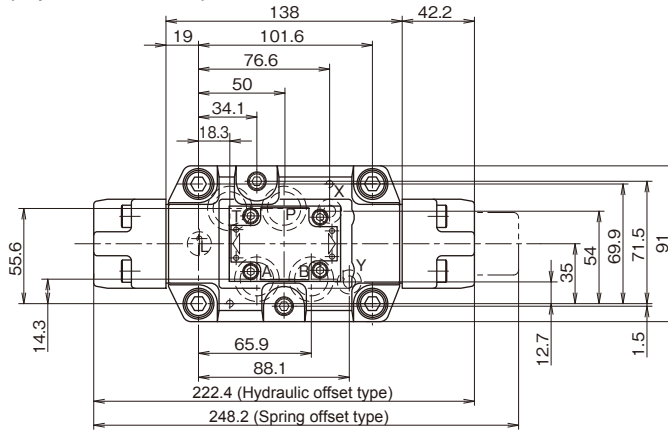

(Note) Port L is not used.

The dimension marked with * differs depending on the type.
With choke valve (S1, S2): +40 mm

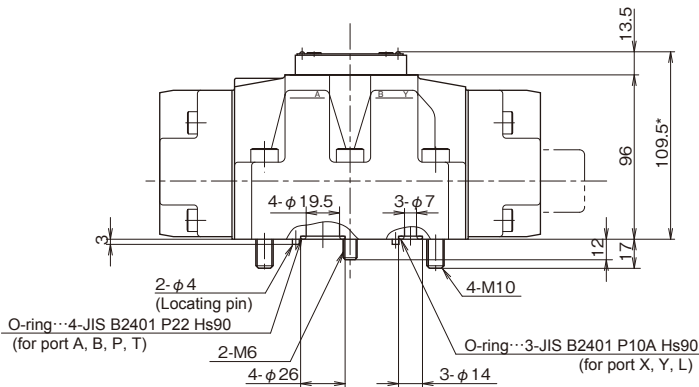

●DH16 (3 position valve)

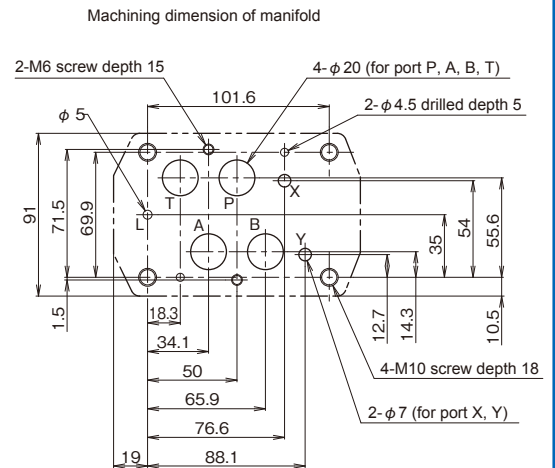
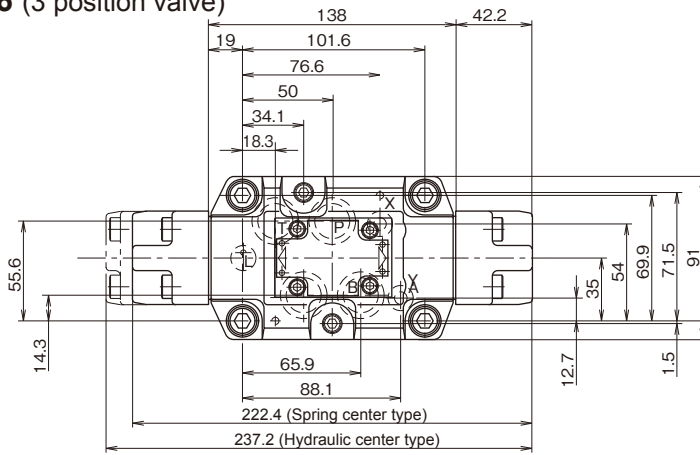

(Note) Port L is not used in the case of the spring center type.
Use port L with tank pressure in the case of the hydraulic center type.

The dimension marked with * differs depending on the type.
With choke valve (S1, S2): +40 mm

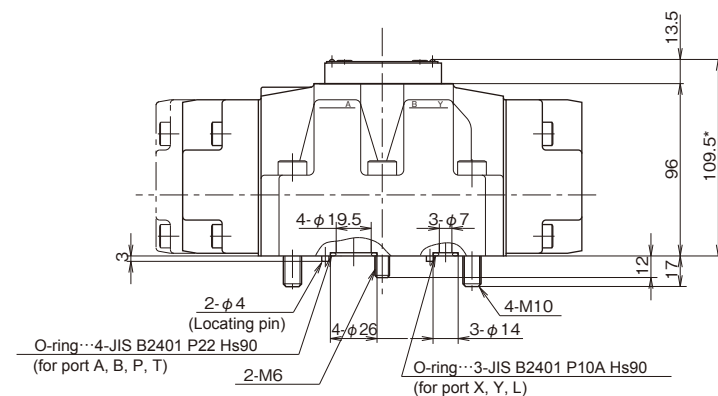

●DH22 (2 position valve)

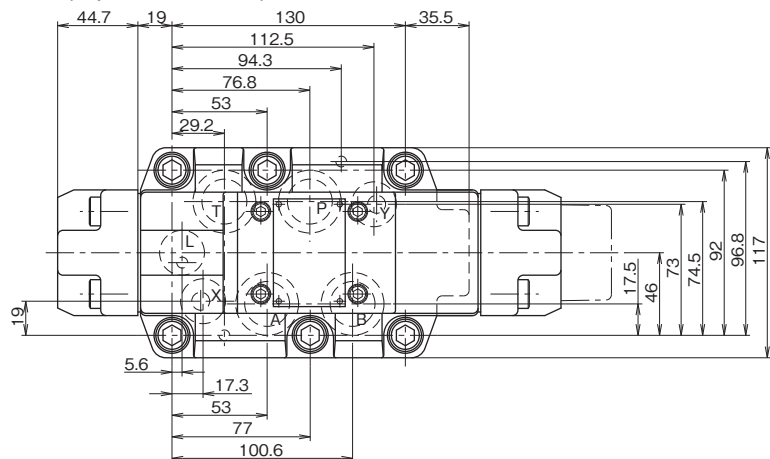

Machining dimension of manifold

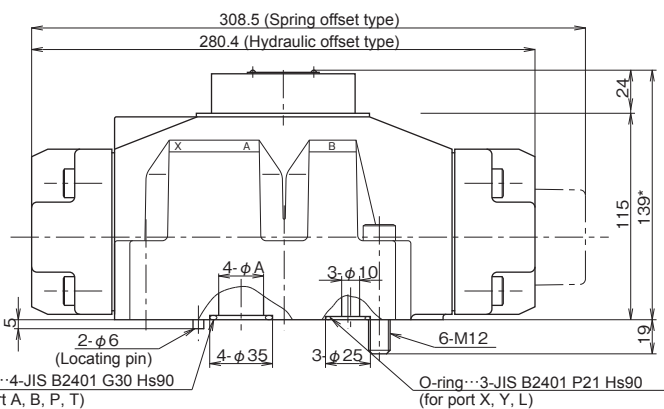
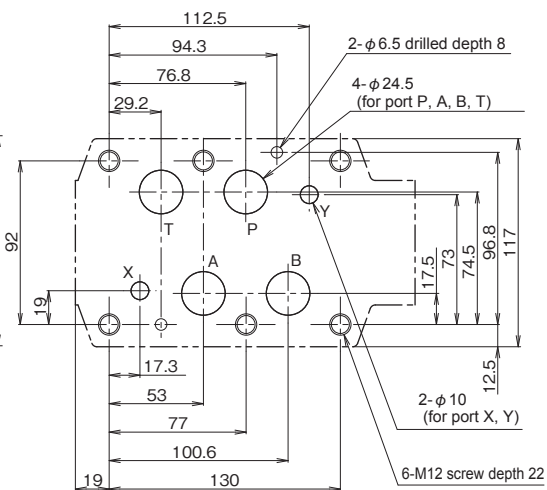

(Note) Port L is not used.

The dimension marked with * differs depending on the type.

With choke valve (S1, S2): +55 mm

Dimension	φ A
Port P	24
Port A, B	24.5
Port T	25

O-ring...4-JIS B2401 G30 Hs90 (for port A, B, P, T)

O-ring...3-JIS B2401 P21 Hs90 (for port X, Y, L)

●DH22 (3 position valve)

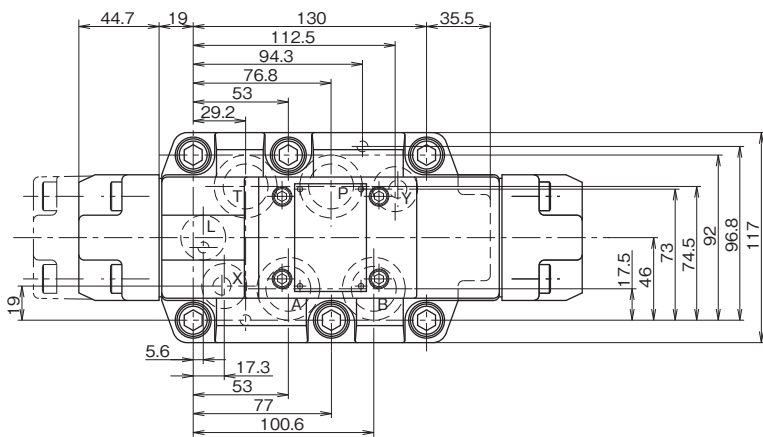

Machining dimension of manifold

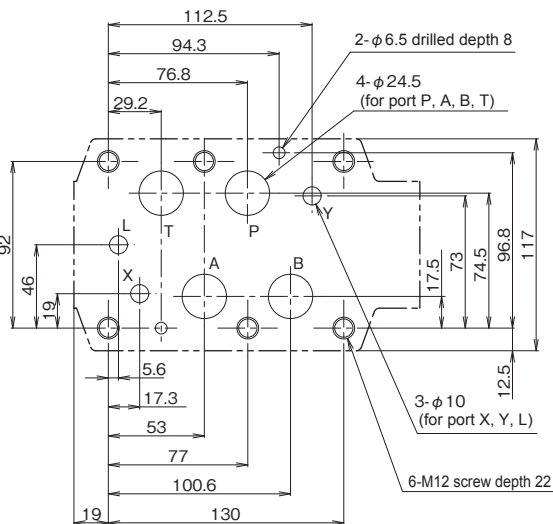

(Note) Port L is not used in the case of the spring center type.
Use port L with tank pressure in the case of the hydraulic center type.

The dimension marked with * differs depending on the type.

With choke valve (S1, S2): +55 mm

Dimension	φ A
Port P	24
Port A, B	24.5
Port T	25

O-ring...4-JIS B2401 G30 Hs90 (for port A, B, P, T)

O-ring...3-JIS B2401 P21 Hs90 (for port X, Y, L)

●DH32 (2 position valve)

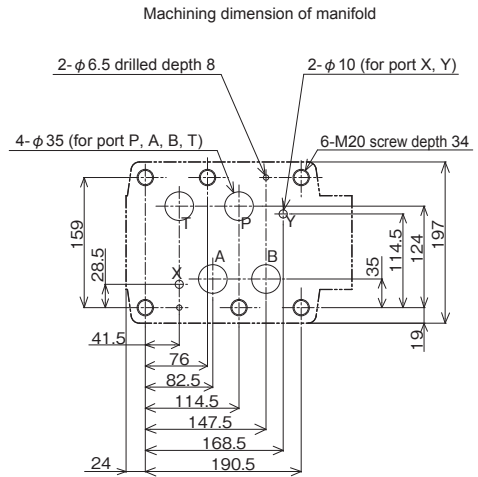
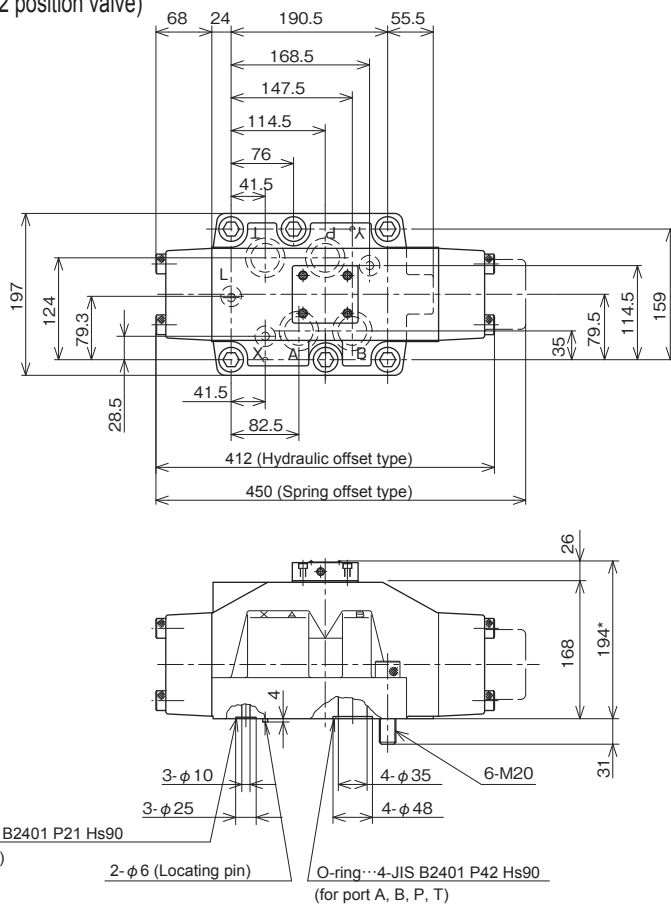

(Note) Port L is not used.

The dimension marked with * differs depending on the type.
With choke valve (S1, S2): +55 mm

●DH32 (3 position valve)

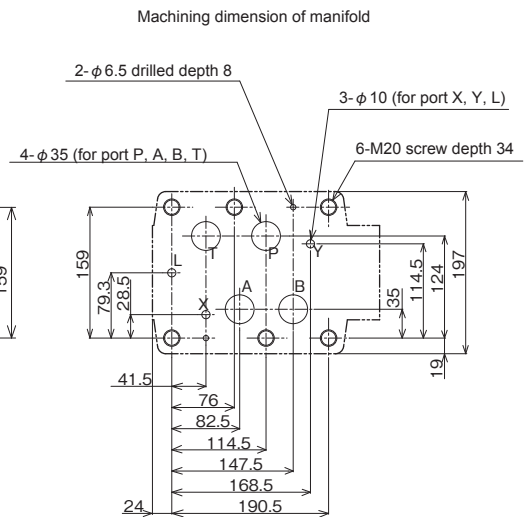
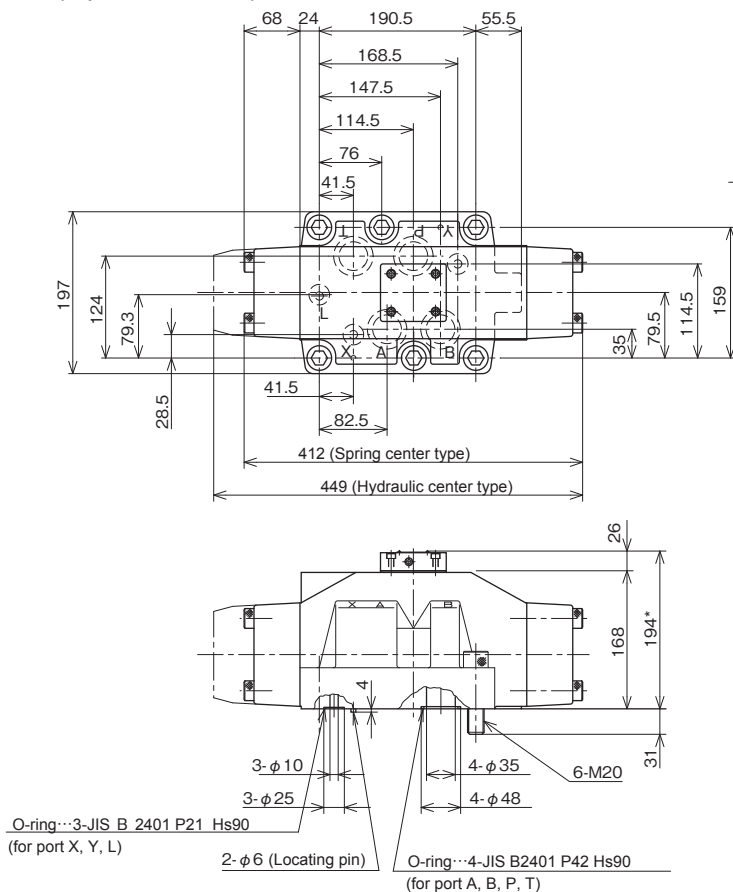

(Note) Port L is not used in the case of the spring center type.
Use port L with tank pressure in the case of the hydraulic center type.

The dimension marked with * differs depending on the type.
With choke valve (S1, S2): +55 mm

Pilot operated directional valve (3)

DH52

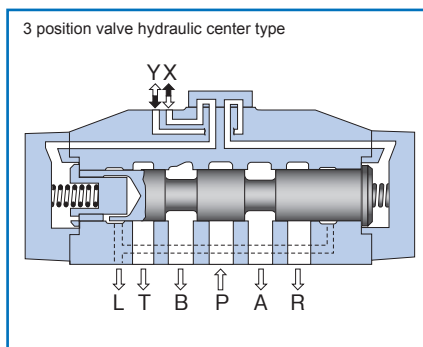

Overview

This pilot operated directional valve is used for controlling start and stop, and movement direction of the hydraulic system with pilot oil pressure.

Features

1. The improvement of internal coring shape and spool shape of the casing has substantially reduced the flow resistance.
2. For return to neutral of the main valve, the spring center type and pressure-centred type are prepared as standard items.
3. The maximum working pressure is 34.3 MPa (350 kgf/cm²).

Type indication

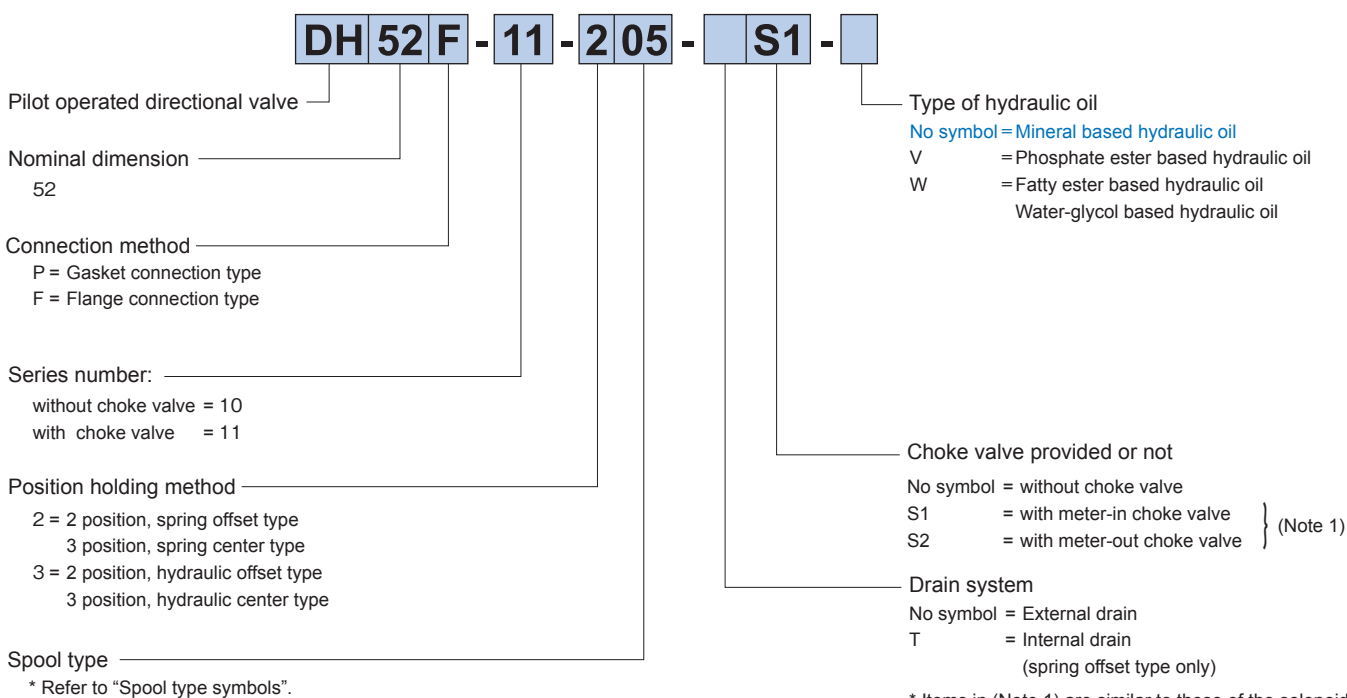

* Items in (Note 1) are similar to those of the solenoid controlled pilot operated directional valve (DEH52). Refer to the section of the solenoid controlled pilot operated directional valve (2).

Specifications

Nominal dimension		52
Maximum working pressure MPa (kgf/cm ²)	Port A, B, P, T, R	34.3 (350)
	Port X, Y	24.5 (250)
Highest pilot pressure	MPa (kgf/cm ²) (Note)	24.5 (250)
Highest pilot pressure MPa (kgf/cm ²)	3 position valve spring center type	1.2 (12)
	3 position valve hydraulic center type	1.5 (15)
	2 position valve spring offset type	1.2 (12)
	2 position valve hydraulic offset type	0.6 (6)
Stroke volume of pilot part cm ³	3 position valve hydraulic center type	33
	Valves other than the above	66.5
Mass kg	Gasket connection type	80
	Flange connection type	70

(Note 3) In the case of 3 position valve hydraulic center type with meter-out choke valve, the highest pilot pressure is 12.3 MPa (125 kgf/cm²).

Maximum flow rate/Pressure drop characteristics

- Similar to those of solenoid controlled pilot operated directional valve (2) (DEH52). Refer to the section of the type number index “DEH52”.

Flange

Valve type	Flange type	Connection diameter	Mass
DH52	TFAA-40	2B	2.6kg
	TFXA-40	2B	2.7kg

When you use a flange, please place an order for the above flange type.

For the dimension drawing, refer to page 16 of the appendix.

Accessories

● Mounting bolt

Type	Hexagon socket head cap thread	Quantity	Tightening torque N·m (kgf·cm)
DEH52 Gasket connection type	M20 × 100L	7 pcs.	431.2 ± 64.6 (4400 ± 660)

Spool type symbol

Valve type		Gasket connection type		Gasket connection type		
Spool type	Hydraulic symbols	Transient state	Hydraulic symbols	Transient state	Transient state	
2 position valve	<p>Spring offset type</p>		<p>Spring offset type</p>			
	<p>Hydraulic offset type</p>		<p>Hydraulic offset type</p>			
	03					
	04					
	11					
26						
3 position valve	<p>Spring center type</p>		<p>Spring center type</p>			
	<p>Hydraulic center type</p>		<p>Hydraulic center type</p>			
	05					
	06					
	07					
	08					
	10					
	12					
	13					
	17					
	18					
	19					
	20					
	21					
22						
23						

Dimension drawing

●DH52 (2 position valve - gasket connection type)

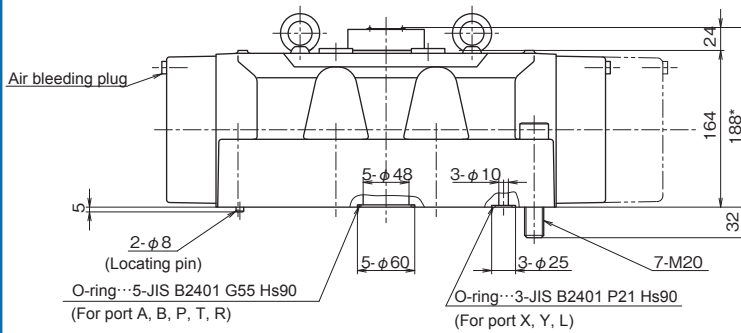
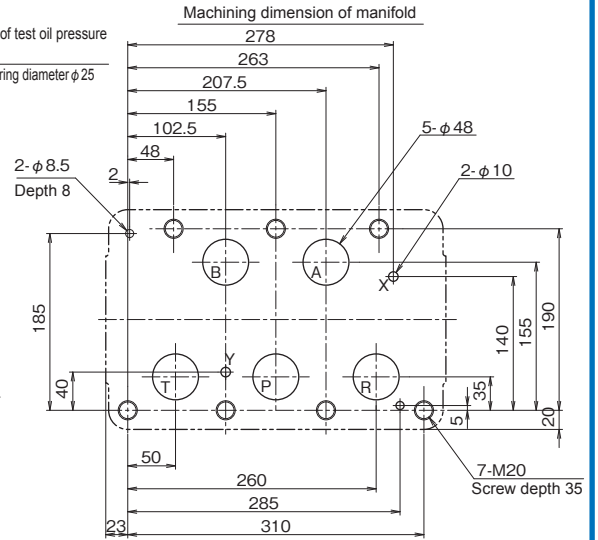
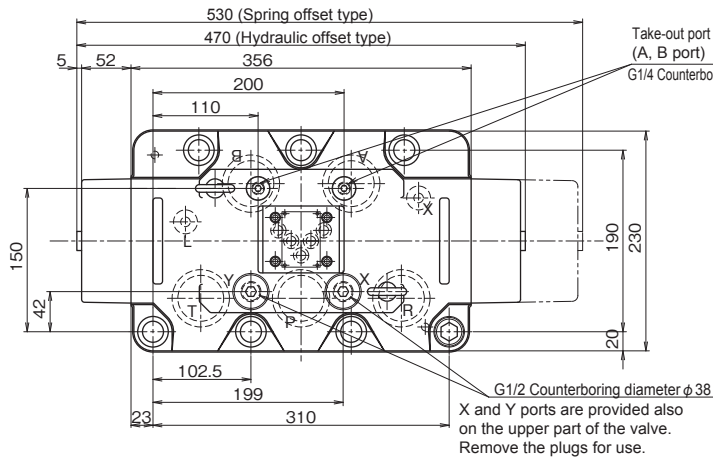

The dimension marked with * differs depending on the type.
With choke valve (S1, S2): +55mm

Note)
1. Block L port with a sub-plate.

●DH52 (2 position valve - flange connection type)

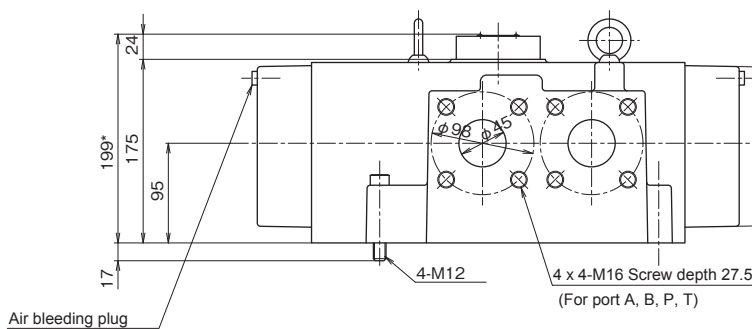
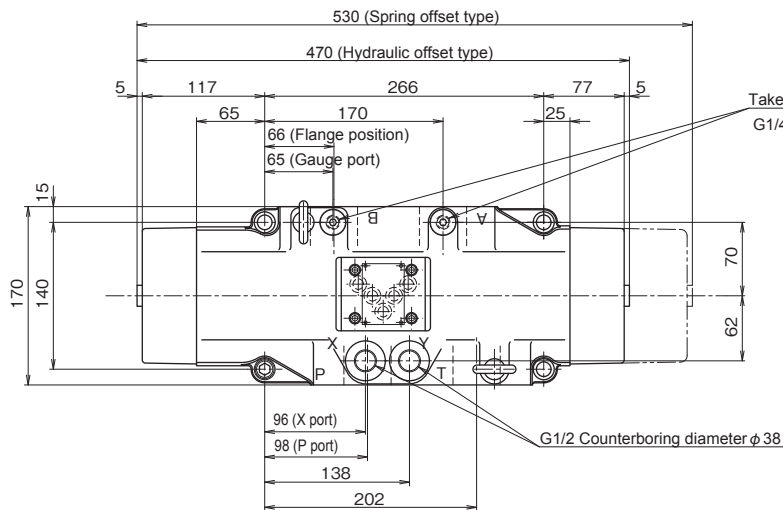

The dimension marked with * differs depending on the type.
With choke valve (S1, S2): +55mm

●DH52 (3 position valve - gasket connection type)

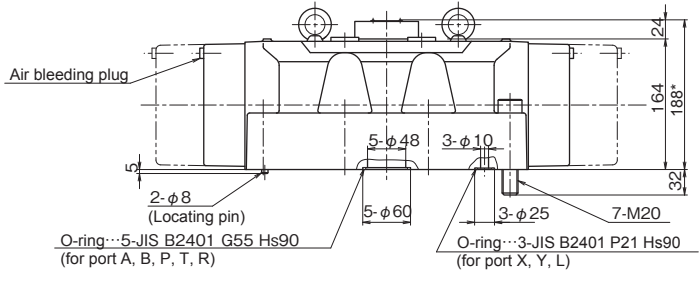
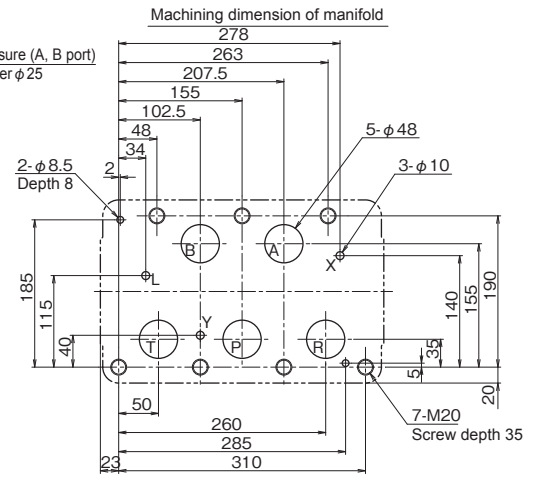
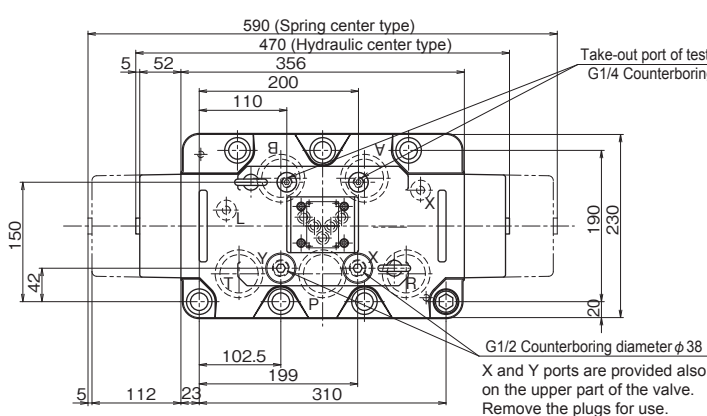

The dimension marked with * differs depending on the type.
With choke valve (S1, S2): +55mm

- Note)
1. Port L is not used in the case of the spring center type.
 2. Use port L with tank pressure in the case of the hydraulic center type.

●DH52 (3 position valve - flange connection type)

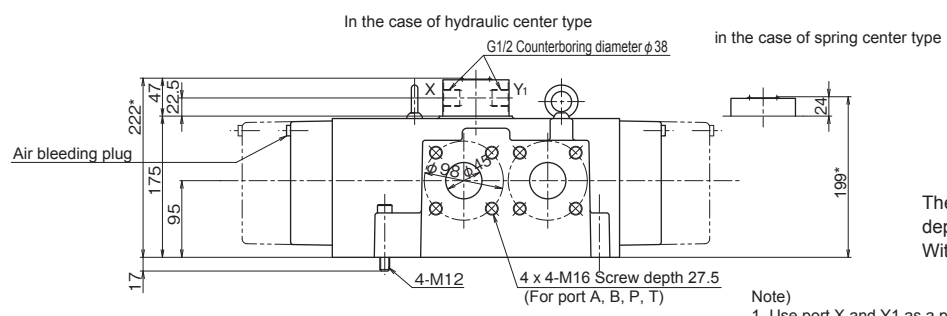
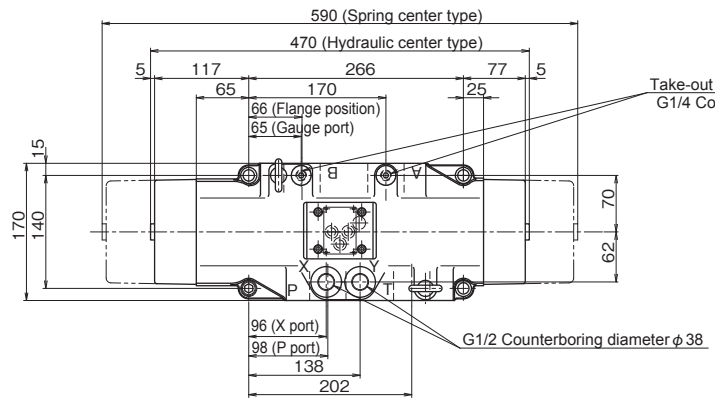

The dimension marked with * differs depending on the type.
With choke valve (S1, S2): +55mm

- Note)
1. Use port X and Y1 as a pilot port in the case of the hydraulic center type.
Use port Y with tank pressure.

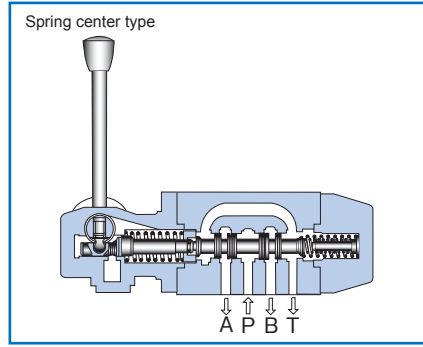

Overview

This manual selector valve is used for controlling start and stop, and movement direction of the hydraulic system with handle operation.

Type indication

DM 6 P - 10 - 105 / P08 -

<p>Manual selector valve</p> <p>Nominal dimension 6, 10</p> <p>Connection method P = Gasket connection type</p> <p>Series number: 10</p> <p>Position holding method 1 = No spring type, detent type 2 = Spring offset type Spring center type</p>	<p>Type of hydraulic oil No symbol = Mineral based hydraulic oil V = Phosphate ester based hydraulic oil W = Fatty ester based hydraulic oil Water-glycol based hydraulic oil</p> <p>Presence/absence of P port restriction No symbol = No restriction P08 = Restriction contraction diameter ϕ0.8mm P10 = Restriction contraction diameter ϕ1.0mm P12 = Restriction contraction diameter ϕ1.2mm</p> <p>Spool type * Refer to "Spool type symbols".</p>	<p>Type of hydraulic oil</p> <p>Presence/absence of P port restriction</p> <p>Spool type</p>
---	---	--

Specifications

Nominal dimension		6	10
Maximum working pressure (Note 1) MPa (kgf/cm ²)	Port A, B, P	30.9 (315)	
	Port T	2.9 (30)	14.7 (150)
Operating force during switching N (kgf)		19.6 to 29.4 (2.0 to 3.0)	15.7 to 26.5 (1.6 to 2.7)
Mass kg		1.4	4.0

(Note 1) If working pressure exceeds the highest pressure of port T when the spool type is A or B, use port T as a drain port.
 • The opening area at spool neutral position is "spool type 23 = 3%, spool type 17 = 6%" when spool type 10 is assumed to be 100%.

Accessories

Mounting bolt

Type	Hexagon socket head cap thread	Quantity	Tightening torque N·m (kgf·cm)
DM6	M5×50L	4 pcs.	6.9± 1.0 (70±10)
DM10	M6×50L	4 pcs.	11.8± 1.8 (120±18)

Sub-plate

Valve type	Sub-plate type	Connection diameter	Mass
DM6P	P-DE6G14-0	G $\frac{1}{4}$	1.0kg
	P-DE6R14-0	Rc $\frac{1}{4}$	
	P-DE6G38-0	G $\frac{3}{8}$	1.3kg
	P-DE6R38-0	Rc $\frac{3}{8}$	
DM10P	P-DE10G38-0	G $\frac{3}{8}$	2.1kg
	P-DE10R38-0	Rc $\frac{3}{8}$	
	P-DE10G12-0	G $\frac{1}{2}$	
	P-DE10R12-0	Rc $\frac{1}{2}$	

When you use a sub-plate, please place an order for the above sub-plate type.
 For the dimension drawing, refer to pages 9 and 11 of the appendix.

Spool type symbol

Valve type	Hydraulic symbols	Transient state	Spool type	DM (lever type)	
				6	10
2 position valve					
			01	○	○
			02	—	○
			03	○	○
			04	○	○
			25	—	○
			02	○	—
			25	○	—
	3 position valve				
			05	○	○
			06	○	○
			07	○	○
			08	○	○
			10	○	○
			12	○	○
			13	○	○
			16	○	○
			17	○	○
			18	○	○
			20	○	○
			21	○	○
			22	○	○
			23	○	○

Maximum flow rate

DM6

DM6		DM6																													
Spring offset type Spring center type		No spring type with detent																													
<table border="1"> <thead> <tr> <th>Curve number</th> <th>Spool type</th> </tr> </thead> <tbody> <tr> <td>1</td> <td>03, 04, 05, 07, 08, 10, 12, 13, 17, 18, 21, 23, 25</td> </tr> <tr> <td>2</td> <td>01, 02</td> </tr> <tr> <td>3</td> <td>22</td> </tr> <tr> <td>4</td> <td>06, 16</td> </tr> <tr> <td>5</td> <td>20</td> </tr> </tbody> </table>	Curve number	Spool type	1	03, 04, 05, 07, 08, 10, 12, 13, 17, 18, 21, 23, 25	2	01, 02	3	22	4	06, 16	5	20		<table border="1"> <thead> <tr> <th>Curve number</th> <th>Spool type</th> </tr> </thead> <tbody> <tr> <td>1</td> <td>03, 04, 08, 13, 25</td> </tr> <tr> <td>2</td> <td>05, 10, 12, 21, 23</td> </tr> <tr> <td>3</td> <td>01, 02</td> </tr> <tr> <td>4</td> <td>07, 20</td> </tr> <tr> <td>5</td> <td>06</td> </tr> <tr> <td>4</td> <td>22</td> </tr> <tr> <td>5</td> <td>16</td> </tr> </tbody> </table>	Curve number	Spool type	1	03, 04, 08, 13, 25	2	05, 10, 12, 21, 23	3	01, 02	4	07, 20	5	06	4	22	5	16	
Curve number	Spool type																														
1	03, 04, 05, 07, 08, 10, 12, 13, 17, 18, 21, 23, 25																														
2	01, 02																														
3	22																														
4	06, 16																														
5	20																														
Curve number	Spool type																														
1	03, 04, 08, 13, 25																														
2	05, 10, 12, 21, 23																														
3	01, 02																														
4	07, 20																														
5	06																														
4	22																														
5	16																														

DM10

	Spool type	Working pressure MPa (kgf/cm ²)				
		4.9 (50)	9.8 (100)	19.6 (200)	24.5 (250)	30.9 (315)
Flow rate (L/min)	05	80	80	75	60	60
	03, 08, 10, 12, 13, 21, 22, 23	80	80	75	50	45
	04, 06, 07, 16, 18, 20, 25	75	70	60	50	45
	01, 02	50	45	35	30	25

Pressure drop characteristics

- Similar to those of solenoid operated directional valve (DE6, DE10). Refer to the section of the type number index "DE6" and "DE10".

Dimension drawing

DM6

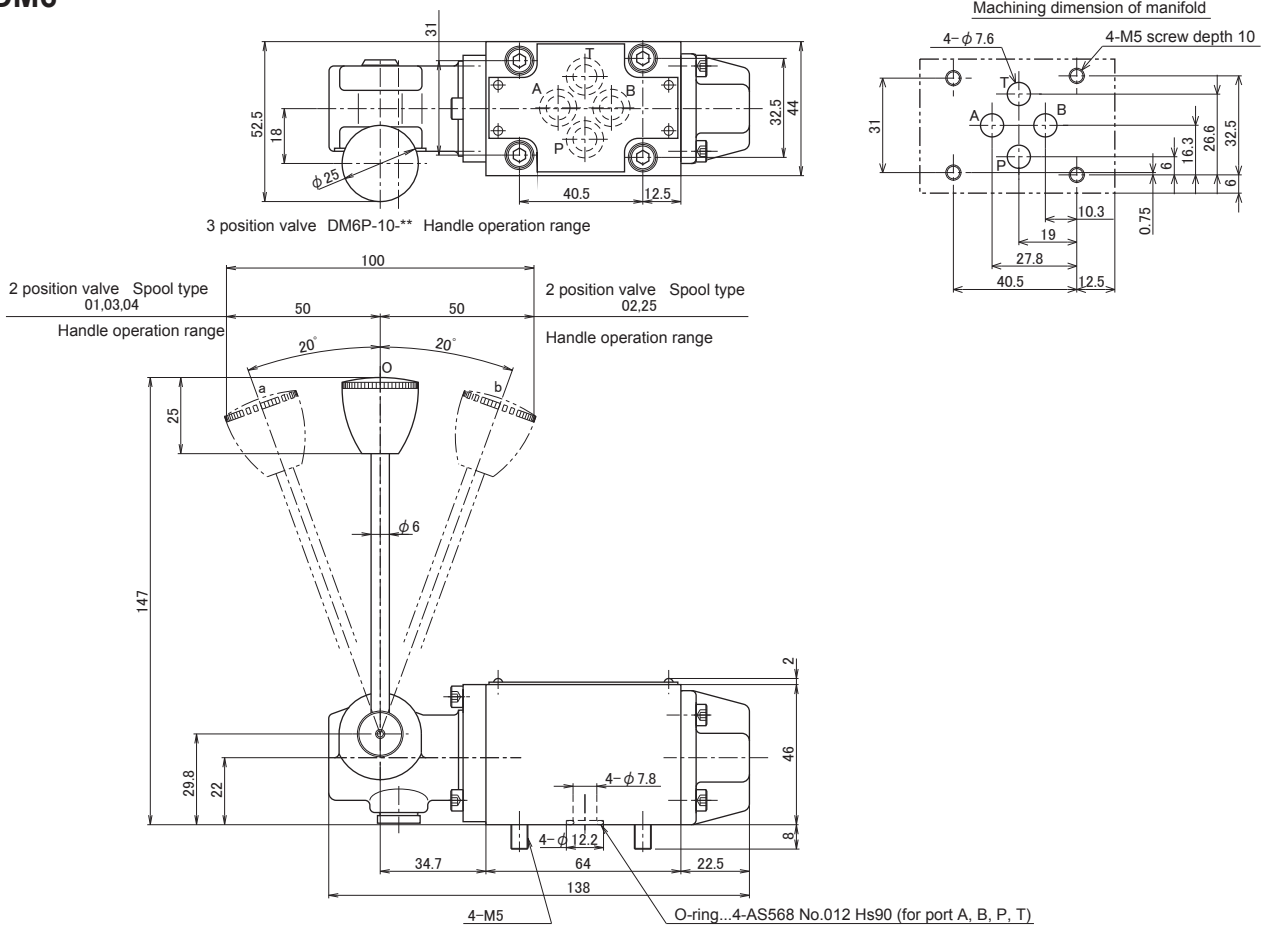

DM10

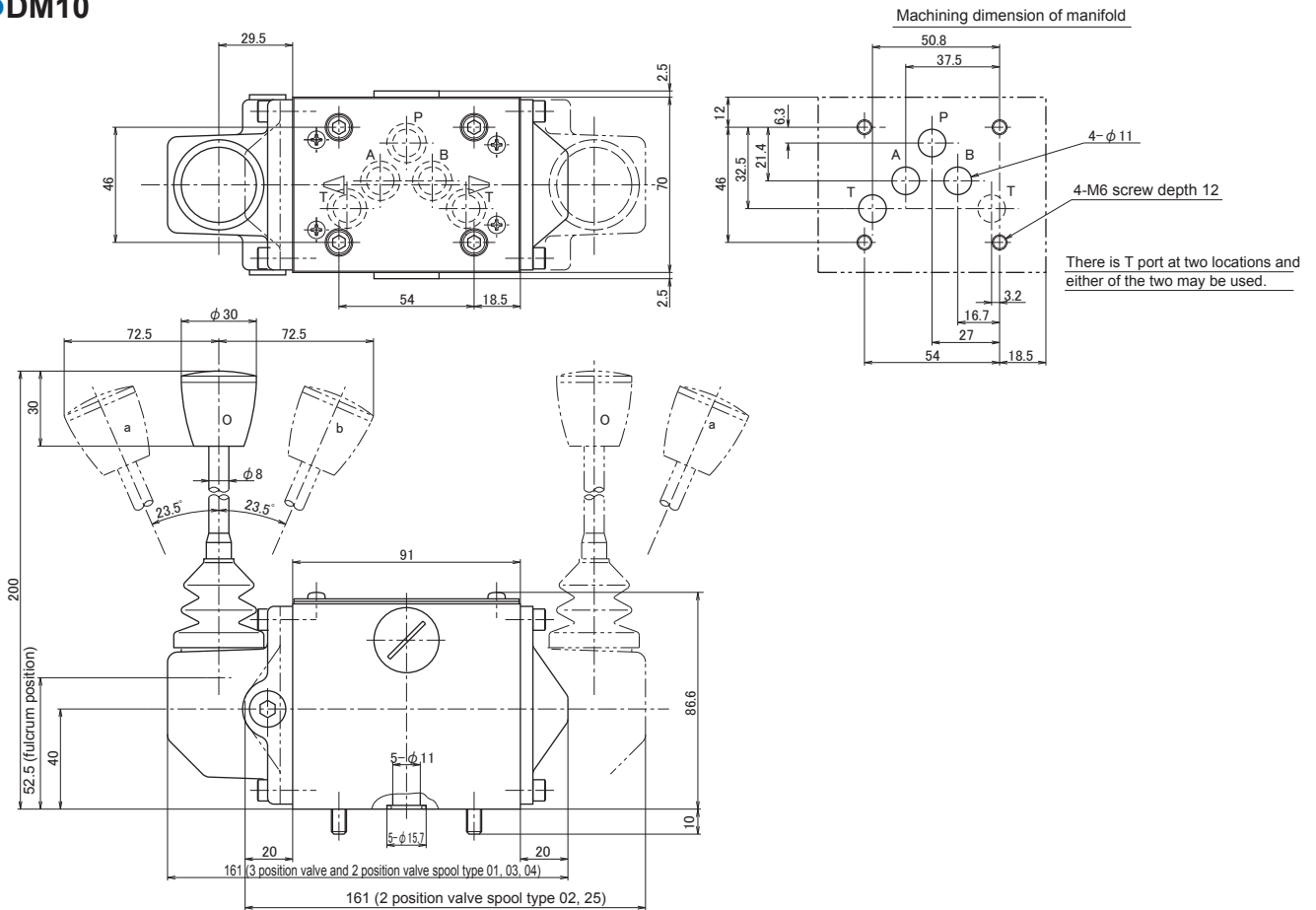

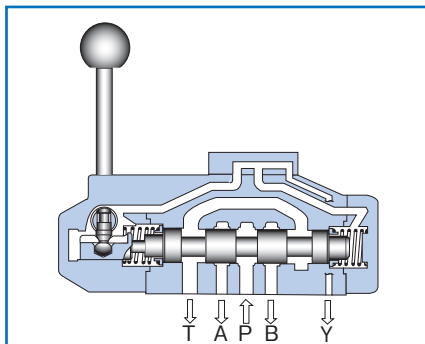
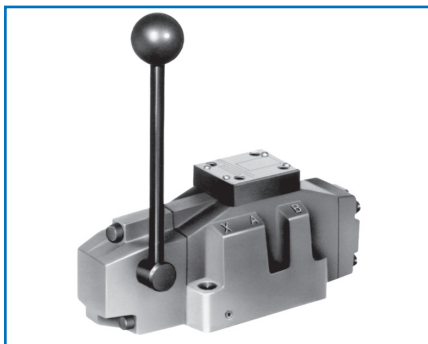

Overview

This manual selector valve is used for controlling start and stop, and movement direction of the hydraulic system with handle operation.

Features

1. The improvement of internal coring shape and spool shape of the casing has substantially reduced the flow resistance.
2. The maximum working pressure is 34.3 MPa (350 kgf/cm²).

Type indication

DM 16 P - 10 - 1 05 T -

Manual selector valve

Nominal dimension
16, 22, 32

Connection method
P = Gasket connection type

Series number: 10

Position holding method
1 = No spring type, detent type
2 = Spring offset type
Spring center type

Spool type
* Refer to "Spool type symbols".

Type of hydraulic oil
No symbol = Mineral based hydraulic oil
V = Phosphate ester based hydraulic oil
W = Fatty ester based hydraulic oil
Water-glycol based hydraulic oil

Drain system
No symbol = External drain
T = Internal drain

Sub-plate

Valve type	Sub-plate type	Connection diameter	Mass
DM16	P-DEH16G34-0	G $\frac{3}{4}$	7.0kg
	P-DEH16R34-0	Rc $\frac{3}{4}$	
	P-DEH16G1-0	G 1	14.5kg
	P-DEH16R1-0	Rc 1	
DM22	P-DEH22G1-0	G 1	11kg
	P-DEH22R1-0	Rc 1	
	P-DEH22G54-0	G $\frac{5}{4}$	24kg
	P-DEH22R54-0	Rc $\frac{5}{4}$	
	P-DEH22G32-0	G $\frac{3}{2}$	
DM32	P-DEH22R32-0	Rc $\frac{3}{2}$	19kg
	P-DEH32G32-0	G $\frac{3}{2}$	
	P-DEH32R32-0	Rc $\frac{3}{2}$	

When you use a sub-plate, please place an order for the above sub-plate type. For the dimension drawing, refer to pages 9, 10 and 11 of the appendix.

Accessories

Mounting bolt

Type	Hexagon socket head cap thread	Quantity	Tightening torque N·m (kgf·cm)
DM16	M6×55L	2 pcs.	11.8± 1.7 (120± 18)
	M10×60L	4 pcs.	56.8± 8.5 (580± 87)
DM22	M12×60L	6 pcs.	98.0±14.7 (1000±150)
DM32	M20×80L	6 pcs.	431.2±64.6 (4400±660)

Spool type symbol

Valve type		Hydraulic symbols	Transient state
Valve type	Spool type		
2 position valve			
	03		
	04		
	11		
	26		
3 position valve			
	05		
	06		
	07		
	08		
	10		
	12		
	13		
	17		
	18		
	19		
	20		
	21		
	22		
	23		

Specifications

Nominal dimension		16	22	32
Maximum working pressure MPa (kgf/cm ²)	Port A, B, P	34.3 (350)		
	Port T	External drain type	24.5 (250)	
		Internal drain	2.9 (30)	
Opening area at spool neutral position (with spool 10 as 100%)	Spool 17, 22	16%		
	Spool 23	3%		
Manual lever operating force N (kgf)	2 position valve spring offset type 3 position valve spring center type	29.4 (3)	39.2 (4)	98.0 (10)
	No spring type with detent	39.2 (4.0)	83.3 (8.5)	98.0 (10)
Mass kg		7.5	13	49

Maximum flow rate

Maximum flow rate L/min							
Nominal dimension	Valve type	Spool type	Working pressure MPa (kgf/cm ²)				
			6.9 (70)	13.7 (140)	20.6 (210)	27.4 (280)	34.3 (350)
16	Spring offset type Spring center type	05, 10, 12, 13, 17, 18, 21 22, 23, 03, 04, 11, 26	180	180	180	180	170
		06	125	100	80	70	65
		07, 08, 19, 20	125	115	90	80	70
	No spring type with detent	All spools	180	180	180	180	180
22	Spring offset type Spring center type	05, 10, 12, 13, 17, 18, 21 22, 23	450	450	370	320	300
		06, 07, 08, 19, 20, 03, 04 11, 26	265	190	155	135	120
	No spring type with detent	All spools	450	450	370	320	300
32	Spring offset type Spring center type	05, 10, 12, 13, 17, 18, 21 22, 23	1100	1050	860	750	680
		06, 07, 08, 19, 20, 03, 04 11, 26	650	450	370	320	280
	No spring type with detent	All spools	1100	1050	860	750	680

Pressure drop characteristics

- Similar to those of solenoid controlled pilot operated directional valve (1) (DEH16, 22, 32). Refer to the section of the type number index "DEH16, 22, 32".

Dimension drawing

DM16

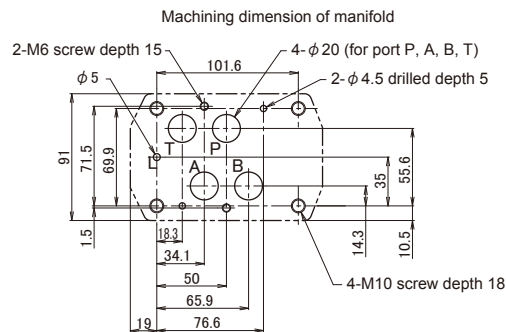
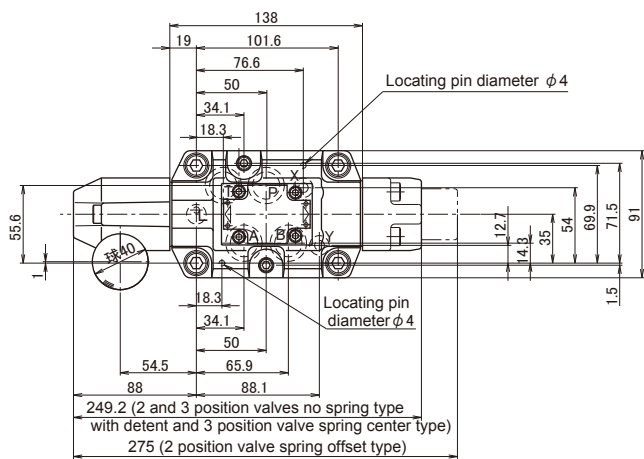

(Note) Ports X and Y are not used.
Use port L in the case of external drain type.

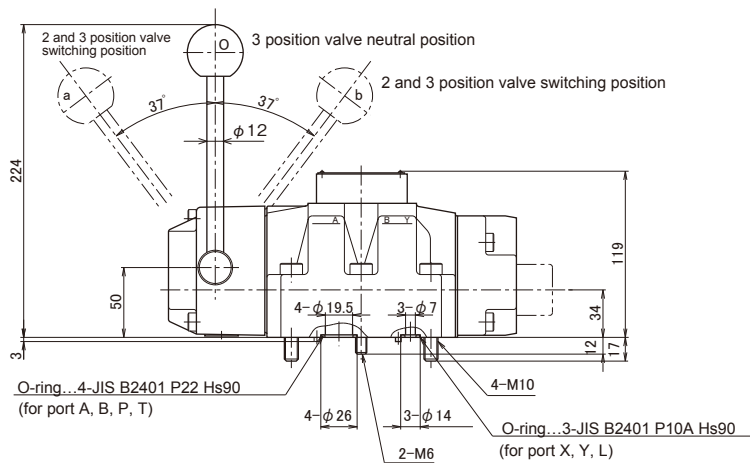

DM22

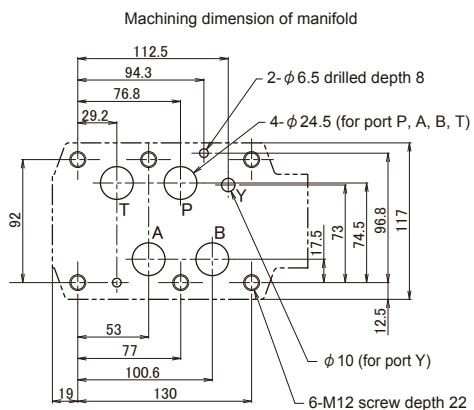
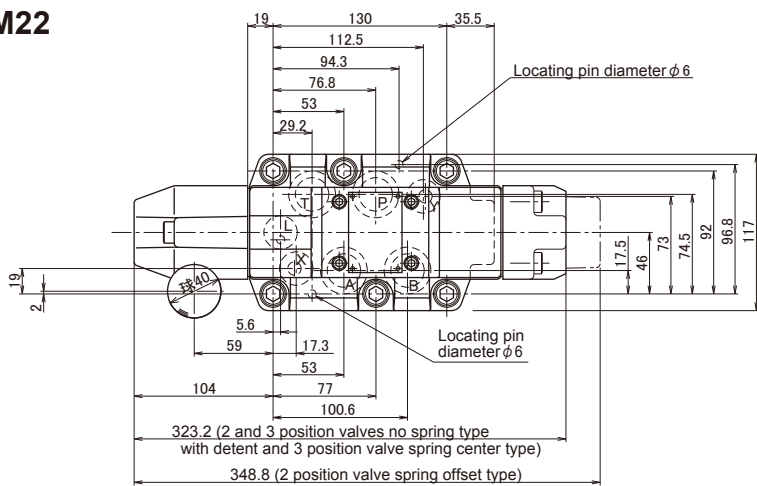

(Note) Ports X and L are not used.
Use port Y in the case of external drain type.

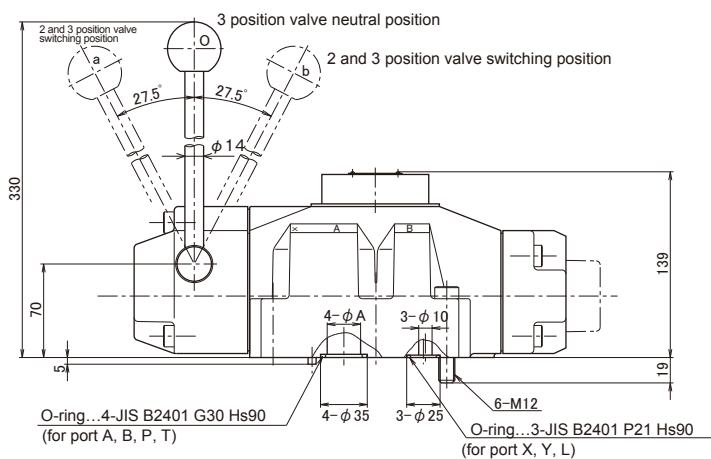

Dimension	ϕA
Port P	24
Port A, B	24.5
Port T	25

DM32

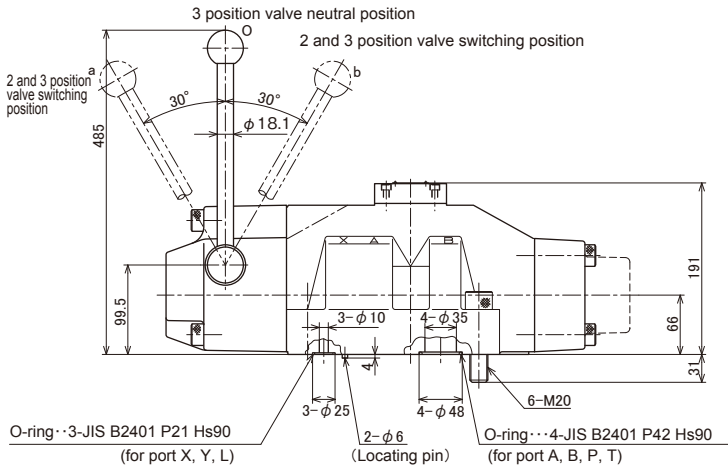
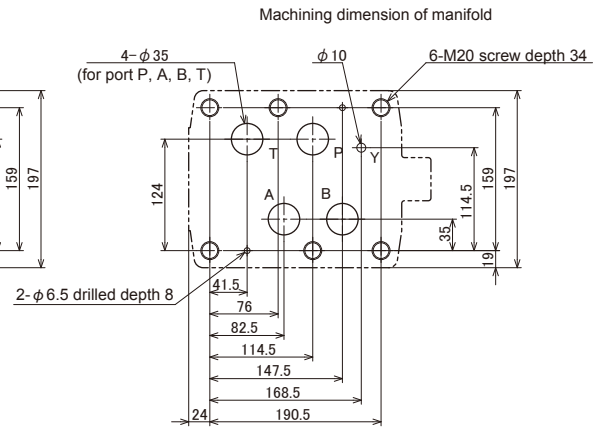
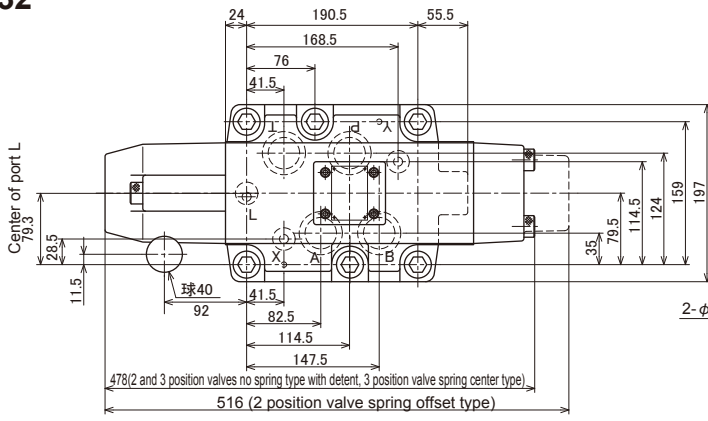

(Note) Ports X and L are not used.
Use port Y in the case of external drain type.

Manual selector valve – K4LA type

K4LA

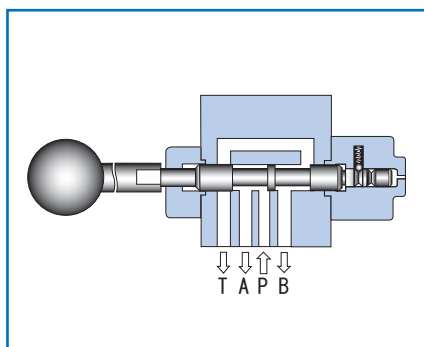
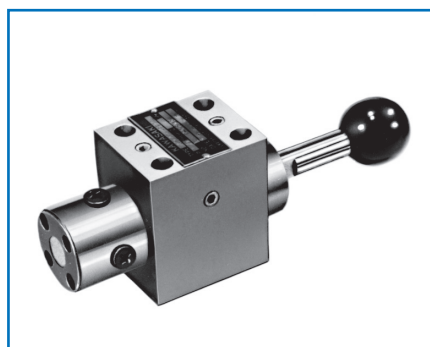

Hydraulic symbols

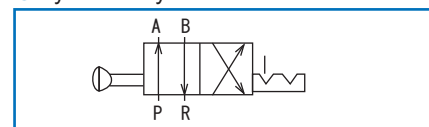

Overview

This manual selector valve is used for controlling start and stop, and movement direction of the hydraulic system with handle operation.

Specifications

Nominal dimension		6
Maximum working pressure MPa (kgf/cm ²)	Port A, B, P	24.5 (250)
	Port R	2.9 (30)
Maximum flow rate L/min		20
Mass kg		1.9

Type indication

K4LAR 6 EP - 2C - 10 - []

Manual selector valve with 4 port detent

Nominal dimension: 6

Connection method
EP = Gasket connection type

Type of hydraulic oil
 Mineral based hydraulic oil
 No symbol = Mineral based hydraulic oil
 V = Phosphate ester based hydraulic oil
 W = Fatty ester based hydraulic oil
 Water-glycol based hydraulic oil

Series number: 10

Spool type: 2C

Sub-plate

Valve type	Sub-plate type	Connection diameter	Mass
K4LA	P-DE6R14-0	Rc 1/4	1.0kg
	P-DE6G14-0	G 1/4	
	P-DE6R38-0	Rc 3/8	2.2kg
	P-DE6G38-0	G 3/8	

When you use a sub-plate, please place an order for the above sub-plate type.

For the dimension drawing, refer to page 11 of the appendix.

Accessories

Mounting bolt

Type	Hexagon socket head cap thread	Quantity	Tightening torque N·m (kgf·cm)
K4LAR6EP	M5 × 75L	4 pcs.	6.9 ± 1.0 (70 ± 10.5)

Dimension drawing

K4LAR6

Switching position	When pressed in	When pulled out
L	2mm	8mm

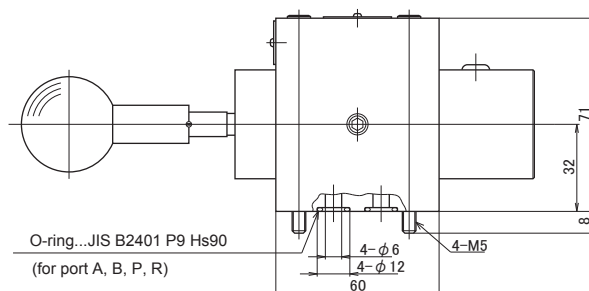
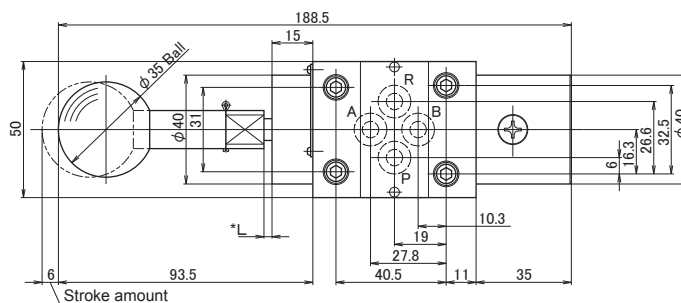

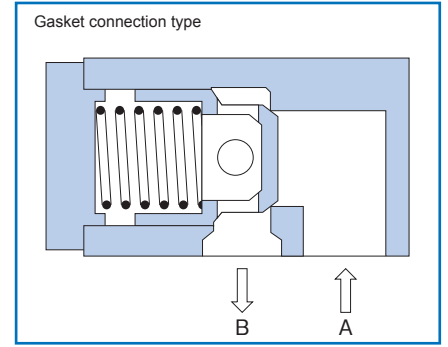
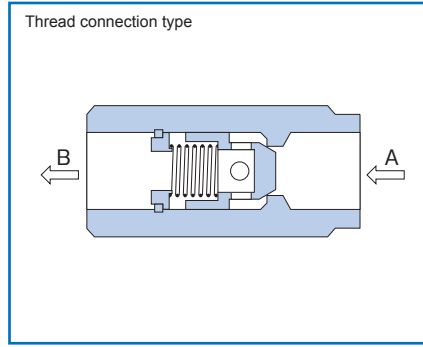

Overview

This check valve is used for allowing the flow from one direction to pass freely according to the cracking pressure of the valve and for blocking the flow from the opposite direction.

Features

1. There are an in-line type that has thread connection system and a right angle type that has gasket connection system.
2. There are six types of cracking pressure with no spring: 0.01, 0.05, 0.15, 0.29 and 0.39 MPa.
3. Cartridge type elements are also manufactured.

Hydraulic symbols

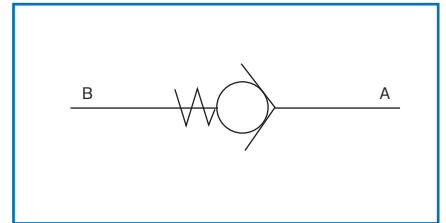

Type indication

● C

C6R - 10 - 05 - []

Check valve	_____	Type of hydraulic oil	_____
Nominal dimension	_____	(Specify only in the case of gasket connection type.)	
6, 8, 10, 15, 20, 25, 30		No symbol = Mineral based hydraulic oil	
(Gasket connection type is 10, 20 and 30 only.)		V = Phosphate ester based hydraulic oil	
Connection method	_____	W = Fatty ester based hydraulic oil	
G = G thread connection type		Water-glycol based hydraulic oil	
GO = G thread connection type (based on JIS B2351 0 type)		(Note) It is not necessary to enter the type of hydraulic oil when the connection method is other than "P".	
R = R thread connection type		Cracking pressure	_____
P = Gasket connection type		00 = No spring	
C = Cartridge type (for in-line)		(There is no no-spring type in the case of cartridge type.)	
Series number: 10	_____	01=0.01MPa(0.1kgf/cm ²)	
		05=0.05MPa(0.5kgf/cm ²)	
		15=0.15MPa(1.5kgf/cm ²)	
		30=0.29MPa(3.0kgf/cm ²)	
		40=0.39MPa(4.0kgf/cm ²)	

● C1M

C1M6C - 10 - 05 - []

Cartridge type check valve for angle	_____	Type of hydraulic oil	_____
Nominal dimension	_____	No symbol = Mineral based hydraulic oil	
6, 8, 10, 15, 20, 25, 30		Phosphate ester based hydraulic oil	
Connection method	_____	Fatty ester based hydraulic oil	
C = Cartridge type		Water-glycol based hydraulic oil	
Series number: 10	_____	Cracking pressure	_____
		01=0.01MPa(0.1kgf/cm ²)	
		05=0.05MPa(0.5kgf/cm ²)	
		15=0.15MPa(1.5kgf/cm ²)	
		30=0.29MPa(3.0kgf/cm ²)	
		40=0.39MPa(4.0kgf/cm ²)	

Specifications

Nominal dimension		6	8	10	15	20	25	30
Maximum specification pressure MPa (kgf/cm ²)		30.9 (315)						
Maximum flow rate L/min		15	35	50	120	200	300	400
Mass kg	Thread connection type	0.1	0.2	0.5	0.7	1.2	2.3	2.3
	Gasket connection type	—	—	1.4	—	4	—	12
	Cartridge	0.05	0.05	0.05	0.1	0.2	0.25	0.3

Accessories

Mounting bolt

Type	Hexagon socket head cap thread	Quantity	Tightening torque N·m (kgf·cm)
C10P	M8 × 50L	4 pcs.	29.4 ± 4.4 (300 ± 45.0)
C20P	M10 × 70L	4 pcs.	56.8 ± 8.5 (580 ± 87.0)
C30P	M16 × 90L	4 pcs.	235.2 ± 35.3 (2400 ± 360.0)

Pressure drop characteristics (viscosity 36 mm²/s (cSt))

When cracking pressure is 0.05 MPa

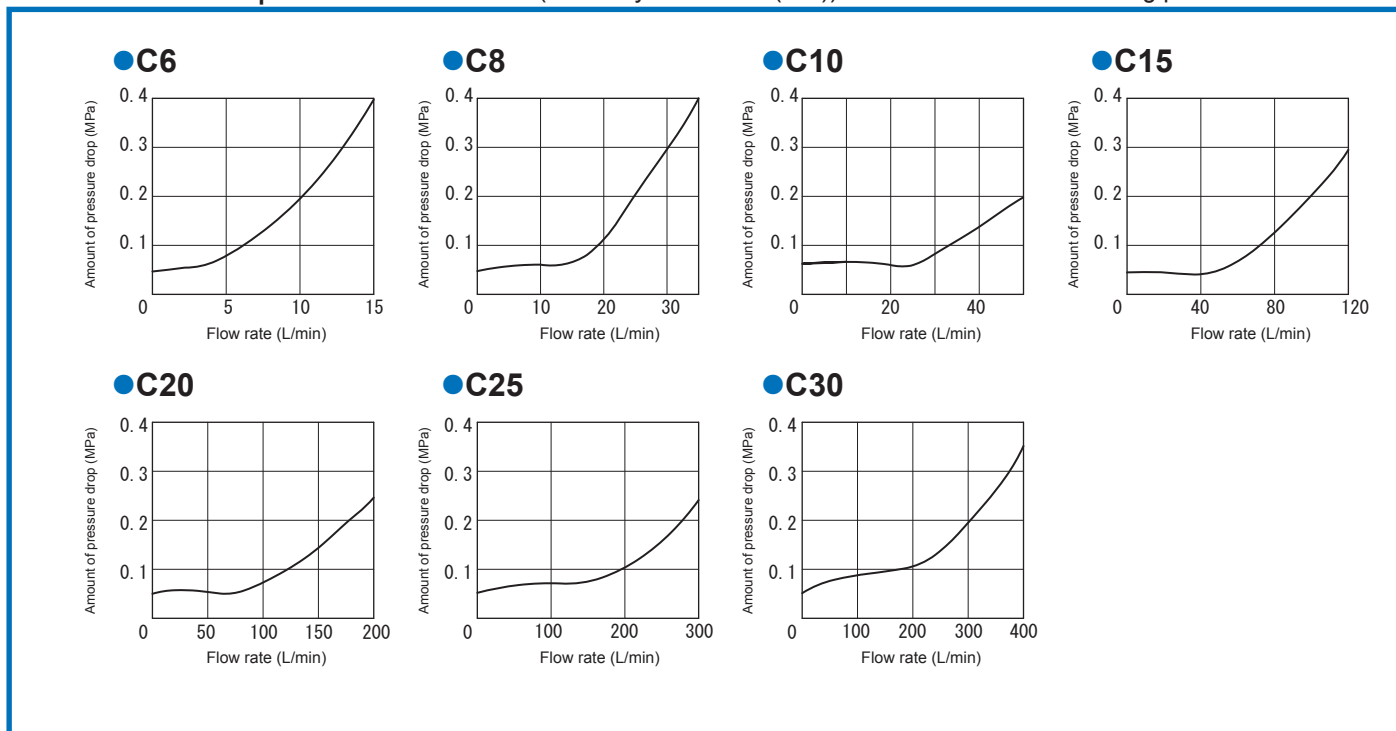

Dimension drawing

●C (screw connection type)

Nominal dimension		A	B	C	D	E
6	G	58	24	27.7	G $\frac{1}{4}$	12
	R				Rc $\frac{1}{4}$	9
8	G	58	32	37	G $\frac{3}{8}$	12
	R				Rc $\frac{3}{8}$	10
10	G	72	36	41.6	G $\frac{1}{2}$	14
	R				Rc $\frac{1}{2}$	12
15	G	85	41	47.3	G $\frac{3}{4}$	16
	R				Rc $\frac{3}{4}$	14
20	G	98	50	57.7	G 1	18
	R				Rc 1	16
25	G	120	63	72.7	G 1 $\frac{1}{4}$	23
	R				Rc 1 $\frac{1}{4}$	18
30	G	132	63	72.7	G 1 $\frac{1}{2}$	23
	R				Rc 1 $\frac{1}{2}$	18

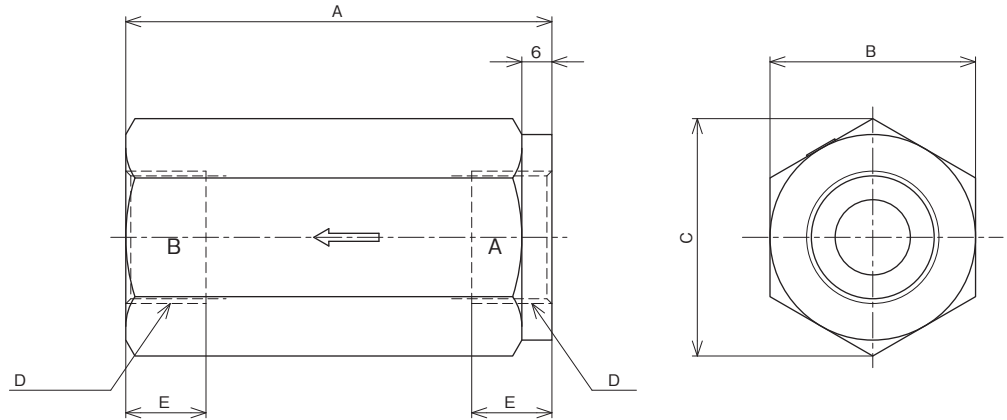

(Note)
 1. When using the no spring type, be sure to install it so that port B faces upward.
 2. Articles of screw connection type are undisassemblable.

●C (gasket connection type)

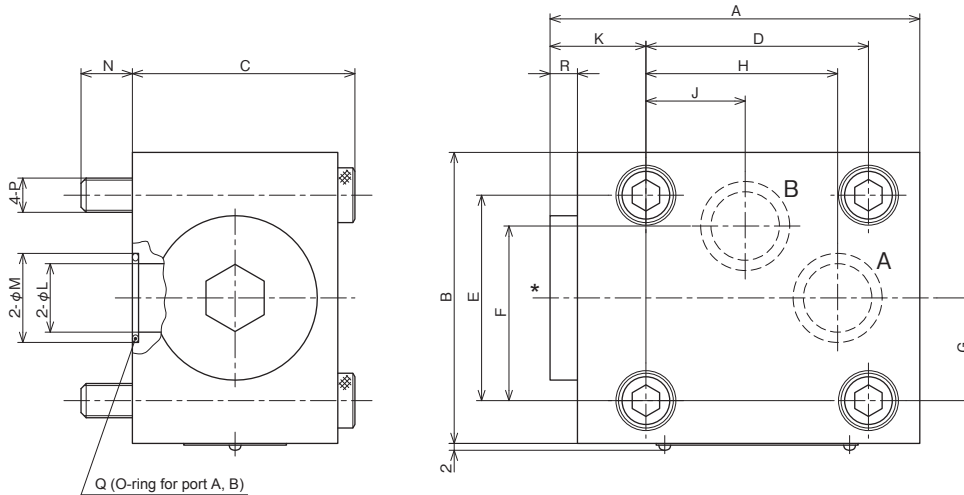

Nominal dimension	A	B	C	D	E	F	G	H	J	K	L	M	N	P	R	"Q" O-ring dimension
10	75	60	46	40	40	32	20	36	18	20	10	16	12	M8	5	2-JIS B 2401 P12 Hs90
20	108	85	65	65	60	51	30	56	29	28	20	26	15	M10	8	2-JIS B 2401 P22 Hs90
30	145	130	83	95	100	83	50	85	45	30	30	40	24	M16	5	2-JIS B 2401 G35 Hs90

(Note) When using the no spring type, be sure to install it so that the surface marked with * faces upward.

●C (cartridge type for in-line)

Valve type	L1	L2	L3	L4	L5	D1 H7	D2	D3 H8
C6C-10-	01	29.3	21.3	18	3.5	10	6	10.5
	05				9			
	15				8.5			
	30				8.5			
40	3	8.5						
C8C-10-	01	32.8	22.8	19	4	13	8	14
	05				9.5			
	15				9.5			
	30				9.5			
40	3	9.5						
C10C-10-	01	38.8	28.8	21	4	17	10	17.5
	05				11.5			
	15				10.5			
	30				10.5			
40	3	10.5						
C15C-10-	01	49	37	27	5.5	22	15	23
	05				15			
	15				15			
	30				15			
40	4	15						
C20C-10-	01	59.6	44.6	29	5.5	28	20	29
	05				16.5			
	15				17.5			
	30				17.5			
40	4	17.5						
C25C-10-	01	72.9	54.9	38	7	36	25	37.5
	05				24.5			
	15				23			
	30				23			
40	5.5	23						
C30C-10-	01	83.6	63.6	42	7.5	42	30	43
	05				25.5			
	15				25.5			
	30				25.5			
40	5.5	25.5						

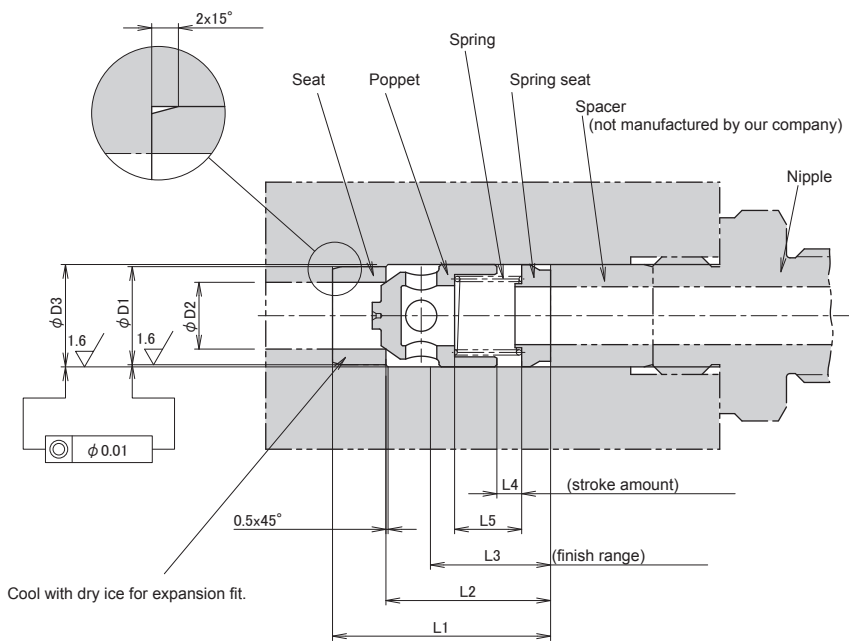

●C (cartridge type for angle)

Valve type	L1	L2	L3	L4	L5	L6	L7	D1 H7	D2	D3 H8	D4
C1M6C-10-	28.1	20.1	16.1	11	3.5	9	11.3	10	6	11	6
					9						
					8.5						
					10.8						
40	3	8.5	10.8								
C1M8C-10-	36.5	26.5	21.5	16	4	9.5	12.4	13	8	14	8
					9.5						
					9.5						
					12.4						
40	3	9.5	12.4								
C1M10C-10-	39.5	29.5	23.5	17	4	11.5	14.8	17	10	18	10
					11.5						
					10.5						
					13.8						
40	3	10.5	13.8								
C1M15C-10-	46.5	34.5	26	18	5.5	15	18.5	22	15	24	15
					15						
					15						
					18.5						
40	4	15	18.5								
C1M20C-10-	55.9	40.9	30.4	23	5.5	16.5	21.3	28	20	30	20
					16.5						
					17.5						
					22.3						
40	4	17.5	22.3								
C1M25C-10-	74.3	56.3	41.8	31	7	24.5	30	36	25	38	25
					24.5						
					23						
					28.5						
40	5.5	23	28.5								
C1M30C-10-	84.1	64.1	48.1	37	7.5	25.5	31.1	42	30	44	30
					25.5						
					25.5						
					31.1						
40	5.5	25.5	31.1								

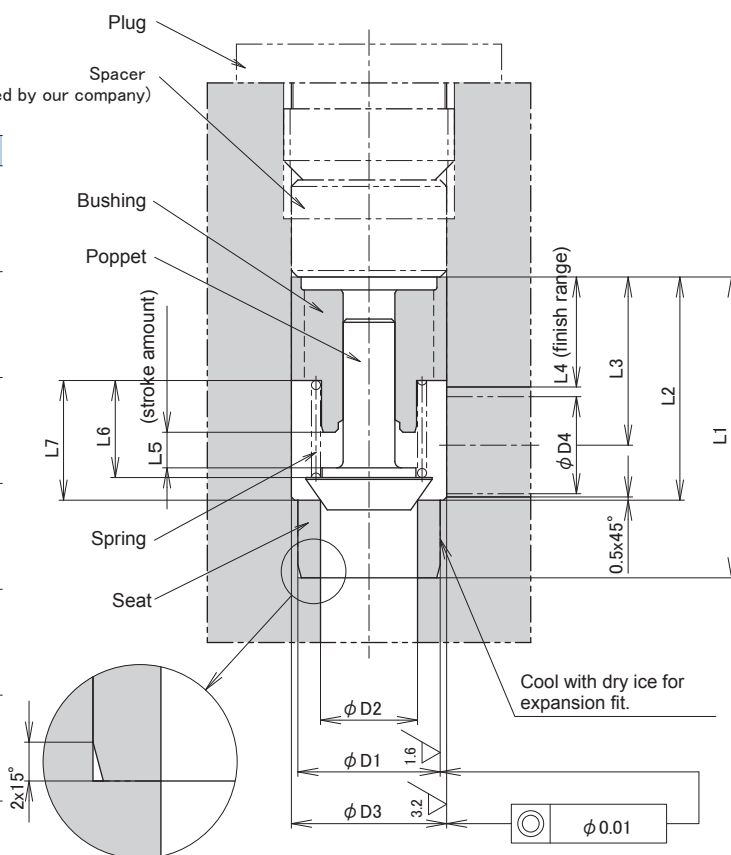

Overview

This check valve is used for allowing the flow from one direction to pass freely according to the cracking pressure of the valve and for blocking the flow from the opposite direction.

Features

1. There are an in-line type that has flange connection system and a right angle type that has gasket connection system.
2. There are six types of cracking pressure with no spring: 0.01, 0.05, 0.15, 0.29 and 0.39 MPa.
3. Cartridge type elements are also manufactured.

Type indication

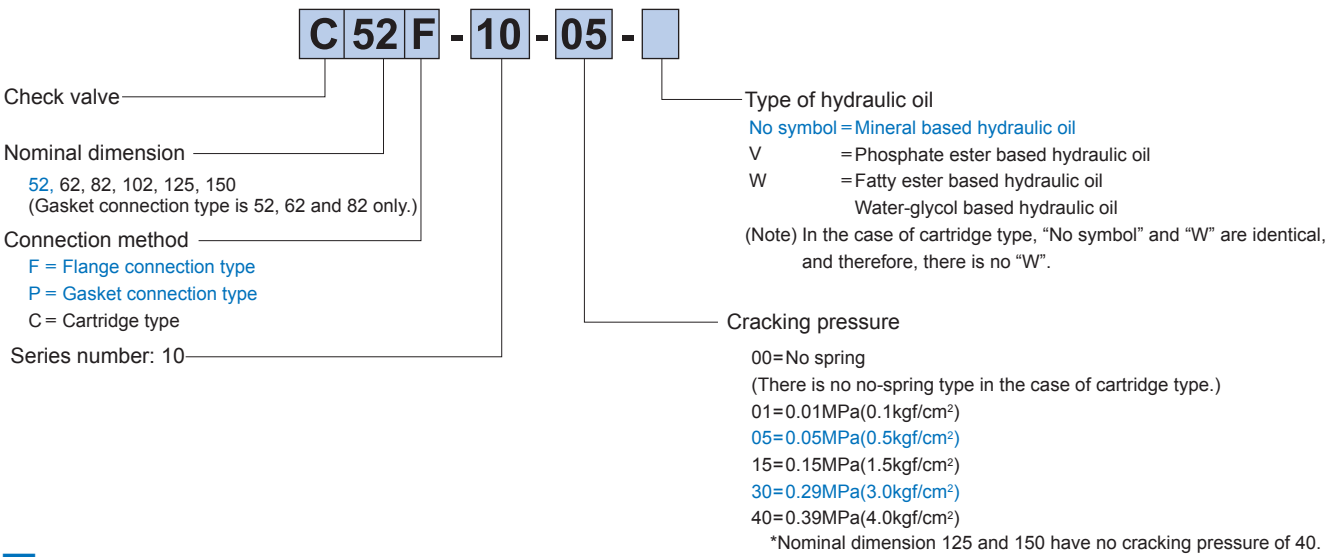

Flange

Valve type	Maximum working pressure	Flange type	Connection diameter	Mass
C52F	20.6MPa	TFAA-40	2B	2.6kg
	30.9MPa	TFXA-40	2B	2.7kg
C62F	20.6MPa	TFAA-50	2½ B	3.9kg
	30.9MPa	TFXA-50	2½ B	4.5kg
C82F	20.6MPa	TFAA-63	3B	7.9kg
	30.9MPa	TFXA-63	3B	8.5kg
C102F	20.6MPa	TFAA-80	4B	13 kg
	30.9MPa	TFXA-80	4B	14 kg
C125F	20.6MPa	TFAA-125	6B	42 kg
	30.9MPa	TFXA-125	6B	45 kg
C150F	20.6MPa	TFAA-150	8B	70 kg
	30.9MPa	TFXA-150	8B	75 kg

When you use a flange, please place an order for the above flange type.
For the dimension drawing, refer to page 16 of the appendix.

Accessories

Specifications

Type	Hexagon socket head cap thread	Quantity	Tightening torque N·m (kgf·cm)
C52P	M16 × 110L	6 pcs.	235.2 ± 35.3 (2400 ± 360.0)
C62P	M20 × 135L	6 pcs.	431.2 ± 64.7 (4400 ± 660.0)
C82P	M20 × 165L	6 pcs.	

Specifications

Nominal dimension	52	62	82	102	125	150	
Maximum working pressure MPa (kgf/cm ²)	30.9 (315)						
Maximum flow rate L/min	700	1100	1800	3000	4400	6400	
Mass kg	Flange connection type	10.6	15	27.5	50	190	330
	Gasket connection type	17	31.5	57	—	—	—
	Cartridge type	1.9	3.3	5.6	9.4	36.2	76.1

Pressure drop characteristics (viscosity 36 mm²/s (cSt))

When cracking pressure is 0.05 MPa

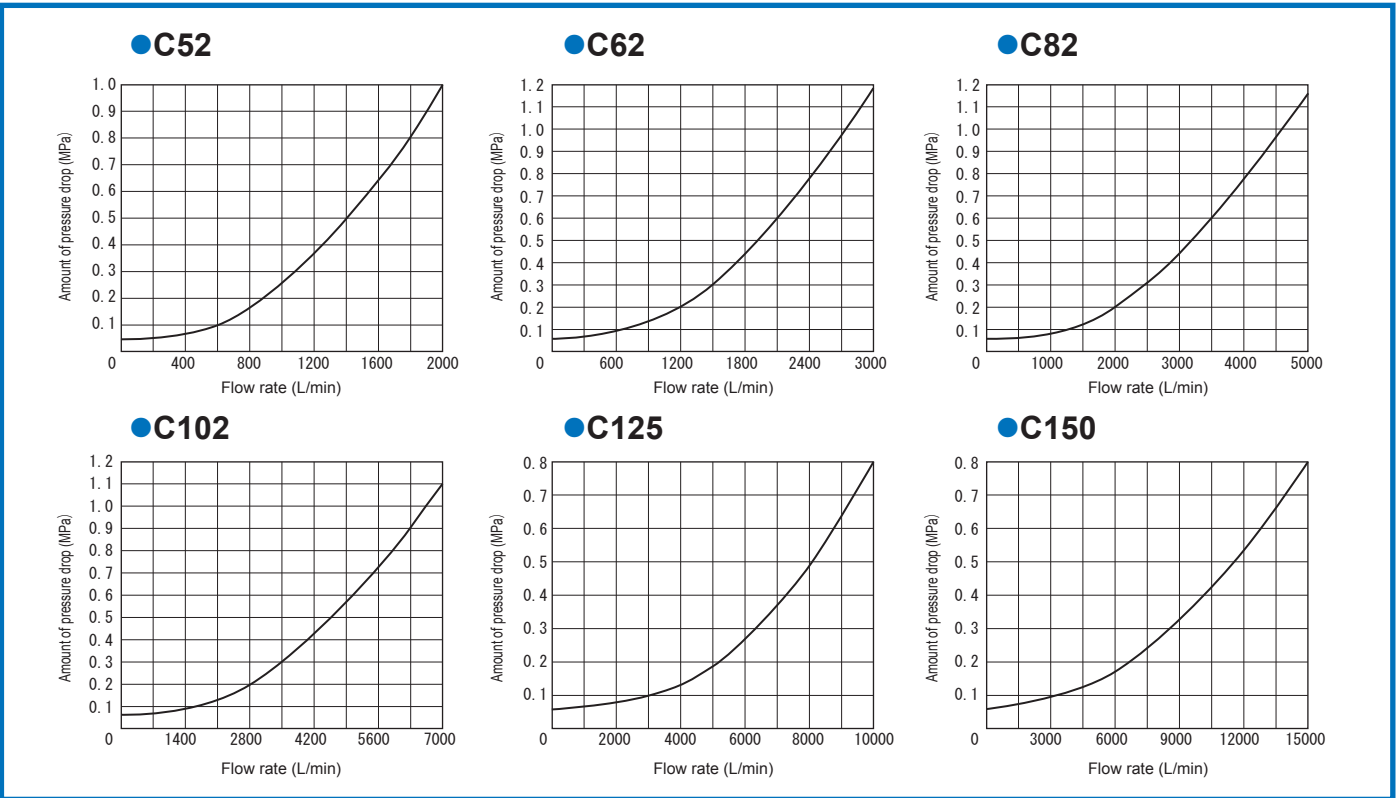

Dimension drawing

●C (gasket connection type)

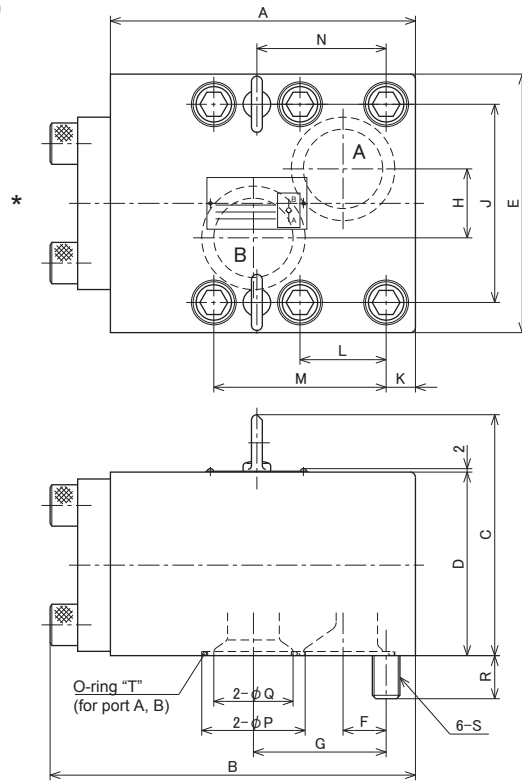

Nominal dimension	A	B	C	D	E	F	G	H	J	K	L	M	N	P	Q	R	S	O-ring dimension "T"
52	177	212	140.5	106.5	150	25	77	40	115	17	50	100	75	60	50	25	M16	2-JIS B2401 G55 Hs90
62	224	266.5	160.5	126.5	180	34	100	40	140	21.5	65	128	96	70	60	30	M20	2-JIS B2401 G65 Hs90
82	275	325	190.5	156.5	210	30	115	50	170	35	70	140	105	90	80	30	M20	2-JIS B2401 G85 Hs90

Note) When using the no spring type, be sure to install it so that the surface marked with * faces upward.

●C (flange connection type)

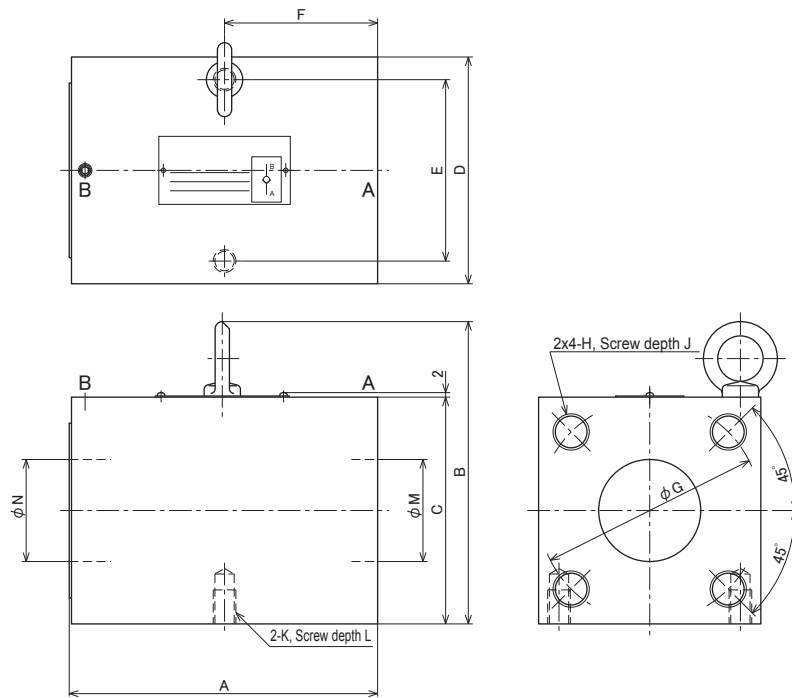

Nominal dimension	A	B	C	D	E	F	G	H	J	K	L	M	N
52	135.5	132	98	100	80	67.5	98	M16	26	M10	15	45	45
62	165.5	152	118	120	100	82.5	118	M20	32	M10	15	53	53
82	195.5	182	148	150	120	97.5	145	M24	36	M12	20	70	65
102	245.5	220	178	180	150	122.5	175	M30	40	M12	20	86.5	86.5

Note) When using the no spring type, be sure to install it so that port B faces upward.

● C (flange connection type)

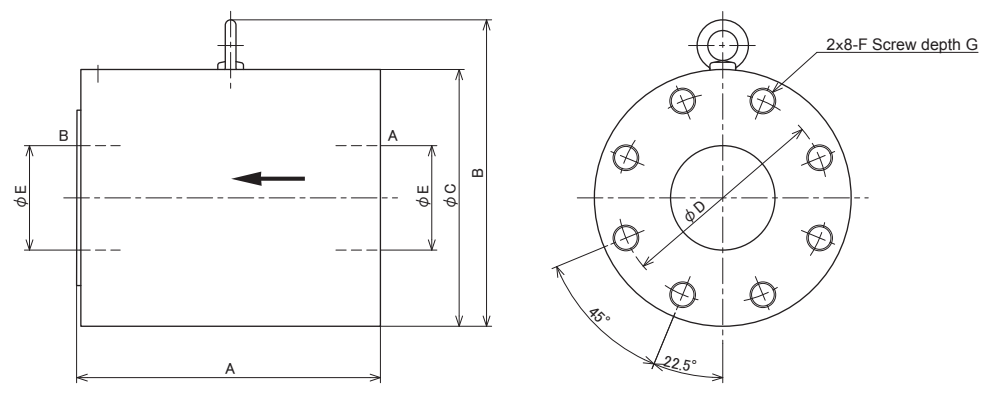

Nominal dimension	A	B	C	D	E	F	G
125	350.5	360	300	245	122	M30	50
150	501	431	360	290	150	M36	60

Note) When using the no spring type, be sure to install it so that port B faces upward.

● C (large diameter) - cartridge type

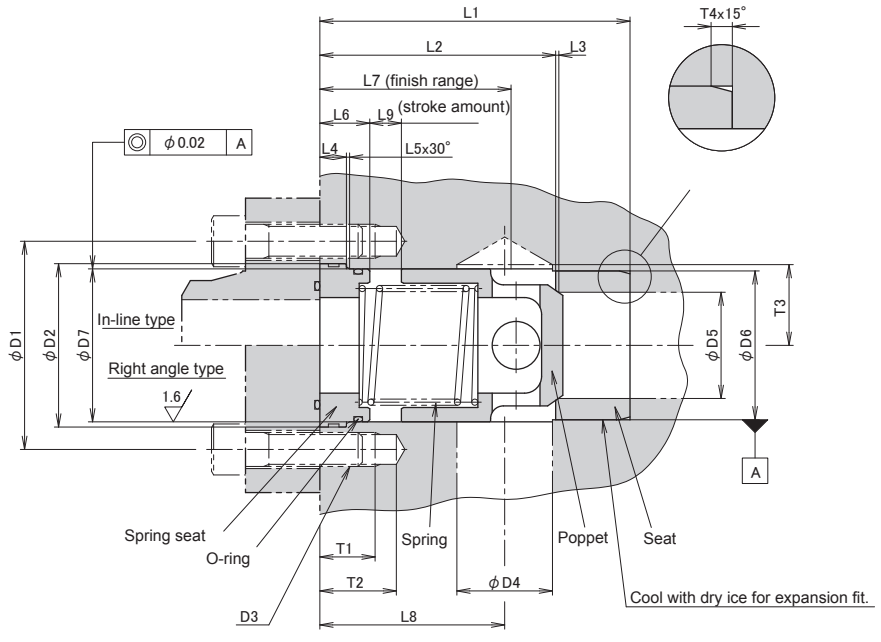

Valve type	L1	L2	L3	L4	L5	L6	L7	L8	L9	D1±0.2	D2 ^{0.1}	D3	D4	D5 ^{H7}	D6 ^{H7}	D7 ^{H8}	T1	T2	T3	T4	
C52 C- 10-	01	146	111	1.5	12	1.5	23	90	87	15	98	77	4-M16	45	50	70	72	26	36	38	5
	05																				
	15*																				
	30																				
40																					
C62 C- 10-	01	175	135	1.5	12	1.5	24.5	110	106	17.5	118	93	4-M20	55	63	85	86	32	42	45	5
	05																				
	15*																				
	30																				
40																					
C82 C- 10-	01	210	165	1.5	15	2	29	135	128	25	145	115	4-M24	72	72	100	106	36	50	55	5
	05																				
	15*																				
	30																				
40																					
C102 C- 10-	01	260	210	2	18	2	31.5	160	164	28	175	140	4-M30	90	90	125	132	40	55	68	6
	05																				
	15*																				
	30																				
40																					
C125 C- 10-	01	360	295	3	30	2.5	51.5	230	233	34.5	245	205	8-M30	122	122	180	190	50	65	98	6
	05*																				
15																					
C150 C- 10-	01	510	430	5	32	2.5	81.5	320	354	38.3	290	240	8-M36	150	150	220	230	60	75	118	6
	05*																				
15																					

(Note) When used for in-line, a hole of φ D4 is not necessary.

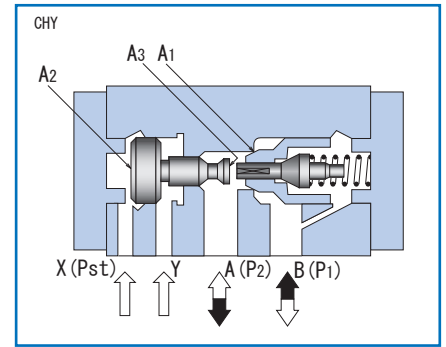
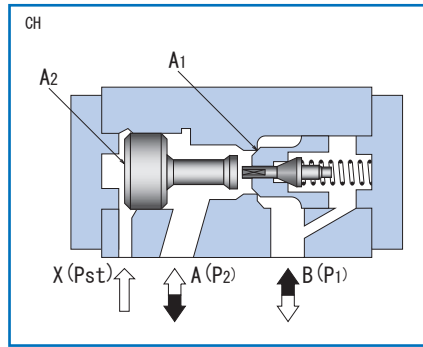
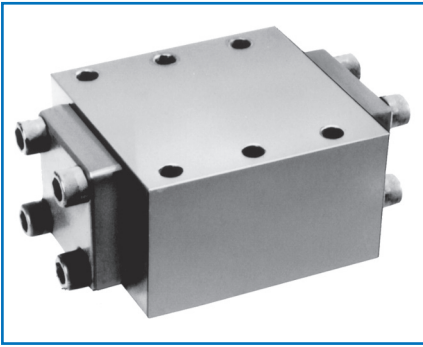

Overview

This pilot check valve operates the pilot using remote pressure and allows for back flow as appropriate. This valve is mainly used in a press or lift to prevent load from falling due to leakage of the hydraulic circuit.

Features

This is of decompression type. As the main valve opens after the pilot valve opens, smooth switching without shocks can be performed under high pressure and large capacity.

Hydraulic symbols

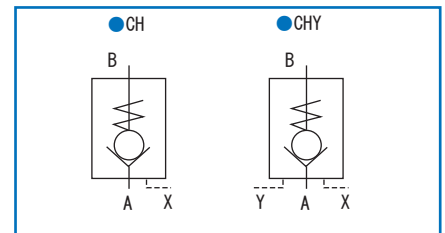

Type indication

CH 10 R - 10 - 14 -

Pilot operated check valve

Drain system

- No symbol = Internal drain
- Y = External drain

Nominal dimension

- 6, 8, 10, 15, 20, 25, 30
- (Gasket connection type is 10, 20 and 30 only.)

Connection method

- G = G thread connection type
- GO = G thread connection type (based on JIS B2351 0 type)
- R = R thread connection type
- P = Gasket connection type

Type of hydraulic oil

- No symbol = Mineral based hydraulic oil
- V = Phosphate ester based hydraulic oil
- W = Fatty ester based hydraulic oil
- Water-glycol based hydraulic oil

Cracking pressure

Symbol	Cracking pressure	Nominal dimension
10	0.10MPa	15, 20, 25, 30
14	0.14MPa	6, 8, 10

Series number: 10

Specifications

Nominal dimension	CH							CHY						
	6	8	10	15	20	25	30	6	8	10	15	20	25	30
Maximum working pressure MPa (kgf/cm ²)	30.9 (315)							30.9 (315)						
Maximum flow rate L/min	80		170		300			80		170		300<170> (Note)		
Maximum pilot pressure MPa (kgf/cm ²)	30.9 (315)							30.9 (315)						
Pilot volume cm ³	Port X		2.2		8.7		17.5			2.2		17.5<8.7>		
	Port Y		—		—			1.9		15.8<7.6>				
Mass kg	2.5		4		8			2.5		8<6.5>				

(Note) Values are those inside < > only for CHY20P type.

Sub-plate

Valve type	Sub-plate type	Connection diameter	Mass
CH/CHY10P	P-CHY10R14-0	Rc $\frac{1}{4}$	2.1kg
	P-CHY10G14-0	G $\frac{1}{4}$	
	P-CHY10R38-0	Rc $\frac{3}{8}$	
	P-CHY10G38-0	G $\frac{3}{8}$	
	P-CHY10R12-0	Rc $\frac{1}{2}$	
CH/CHY20P	P-CHY20R34-0	Rc $\frac{3}{4}$	4.4kg
	P-CHY20G34-0	G $\frac{3}{4}$	
	P-CHY20R 1-0	Rc 1	
	P-CHY20G 1-0	G 1	
CH/CHY30P	P-CHY30R54-0	Rc $1\frac{1}{4}$	6.9kg
	P-CHY30G54-0	G $1\frac{1}{4}$	
	P-CHY30R32-0	Rc $1\frac{1}{2}$	
	P-CHY30G32-0	G $1\frac{1}{2}$	

When you use a sub-plate, please place an order for the above sub-plate type.
For the dimension drawing, refer to pages 6 and 7 of the appendix.

Accessories

● Mounting bolt

Type	Hexagon socket head cap thread	Quantity	Tightening torque N·m (kgf·cm)
CH/CHY10P	M10×55L	4 pcs.	56.8± 8.5 (580± 87.0)
CH/CHY20P	M10×75L	4 pcs.	
CH/CHY30P	M10×90L	6 pcs.	

Pressure drop characteristics (viscosity 36 mm²/s (cSt))

● CH/CHY6, 8, 10

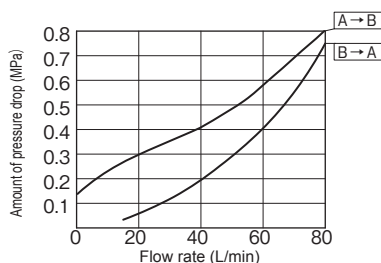

● CH15, 20, CHY15 CHY20P

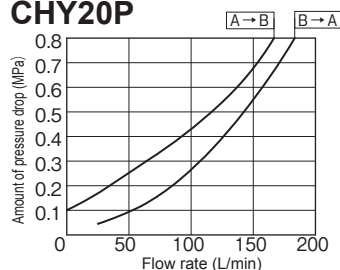

● CHY25, 30, CHY20G(R) CH25, 30

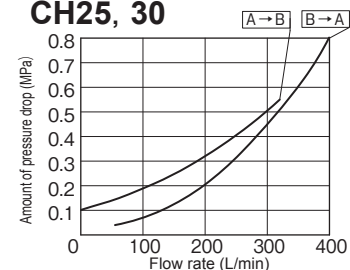

Precautions in use

● Method of obtaining minimum required pilot pressure (refer to symbols in the structural drawing)

In the case of CH

$$P_{st} = P_1 \times \frac{A_1}{A_2} + 0.5\text{MPa} \quad (P_2=0)$$

In the case of CHY

$$P_{st} = \frac{P_1 \times A_1 - P_2 \times (A_1 - A_3)}{A_2} + 0.5\text{MPa}$$

Pst: Minimum required pilot pressure (MPa)

P1: Load pressure (pressure of port B) (MPa)

P2: Back pressure (pressure of port A) (MPa)

A1: Pressure receiving area of poppet (cm²)

A2: Pressure receiving area of lifting piston (cm²)

A3: Pressure receiving area of lifting piston rod (cm²)

Nominal dimension	A1	A2	A3
CH/CHY6, 8, 10	1.13	3.14	0.5
CH15, 20	3.14	9.64	—
CHY20P	3.14	9.64	1.13
CHY15, 20G(R), CH/CHY25, 30	5.30	15.90	1.54

(Note) For minimum required pilot pressure (Pst), low pilot operated check valves for pilot pressure lower than Pst obtained from the above (pilot pressure equivalent to approximately 1/8 of load pressure) are also available (KSV/KSL type). If you need the above valve, please contact us.

● Method of using internal drain type and external drain type

When port A is directly connected to the tank during reverse free flow, the internal drain type is generally used. However, if back pressure is applied to port A, be sure to use the external drain type.

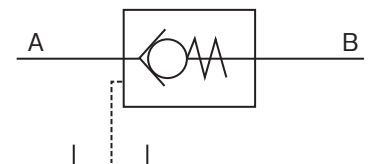

Dimension drawing

●CH/CHY (G screw connection type)

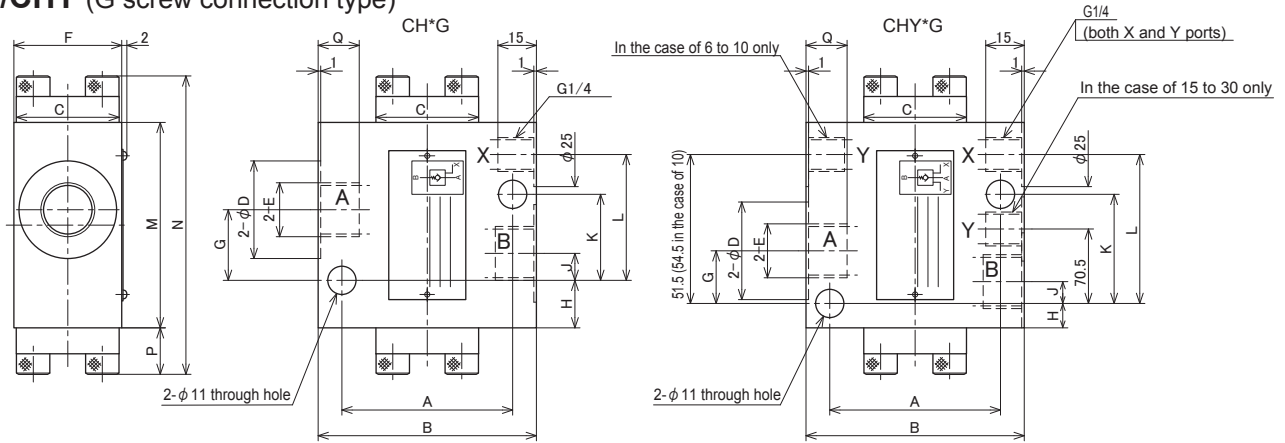

Type	Nominal dimension	A	B	C	D	E	F	G	H	J	K	L	M	N	P	Q
CH	6	66.5	85	40	25	G 1/4	42	27.5	18.5	10.5	33.5	49	80	116	18	15
	8	66.5	85	40	32	G 3/8	42	27.5	18.5	10.5	33.5	49	80	116	18	15
	10	66.5	85	40	38	G 1/2	42	27.5	18.5	10.5	33.5	49	80	116	18	16
	15	79.5	100	58	45	G 3/4	60	36.5	17.5	13	50.5	65.5	95	135	20	17
	20	79.5	100	58	52	G 1	60	36.5	17.5	13	50.5	65.5	95	135	20	18
	25	97	120	73	63	G 1 1/4	75	54.5	15.5	20.5	71.5	87.5	115	173	29	24
CHY	6	66.5	85	40	25	G 1/4	42	23.5	16.5	12.5	35.5	51	80	116	18	15
	8	66.5	85	40	32	G 3/8	42	19	16.5	12.5	35.5	51	80	116	18	15
	10	66.5	85	40	38	G 1/2	42	19.5	13.5	15.5	38.5	54	80	116	18	16
	15	74	120	73	45	G 3/4	75	54.5	15.5	20.5	84	97.5	125	183	29	17
	20	74	120	73	52	G 1	75	54.5	15.5	18	84	97.5	125	183	29	18
	25	74	120	73	63	G 1 1/4	75	54.5	15.5	18	84	97.5	125	183	29	24
	30	74	120	73	65	G 1 1/2	75	54.5	15.5	18	84	97.5	125	183	29	24

●CH/CHY (R screw connection type)

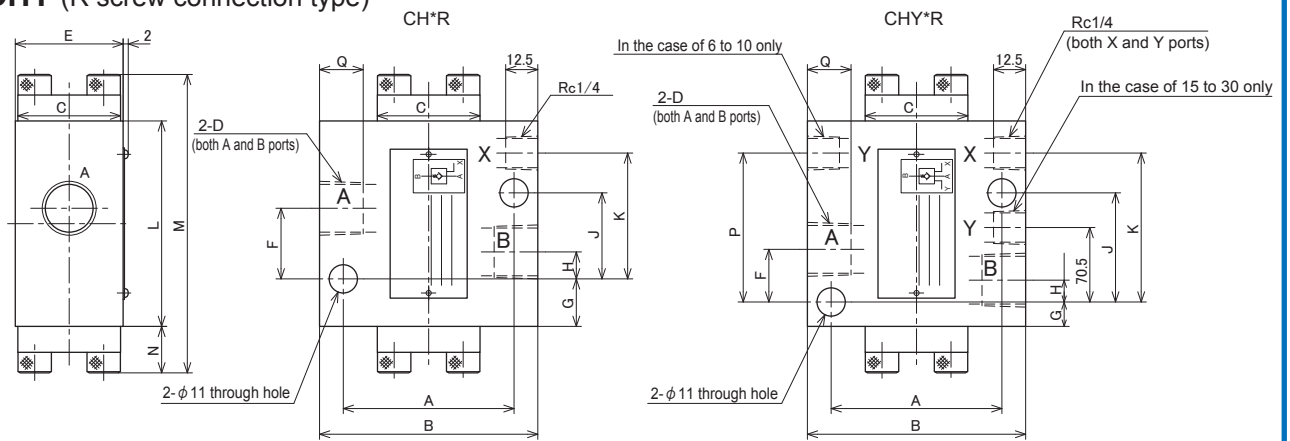

Type	Nominal dimension	A	B	C	D	E	F	G	H	J	K	L	M	N	P	Q
CH	6	66.5	85	40	Rc 1/4	42	27.5	18.5	10.5	33.5	49	80	116	18	—	12.5
	8	66.5	85	40	Rc 3/8	42	27.5	18.5	10.5	33.5	49	80	116	18	—	14
	10	66.5	85	40	Rc 1/2	42	27.5	18.5	10.5	33.5	49	80	116	18	—	17
	15	79.5	100	58	Rc 3/4	60	36.5	17.5	13	50.5	65.5	95	135	20	—	19
	20	79.5	100	58	Rc 1	60	36.5	17.5	13	50.5	65.5	95	135	20	—	22
	25	97	120	73	Rc 1 1/4	75	54.5	15.5	20.5	71.5	87.5	115	173	29	—	24.5
CHY	6	66.5	85	40	Rc 1/4	42	23.5	16.5	12.5	35.5	51	80	116	18	51.5	12.5
	8	66.5	85	40	Rc 3/8	42	19	16.5	12.5	35.5	51	80	116	18	51.5	14
	10	66.5	85	40	Rc 1/2	42	19.5	13.5	15.5	38.5	54	80	116	18	54.5	17
	15	74	120	73	Rc 3/4	75	54.5	15.5	20.5	84	97.5	125	183	29	—	19
	20	74	120	73	Rc 1	75	54.5	15.5	18	84	97.5	125	183	29	—	22
	25	74	120	73	Rc 1 1/4	75	54.5	15.5	18	84	97.5	125	183	29	—	24.5
	30	74	120	73	Rc 1 1/2	75	54.5	15.5	18	84	97.5	125	183	29	—	25.5

● **CH/CHY** (gasket connection type)

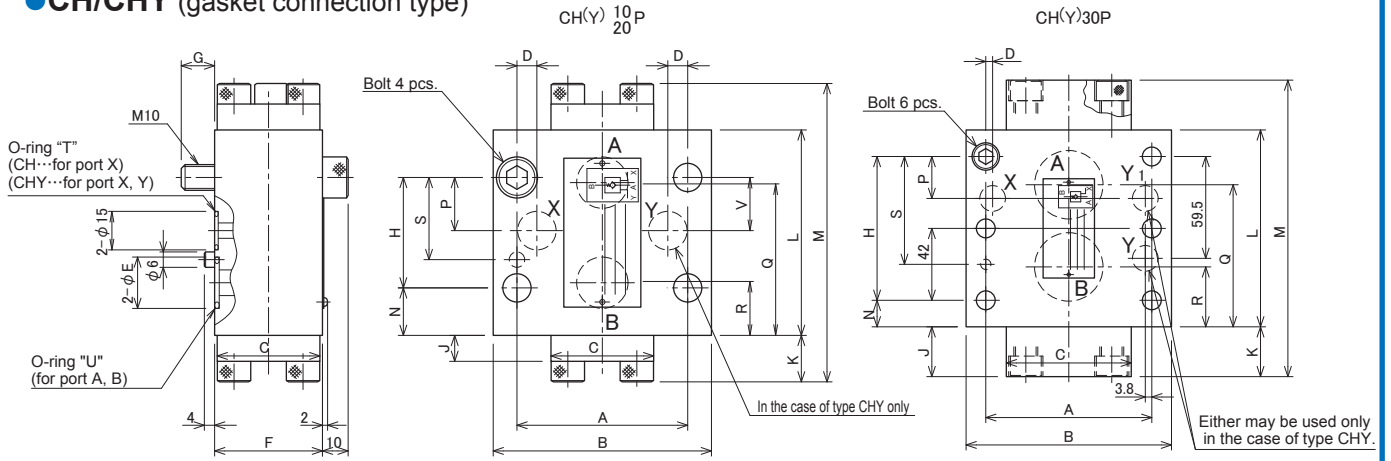

Type	Nominal dimension	A	B	C	D	E	F	G	H	J	K	L	M	N	P
CH	10	66.5	85	40	7.8	20	42	13	43	10	18	80	116	18.5	21.5
	20	79.5	100	58	6.3	30	60	15	60.5	10	20	95	135	17.3	20.8
	30	97	120	73	4	40	75	15	84	29	29	115	173	15.5	24.5
CHY	10	66.5	85	40	7.8	20	42	13	43	10	18	80	116	18.5	21.5
	20	79.5	100	58	6.3	30	60	15	60.5	10	20	105	145	17.3	20.8
	30	97	120	73	4	40	75	15	84	29	29	125	183	15.5	24.5

Type	Nominal dimension	Q	R	S	O-ring dimension			V	
					X port "T"	Y port	A-B Port "U"		
CH	10	54.3	25.8	32	JIS B2401 P11 Hs90	/	JIS B2401 P16 Hs90	/	
	20	66.5	28.5	44.5			JIS B2401 G25 Hs90		
	30	83	32	63			JIS B2401 G35 Hs90		
CHY	10	54.3	25.8	32			JIS B2401 P16 Hs90		21.5
	20	66.5	28.5	44.5			JIS B2401 G25 Hs90		39.7
	30	83	32	63			JIS B2401 G35 Hs90		/

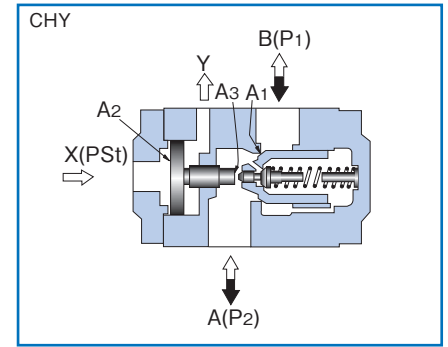
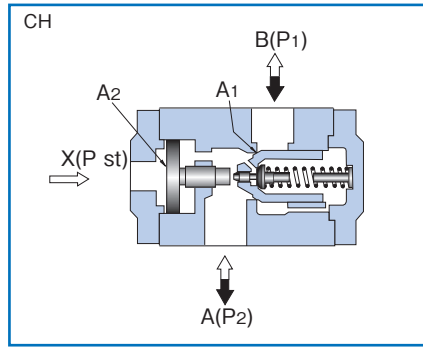
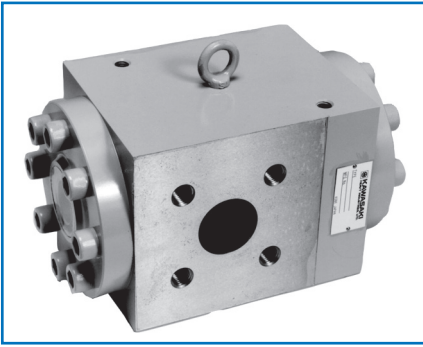

Overview

This pilot check valve operates the pilot using remote pressure and allows for back flow as appropriate. This valve is mainly used in a press or lift to prevent load from falling due to leakage of the hydraulic circuit.

Features

This is of decompression type. As the main valve opens after the pilot valve opens, smooth switching without shocks can be performed under high pressure and large capacity.

Type indication

CH Y 52 F - 10 - 10 -

- CH**: Pilot operated check valve
- Y**: Drain system
 - No symbol = Internal drain
 - Y = External drain
- 52**: Nominal dimension (Gasket connection type is 52, 62 and 82 only.)
- F**: Connection method
 - F = Flange connection type
 - P = Gasket connection type
- 10**: Cracking pressure
 - 10 = 0.10MPa (1.0kgf/cm²)
 - 30 = 0.29MPa (3.0kgf/cm²)
 - 45 = 0.44MPa (4.5kgf/cm²)
- 10**: Series number: 10
- : Type of hydraulic oil
 - No symbol = Mineral based hydraulic oil
 - V = Phosphate ester based hydraulic oil
 - W = Fatty ester based hydraulic oil
 - Water-glycol based hydraulic oil

* If you use cracking pressure of 45, please contact us in advance.

Specifications

Nominal dimension	52	62	82	102	125	150
Maximum working pressure MPa(kgf/cm ²)	30.9(315)					
Maximum flow rate L/min	700	1100	1800	3000	4400	6400
Maximum pilot pressure MPa (kgf/cm ²)	30.9(315)					
Pilot volume cm ³	Port X	91	153	238	458	834
	Port Y (however, only for CHY)	83.5	142	220	422	757
Mass kg	32	42	84	152	300	480

Flange

Valve type	Maximum working pressure	Flange type	Connection diameter	Mass
CH(Y)52F	20.6MPa	TFAA-40	2B	2.6kg
	30.9MPa	TFXA-40	2B	2.7kg
CH(Y)62F	20.6MPa	TFAA-50	2 $\frac{1}{2}$ B	3.9kg
	30.9MPa	TFXA-50	2 $\frac{1}{2}$ B	4.5kg
CH(Y)82F	20.6MPa	TFAA-63	3B	7.9kg
	30.9MPa	TFXA-63	3B	8.5kg
CH(Y)102F	20.6MPa	TFAA-80	4B	13kg
	30.9MPa	TFXA-80	4B	14kg
CH(Y)125F	20.6MPa	TFAA-125	6B	42kg
	30.9MPa	TFXA-125	6B	45kg
CH(Y)150F	20.6MPa	TFAA-150	8B	70kg
	30.9MPa	TFXA-150	8B	75kg

When you use a flange, please place an order for the above flange type.
For the dimension drawing, refer to page 16 of the appendix.

Accessories

● Mounting bolt

Type	Hexagon socket head cap thread	Quantity	Tightening torque N·m (kgf·cm)
CH/CHY52P	M16×165L	6 pcs.	235.2±35.2 (2400±360)
CH/CHY62P	M20×180L	6 pcs.	431.2±64.6 (4400±660)
CH/CHY82P	M20×225L	6 pcs.	

Precautions in use

● Method of obtaining minimum required pilot pressure

(refer to symbols in the structural drawing)

In the case of CH

$$P_{st} = P_1 \times \frac{A_1}{A_2} + 0.5\text{MPa} \quad (P_2=0)$$

In the case of CHY

$$P_{st} = \frac{P_1 \times A_1 - P_2 \times (A_1 - A_3)}{A_2} + 0.5\text{MPa}$$

P_{st}: Minimum required pilot pressure (MPa)

P₁: Load pressure (pressure of port B) (MPa)

P₂: Back pressure (pressure of port A) (MPa)

A₁: Pressure receiving area of poppet (cm²)

A₂: Pressure receiving area of lifting piston (cm²)

A₃: Pressure receiving area of lifting piston rod (cm²)

Nominal dimension	A ₁	A ₂	A ₃
CH/CHY52	21.24	47.78	3.8
62	30.19	66.47	4.9
82	43.0	95.0	7.06
102	65.47	143.14	11.34
125	103.87	213.60	19.64
150	149.57	320.47	19.64

(Note) For minimum required pilot pressure (P_{st}), low pilot operated check valves for pilot pressure lower than P_{st} obtained from the above (pilot pressure equivalent to approximately 1/8 of load pressure) are also available (KSV/KSL type). If you need the above valve, please contact us.

● Method of using internal drain type and external drain type

When port A is directly connected to the tank during reverse free flow, the internal drain type is generally used. However, if back pressure is applied to port A, be sure to use the external drain type.

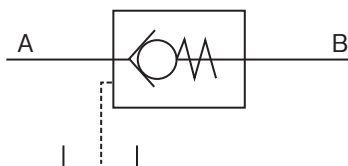

Dimension drawing

●CH/CHY (Flange connection type)

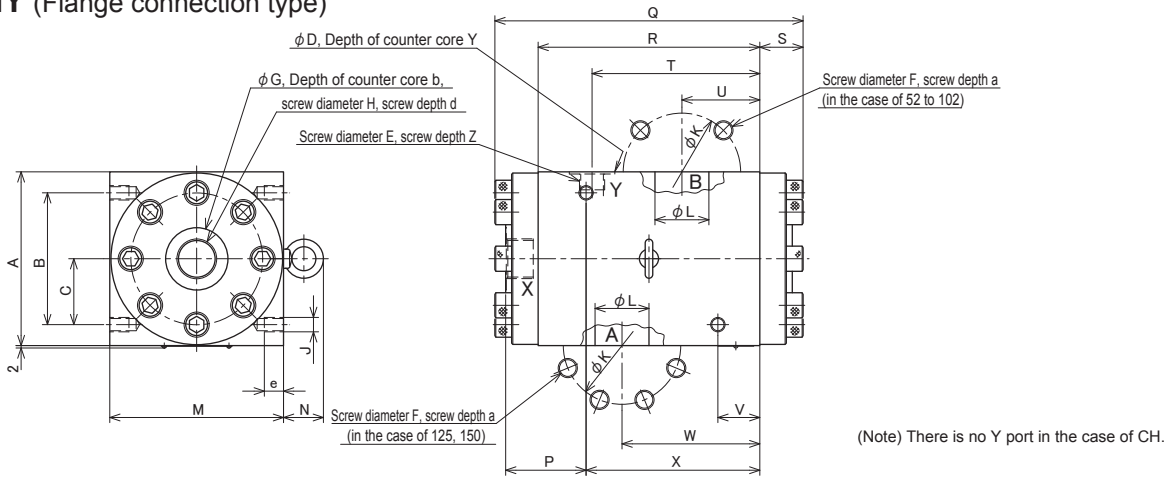

Nominal dimension	A	B	C	D	E	F	G	H	J	K	L	M	N	P
52	145	110	55	38	G 1/2	4-M16	52	G1	4-M12	98	45	145	34	67
62	155	120	60	38	G 1/2	4-M20	52	G1	4-M12	118	55	155	34	75
82	200	130	65	45	G 3/4	4-M24	52	G1	4-M12	145	72	200	42	103
102	230	170	85	45	G 3/4	4-M30	52	G1	4-M16	175	90	250	60	121
125	290	200	100	65	G1 1/2	8-M30	65	G1 1/2	4-M24	245	122	305	60	128
150	350	300	150	65	G1 1/2	8-M36	65	G1 1/2	4-M24	290	150	360	60	134
Nominal dimension	Q	R	S	T	U	V	W	X	Y	Z	a	b	d	e
52	257	185	36	140	65	35	115	145	0.5	15	25	0.5	16	16
62	298	220	39	170	75	35	135	175	0.5	15	30	1	16	16
82	386	270	58	212	100	70	170	210	0.5	16	36	1	16	16
102	461	335	63	262	125	70	210	265	0.5	16	41	1	16	20
125	564	430	67	337	150	70	270	360	1	24	50	1	25	30
150	654	500	77	400	180	70	320	430	1	24	52	1	25	30

●CH/CHY (Gasket connection type)

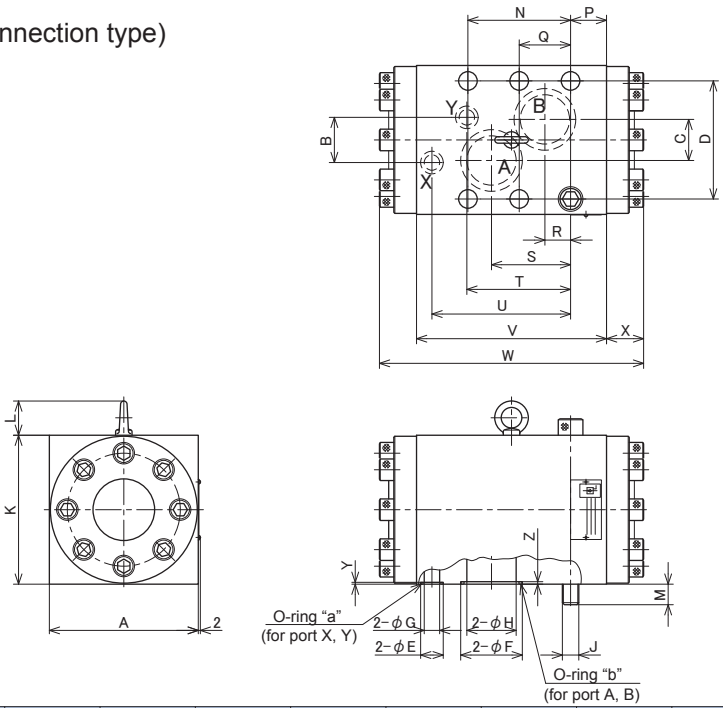

Nominal dimension	A	B	C	D	E	F	G	H	J	K	L	M	N	
52	145	44	40	115	22	60	15	48	6-M16	145	33.3	20	100	
62	155	48	40	125	22	70	15	60	6-M20	155	33.3	25	128	
82	200	60	50	170	22	85	15	75	6-M20	200	41.5	25	140	
Nominal dimension	P	Q	R	S	T	U	V	W	X	Y	Z	a	b	
52	35	50	25	77	101	135	185	257	36	1.8	2.4	JIS B2401 P18 Hs90	G55	JIS B2401 Hs90
62	35	65	34	100	132	170	220	298	39	1.8	2.4		G65	
82	59	70	30	115	151	185	270	386	58	1.8	2.4		G80	

Pressure gauge valve

DG6

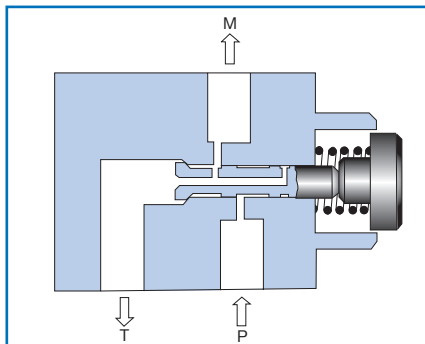

Specifications

- Maximum working pressure 30.9 MPa (315 kgf/cm²)
- Allowable tank pressure 0.05 MPa (5 kgf/cm²)

Hydraulic symbols

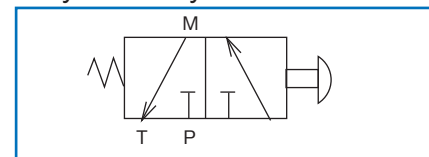

Overview

This pressure gauge valve is a kind of a three-way manual selector lever by manual operation and is used to check the pressure.

Features

1. The casing is structured to be conveniently installed on the panel.
2. The pressure gauge can be joined to the valve main body by threaded port or can be connected to it by a pipe.
3. Pressure can be detected with one touch.
4. The pressure gauge has a longer service life because only tank pressure is applied unless it is used.

Type indication

DG 6 R - 10 - 2 - G38 - []

<p>Pressure gauge valve</p> <p>Nominal dimension 6</p> <p>Connection method G = G thread connection type R = R thread connection type PG = G thread connection type (Port P, T = Gasket connection, Port M = G thread connection) PR = R thread connection type (Port P, T = Gasket connection, Port M = R thread connection)</p> <p>Series number: 10</p>	<p>Type of hydraulic oil No symbol = Mineral based hydraulic oil V = Phosphate ester based hydraulic oil W = Fatty ester based hydraulic oil Water-glycol based hydraulic oil</p> <p>Pressure gauge connector No symbol = Types without pressure gauge connector G14 = Types with G1/4 pressure gauge connector G38 = Types with G3/8 pressure gauge connector G12 = Types with G1/2 pressure gauge connector</p> <p>Position holding method 2 = Spring offset type</p>
--	---

Accessories

● Mounting bolt

Type	Hexagon socket head cap thread	Quantity	Tightening torque N·m (kgf·cm)
DG6	M6×65L	4 pcs.	11.8± 1.7 (120±18)

Dimension drawing

● DG6

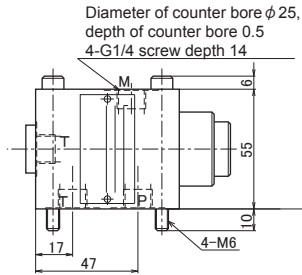
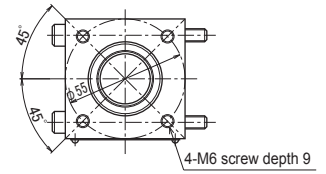
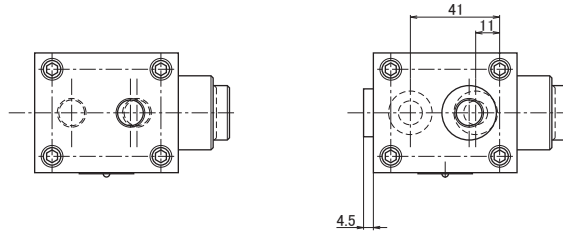
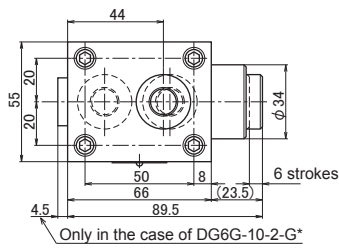

G screw connection type

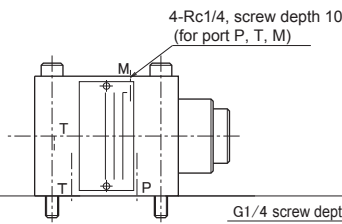

R screw connection type
(Same as G screw connection type other than dimensions entered)

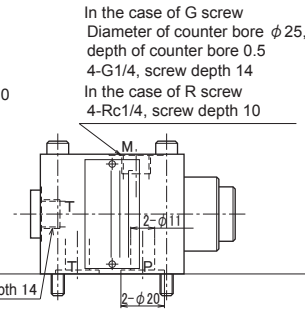

Gasket connection type
(Same as G screw connection type other than dimensions entered)

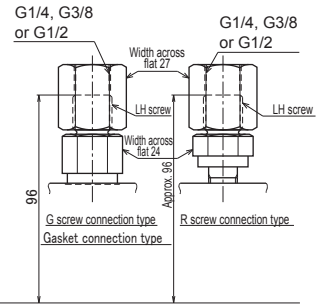

In the case with pressure gauge connector
(Note) In the case of screw connection type, there is T port at two locations and either of the two may be used.

Pressure control valve

	Page
Relief valve – Direct operated type • RD/RDV/RDV1M	2-2
Relief valve – Balanced piston type pilot operated (1) • RB/RBE	2-10
Relief valve – Balanced piston type pilot operated (2) • RB/RBE	2-17
Relief valve – Balanced piston type pilot operated (3) • RB/RBE	2-22
Three stage pressure relief valve • 3RBE	2-27
Relief valve – Balanced piston cartridge type pilot operated • B1M..C	2-30
Pilot operated unloading relief valve (1) • PU/PUE	2-32
Pilot operated unloading relief valve (2) • PU35	2-37
Sequence valve – Direct operated type • SD	2-40
Sequence valve – Balanced piston type pilot operated • SB/SBE	2-43
Pressure reducing valve – Direct operated type • PRD	2-48
Pressure reducing valve – Balanced piston type pilot operated • PRB	2-51
Brake valve • B	2-54
Counterbalance valve • CBD	2-61
Counterbalance valve – with unloading function • KDZ	2-64

In the type selection, we recommend the one indicated in color letters in the type indication explanation.

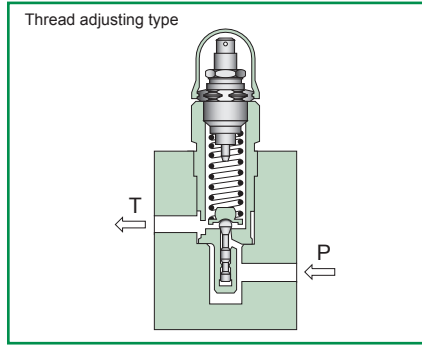

Relief valve – Direct operated type

Overview

This direct operated type relief valve, which is a seat type relief valve, prevents momentary pressure increase of the hydraulic circuit and at the same time is used for load holding.

Features

1. This valve is very responsive and is optimum especially for a relief valve.
2. As a cartridge type is available, it can be incorporated in a manifold in a compact way.
3. As this valve is of seat type, it has less internal leakage compared to the balance type relief valve.
4. As this valve is provided with the chattering preventive mechanism, its operation is stable.

Type indication

RD6C - 10 - 2 / 315 -

Relief valve – Direct operated type

Nominal dimension

- 6, 8, 10, 15
- 20, 25, 30

Connection method

- G = G thread connection type
- GO = G thread connection type (based on JISB2351 0 type)
- R = R thread connection type
- P = Gasket connection type
- C = Cartridge type

Nominal dimension	RD				
	G	GO	R	P	C
6	○	○	○	○	○
8	○	○	○	—	—
10	○	○	○	○	○
15	○	○	○	—	—
20	○	○	○	○	○
25	○	○	○	—	—
30	○	○	○	○	○

Series number: 10

Shape of pressure adjusting part

- 1 = Handle adjustment
- 2 = Thread adjustment (with cap)
- 3 = Handle with key adjustment (nominal dimension 6, 8, 10 only)

Type of hydraulic oil

No symbol = Mineral based hydraulic oil

V = Phosphate ester based hydraulic oil

W = Fatty ester based hydraulic oil

Water-glycol based hydraulic oil

(Note) In the case of the cartridge type, "No symbol" and "W" are identical, and therefore, there is no "W".

Highest adjustment pressure

- 25 = 2.5 MPa (25 kgf/cm²)
- 50 = 4.9 MPa (50 kgf/cm²)
- 100 = 9.8 MPa (100 kgf/cm²)
- 200 = 19.6 MPa (200 kgf/cm²)
- 315 = 30.9 MPa (315 kgf/cm²)
- 400 = 39.2 MPa (400 kgf/cm²)
- 630 = 61.7 MPa (630 kgf/cm²)

Nominal dimension	Highest adjustment pressure						
	25	50	100	200	315	400	630
6						○	—
8						○	○
10						○	○
15					○ (All)	○	—
20					○	○	—
25					—	—	—
30					—	—	—

(Note) As the minimum set pressure differs depending on the flow rate, refer to "Pressure override characteristics".

● Hydraulic symbols

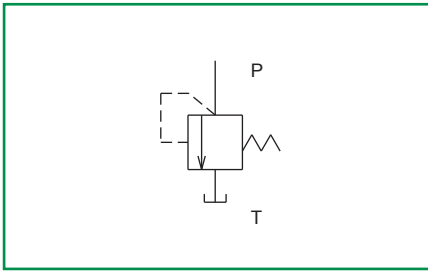

● Pressure increase value per turn (clockwise) of adjust thread MPa (kgf/cm²)

Highest adjustment pressure \ Nominal dimension	6	8, 10	15, 20	25, 30
25	0.4 (4.3)	0.4 (3.9)	0.4 (3.9)	0.4 (3.9)
50	0.8 (8.4)	0.8 (8.6)	0.7 (7.0)	0.8 (7.9)
100	1.5 (15.8)	1.8 (18.0)	1.7 (17.1)	1.6 (16.1)
200	3.7 (38.2)	3.4 (35.0)	4.6 (47.1)	4.2 (43.2)
315	5.9 (60.7)	5.4 (55.1)	6.4 (65.4)	6.1 (62.3)
400	10.8 (110.7)	6.5 (66.1)	10.9 (111.5)	————
630	————	12.8 (130.8)	————	————

(Note) As the above value is a calculated value, there are slight variations in the product.

Specifications

Nominal dimension		6	8	10	15	20	25	30
Maximum working pressure MPa (kgf/cm ²)	Port P	39.2 (400)	61.7 (630)		39.2 (400)		30.9 (315)	
	Port T	30.9 (315)						
Maximum flow rate L/min (Note)		50	120		250		330	
Mass kg	Thread connection type	1.5	3.7		6.4		13.9	
	Gasket connection type	1.5	—	3.7	—	6.4	—	13.9
	Cartridge type	0.4	—	0.5	—	1.0	—	2.2

(Note) As the maximum flow rate differs depending on the set pressure, refer to "Pressure override characteristics".

Sub-plate

Valve type	Sub-plate type	Connection diameter	Mass
RD6P	P-RD6R14-0	Rc 1/4	1.3kg
	P-RD6G14-0	G 1/4	
RD10P	P-RD10R12-0	Rc 1/2	3kg
	P-RD10G12-0	G 1/2	
RD20P	P-RD20R34-0	Rc 3/4	5.3kg
	P-RD20G34-0	G 3/4	
	P-RD20R1-0	Rc 1	
	P-RD20G1-0	G1	
RD30P	P-RD30R54-0	Rc1 1/4	10.5kg
	P-RD30G54-0	G1 1/4	
	P-RD30R32-0	Rc1 1/2	
	P-RD30G32-0	G1 1/2	

When you use a sub-plate, please place an order for the above sub-plate type.
For the dimension drawing, refer to page 8 of the appendix.

Accessories

● Mounting bolt

Type	Hexagon socket head cap thread	Quantity	Tightening torque N·m (kgf·cm)
RD6P	M6×50L	4	11.8 ± 1.7 (120 ± 18)
RD10P	M8×70L	4	29.4 ± 4.4 (300 ± 45)
RD20P	M8×80L	4	
RD30P	M10×105L	4	56.8 ± 8.5 (580 ± 87)

Type indication (relief valve – direct operated type for vent control)

RDV 6C - 10 - 2 / 315 - 12 -

Relief valve – direct operated type for vent control

Nominal dimension
6, 10

Connection method

- G = G thread connection type
- GO = G thread connection type (based on JISB2351 0 type)
- R = R thread connection type
- P = Gasket connection type
- C = Cartridge type

Series number: 10

Shape of pressure adjusting part

- 1 = Handle adjustment
- 2 = Thread adjustment (with cap)
- 3 = Handle with key adjustment

Type of hydraulic oil

- No symbol = Mineral based hydraulic oil
- V = Phosphate ester based hydraulic oil
- W = Fatty ester based hydraulic oil
- Water-glycol based hydraulic oil

(Note) In the case of the cartridge type, "No symbol" and "W" are identical, and therefore, there is no "W".

P port restriction contraction diameter

- 10 = ϕ 1.0mm
- 12 = ϕ 1.2mm
- 15 = ϕ 1.5mm
- 18 = ϕ 1.8mm

Highest adjustment pressure

- 100 = 9.8MPa (100kgf/cm²)
- 315 = 30.9MPa (315kgf/cm²)

Specifications

Nominal dimension		6
Maximum working pressure MPa (kgf/cm ²)	Port P	39.2 (400)
	Port T	30.9 (315)
Maximum flow rate L/min		3 (Note)
Mass kg	Thread connection type	1.5
	Gasket connection type	1.5
	Cartridge type	0.4

(Note) Be very careful that the minimum adjustment pressure and pressure override values differ depending on the flow rate used and restriction and contraction diameters of the main relief valve and relief valve for vent control.

• For the pressure increase value per turn of the adjust thread, refer to the section of the type number index "RD6 to 30".

Precautions in use

- Make the vent conduit as short as possible and the inside diameter of piping as small as possible. If the inside volume of the vent conduit is large, control may become unstable.
- Do not connect the tank piping to other tank piping but connect it directly to the tank.

Type indication (relief valve for panel mounted vent control)

RDV 1M 6 R - 10 - 3 / 315 - 10 -

Relief valve for panel mounted vent control

Nominal dimension
6

Connection method

- R = R thread connection type

Series number: 10

Shape of pressure adjusting part

- 3 = Handle with key adjustment

Type of hydraulic oil

- No symbol = Mineral based hydraulic oil
- Fatty ester based hydraulic oil
- Water-glycol based hydraulic oil
- V = Phosphate ester based hydraulic oil

P port restriction contraction diameter

- 10 = ϕ 1.0mm
- 12 = ϕ 1.2mm
- 15 = ϕ 1.5mm
- 18 = ϕ 1.8mm

Highest adjustment pressure

- 315 = 30.9MPa (315kgf/cm²)
- (Pressure adjustment range = 2 to 30.9 MPa)

Specifications

Nominal dimension	6
Maximum working pressure MPa (kgf/cm ²)	30.9 (315)
Maximum flow rate L/min	3 (Note)
Operating force	Maximum approx. 2 N·m (20 kgf·cm) (however, in the case of back pressure being 0)
Mass kg	1.5

(Note) Be very careful that the minimum adjustment pressure and pressure override values differ depending on the flow rate used and restriction and contraction diameters of the main relief valve and relief valve for vent control.

Precautions in use

- Make the vent conduit as short as possible and the inside diameter of piping as small as possible. If the inside volume of the vent conduit is large, control may become unstable.
- Do not connect the tank piping to other tank piping but connect it directly to the tank.

Pressure override characteristics (viscosity 36 mm²/s (cSt))

●RD6/25

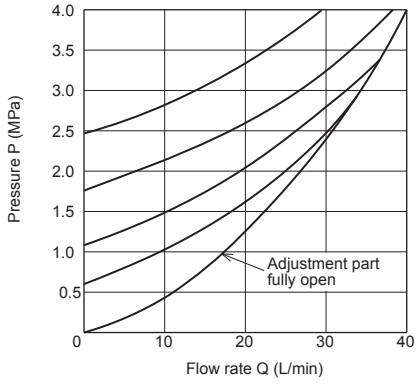

●RD6/50

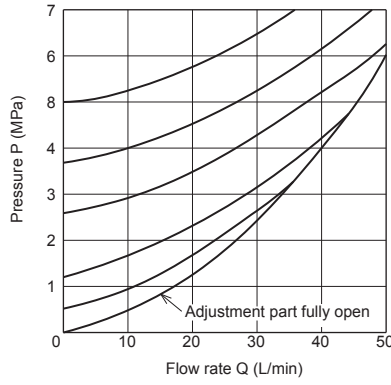

●RD6/100

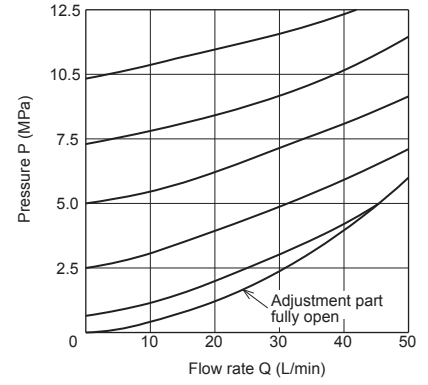

●RD6/200

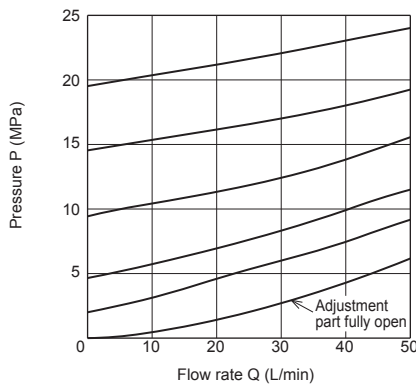

●RD6/315

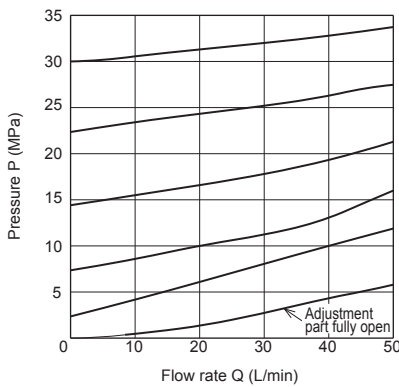

●RD₁₀⁸/25

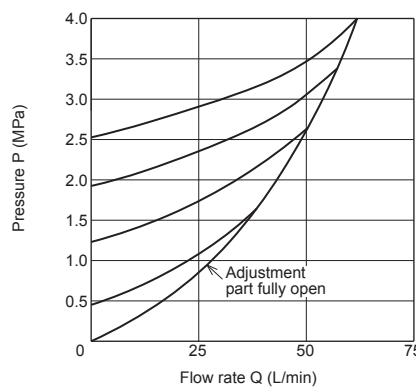

●RD₁₀⁸/50

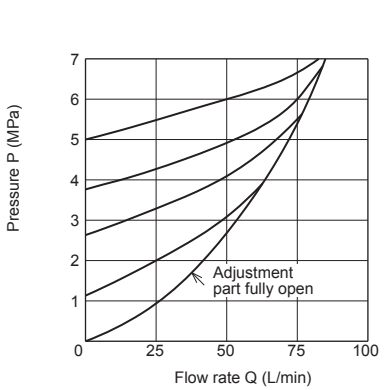

●RD₁₀⁸/100

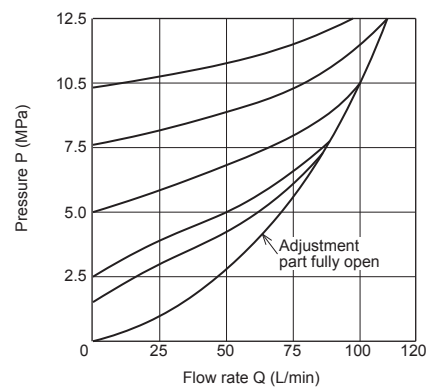

●RD₁₀⁸/200

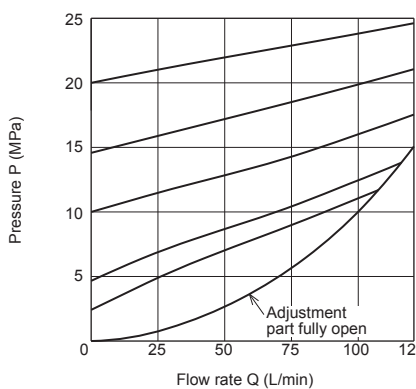

●RD₁₀⁸/315

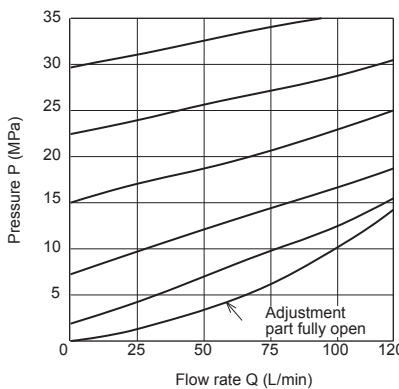

● RD₂₀¹⁵/25

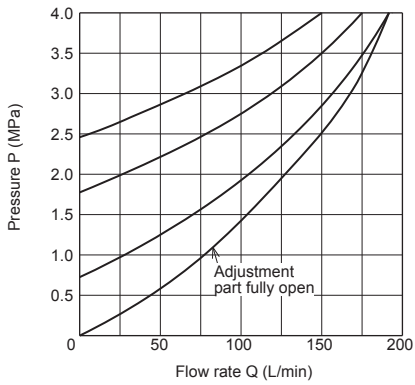

● RD₂₀¹⁵/50

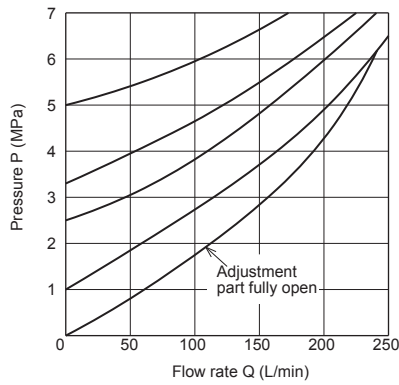

● RD₂₀¹⁵/100

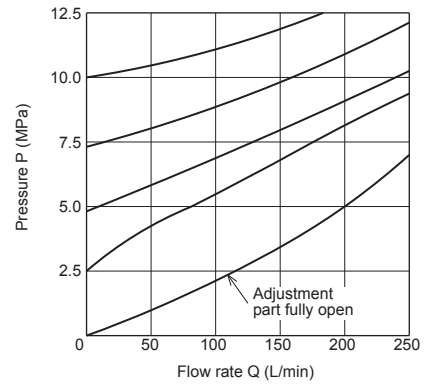

● RD₂₀¹⁵/200

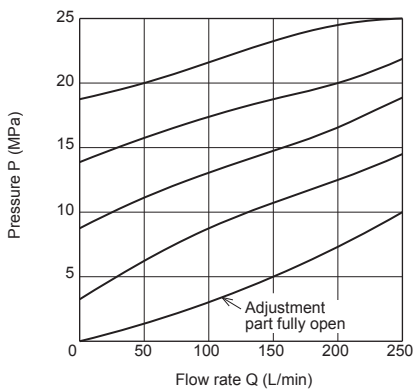

● RD₂₀¹⁵/315

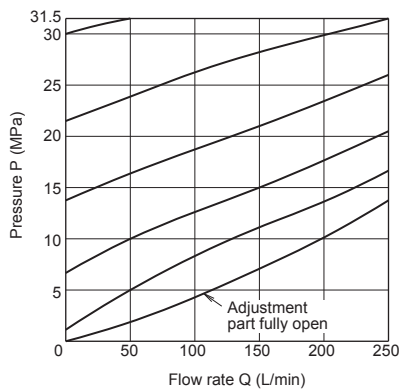

● RD₃₀²⁵/25

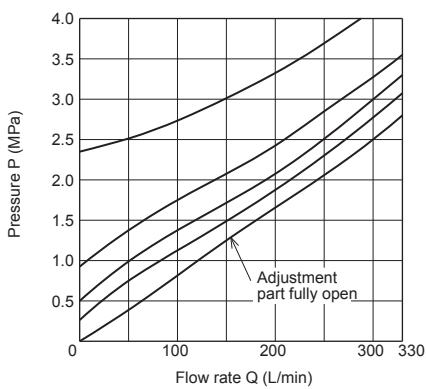

● RD₃₀²⁵/50

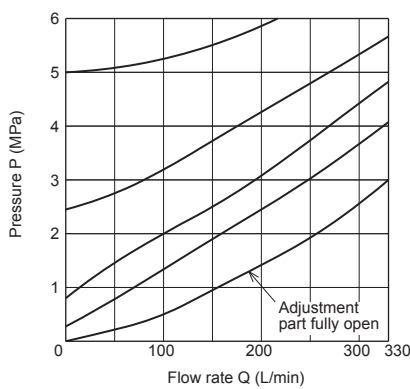

● RD₃₀²⁵/100

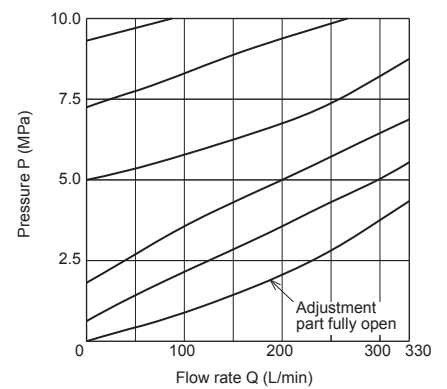

● RD₃₀²⁵/200

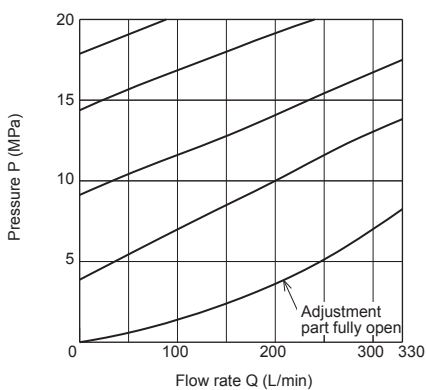

● RD₃₀²⁵/315

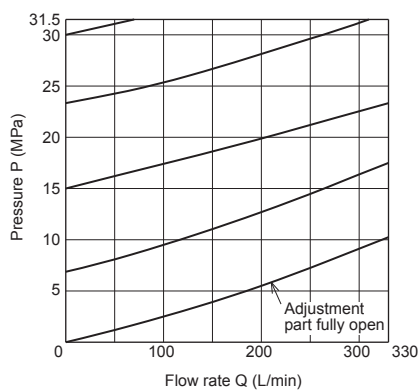

Dimension drawing

●RD*G/R

●RDV6G/R

●Handle adjusting type
(in the case of nominal dimension other than 25, 30)

●Handle adjusting type
(in the case of nominal dimension of 25, 30)

●Screw adjusting type

●Handle with key adjusting type

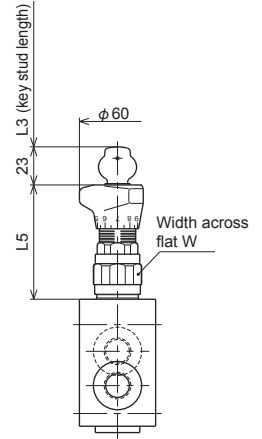
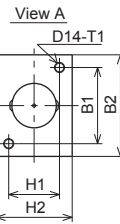
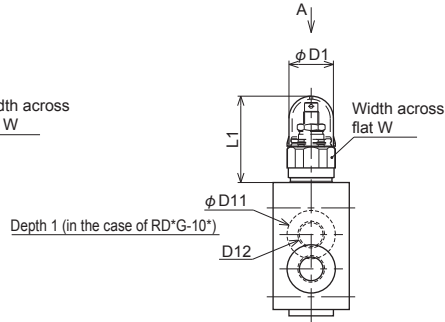
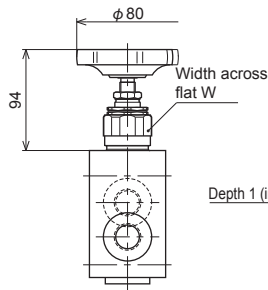
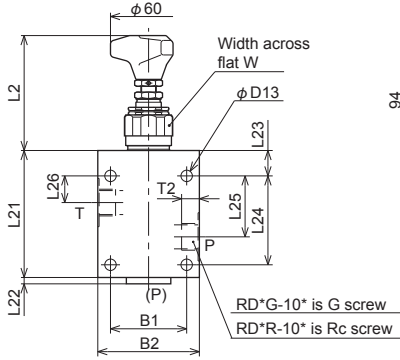

Nominal dimension		B1	B2	D1	D11	D12	D13	D14	H1	H2	L1	L2	L3	L5	L21	L22	L23	L24	L25	L26	W	T1	T2
6	G	45	60	35	25	G 1/4	6.6	2-M6	25	40	72	94	15	98	80	4	15	55	40	20	32	10	14
	Rc 1/4					12.5																	
8	G	60	80	35	32	G 3/8	9	2-M8	40	60	68	91	15	94	100	5	20	70	48	21	36	15	15
	Rc 3/8					14																	
10	G	70	100	40	38	G 1/2	11	2-M10	50	70	65	88	15	91	135	5	20	100	65	34	46	18	15
	Rc 1/2					17																	
15	G	70	100	40	45	G 3/4	11	2-M10	50	70	65	88	15	91	135	5	20	100	65	34	46	18	18
	Rc 3/4					19																	
20	G	100	130	50	52	G 1	11	2-M10	60	90	83	-	-	-	180	5	25	130	85	35	60	20	19
	Rc 1					21																	
25	G	100	130	50	63	G 1 1/4	11	2-M10	60	90	83	-	-	-	180	5	25	130	85	35	60	20	25
	Rc 1 1/4					24.5																	
30	G	100	130	50	65	G 1 1/2	11	2-M10	60	90	83	-	-	-	180	5	25	130	85	35	60	20	25
	Rc 1 1/2					25.5																	

●RD*P

●RDV6P

●Handle adjusting type
(in the case of nominal dimension of 30)

●Handle adjusting type
(in the case of nominal dimension other than 30)

●Screw adjusting type

●Handle with key adjusting type

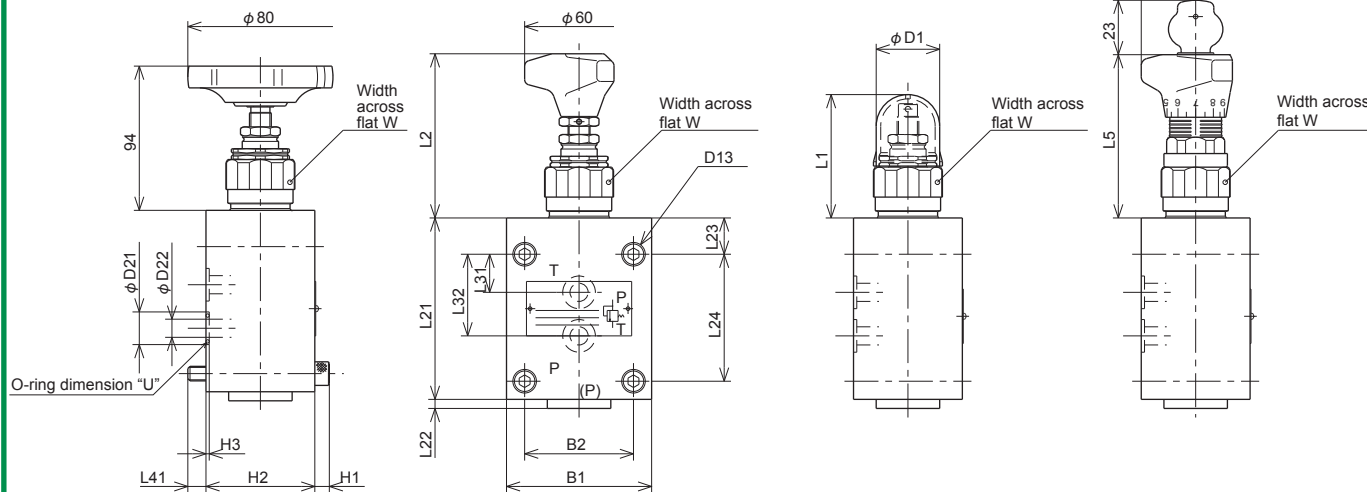

Nominal dimension	B1	B2	D1	D13	D21	D22	H1	H2	H3	L1	L2	L5	L21	L22	L23	L24	L31	L32	L41	W	O-ring dimension "U"
6	60	45	35	4-M6	10	6	6	40	1.4	72	94	98	80	4	15	55	20	40	10	32	2-JIS B2401 P7 Hs90
10	80	60		4-M8	18	10	8	60	1.8	68	91	94	100		20	70	21	45		36	2-JIS B2401 P14 Hs90
20	100	70	40	4-M10	28	20	8	70	2.7	65	88	91	135	5	20	100	34	65	15	46	2-JIS B2401 P22A Hs90
30	130	100	50		40	30	10	90		83	—	—	180		25	130	35	85		60	2-JIS B2401 P34 Hs90

●RD*C

●RDV6C

●Handle adjusting type
(in the case of nominal dimension of 30)

●Handle adjusting type
(in the case of nominal dimension other than 30)

●Screw adjusting type

●Handle with key adjusting type

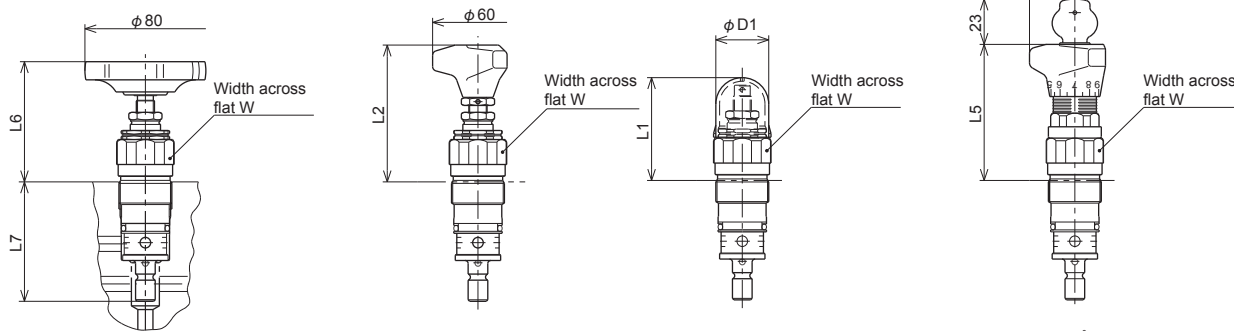

Nominal dimension	D1	D2	L1	L2	L5	L6	L7	W	D11	D12	D13	D14
6	34	60	72	94	98	66	32	M28×1.5	25H8	6	15	
10	40	60	68	91	94			79	36	M35×1.5	32H8	10
20	50	83	65	88	91	109	46	M45×1.5	40H8	20	24	
30	—	—	—	—	—	94	136	M60×2	55H8	30	38.75	

Nominal dimension	D15	D16	L11	L12	L13	L14	L15	L17	L18	Opposite side W tightening torque N · m (kgf · cm)
6	24.9 or more	6	15	19	30 or more	35	45	56.5	66.5	117.6 (1200)
10	31.9 or more	10	18	23	35 or more	41	52	67.5	82	137.2 (1400)
20	39.9 or more	20	21	27	45 or more	54	70	91.5	112	166.6 (1700)
30	54.9 or more	30	23	29		60	84	113.5	143	294.1 (3000)

● RDV1M6R

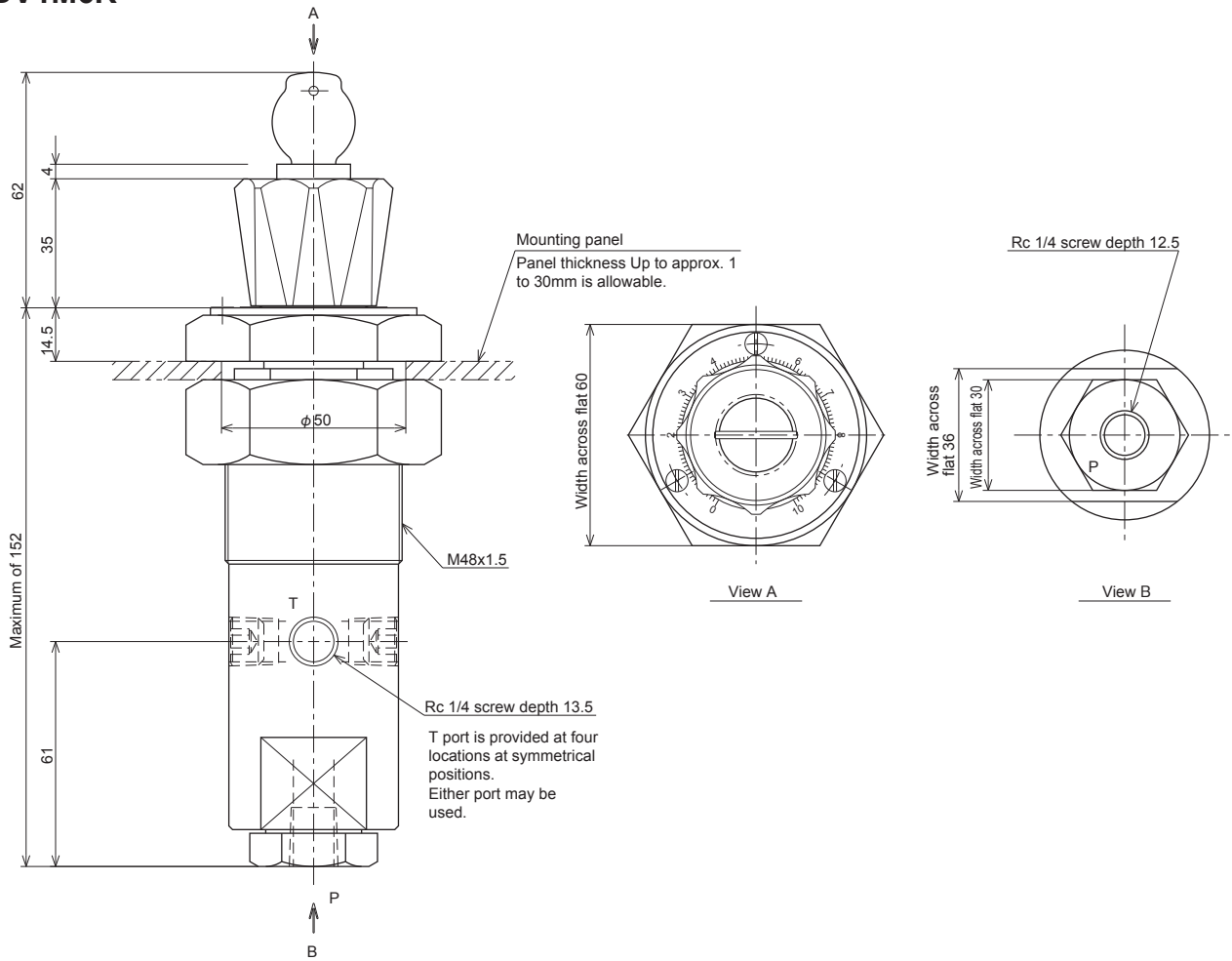

Relief valve – Direct operated type

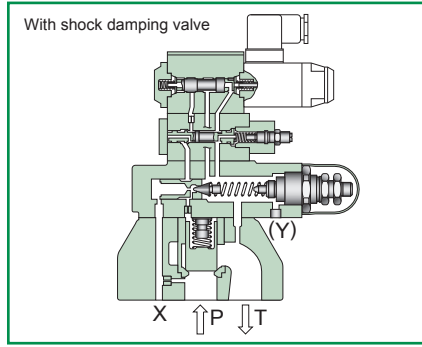
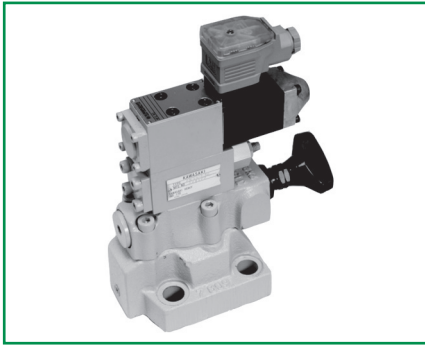

Relief valve – Balanced piston type pilot operated (1)

Overview

This balanced piston type pilot operated relief valve, which is a seat type relief valve, regulates the highest pressure of the hydraulic circuit and at the same time prevents overload of the hydraulic equipment and drive machines and sets pressure for control of the hydraulic equipment. The relief valve with unloading function is used for loading and unloading the circuit pressure with electrical signals.

Features

1. As this valve has a larger seat diameter than that of a general balance type relief valve, it has good responsiveness and flow resistance when unloaded is small.
2. Pressure override is small.
3. Operation is correct and both responsiveness and stability are good.
4. The relief valve with unloading function can perform shockless, smooth unloading if it is used together with the shock damping valve (refer to the section of the type number index "ZNS5").

Type indication

RB

Relief valve - balanced piston type pilot operated

Nominal dimension

Nominal dimension	RB*P	RB*C
10	○	○
20	○	—
30	○	○

Connection method

- P = Gasket connection type
- C = Cartridge type

Series number : 10

Shape of pressure adjusting part

- 1 = Handle adjustment
- 2 = Thread adjustment (with cap)
- 3 = Handle with key adjustment

RB10P-10-1/315XY-

Type of hydraulic oil

- No symbol = Mineral based hydraulic oil
- V = Phosphate ester based hydraulic oil
- W = Fatty ester based hydraulic oil
- Water-glycol based hydraulic oil

Drain system

- No symbol = Internal drain
- Y = External drain

Vent port

- No symbol = Without vent port
- X = With vent port (gasket connection type is X only) (cartridge type is no symbol only)

Highest adjustment pressure

- 100 = 9.8MPa (100kgf/cm²)
- 315 = 30.9MPa (315kgf/cm²)

Hydraulic symbols

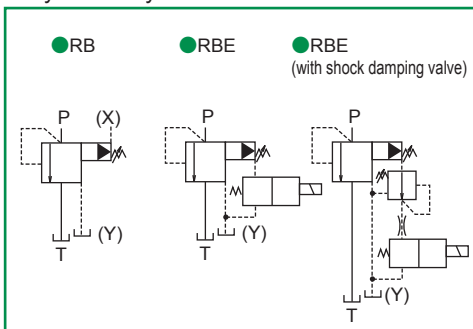

If you wish to purchase a relief valve with a check valve, refer to the section of the type number index "ZA10, 20, 30".

Hydraulic symbols

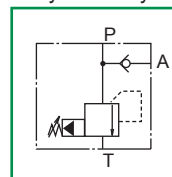

Pressure increase value per turn (clockwise) of adjust thread MPa (kgf/cm²)

Nominal dimension	10, 20, 30
Highest adjustment pressure	1.75(17.8)
100	14.1(143.9)
315	

(Note) As the above value is a calculated value, there are slight variations in the product.

Type indication

RBE

R B E 10 P - 10 - B 1 / 315 X Y - W D 24 C L - S -

Relief valve

- Balanced piston type pilot operated (with solenoid valve)

Nominal dimension

Nominal dimension	RBE*P	RBE*C
10	○	○
20	○	—
30	○	○

Connection method

P = Gasket connection type
C = Cartridge type

Series number: 10

Vent circuit

A = Normal close

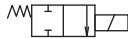

B = Normal open



Shape of pressure adjusting part

- 1 = Handle adjustment
- 2 = Thread adjustment (with cap)
- 3 = Handle with key adjustment

Highest adjustment pressure

100 = 9.8MPa (100kgf/cm²)
315 = 30.9MPa (315kgf/cm²)

Vent port

No symbol = Without vent port (cartridge type)
X = With vent port (gasket connection type)

Drain system

No symbol = Internal drain
Y = External drain

Type of hydraulic oil

No symbol = Mineral based hydraulic oil
V = Phosphate ester based hydraulic oil
W = Fatty ester based hydraulic oil
W1 = Water-glycol based hydraulic oil

Shock damping valve provided or not

No symbol = Without shock damping valve
S = With shock damping valve

Electric connection symbol

symbol	Explanation	Input power supply		
		A	D	R
B	With DIN connector	○	○	—
C	With DIN large connector	○	○	○
CL	With DIN large connector with lamp	○	○	—

Input voltage

12 = 12V
24 = 24V
100 = 100V
200 = 200V

*For details of voltage specifications, refer to "Solenoid specifications" of the solenoid operated directional valve "DE5".

*For other power supply, please contact us.

Input power supply

A = Alternating current
D = Direct current
R = AC/DC conversion

Solenoid type

W = Wet type (with standard emergency manual operation)

Specifications

Nominal dimension		10	20	30
Maximum working pressure MPa (kgf/cm ²)	Port P, T, X	30.9(315) (Note1)		
	Port Y	RB	30.9(315)	
		RBE	15.7(160)	
Maximum flow rate L/min	RB*P/RBE*P	200	400	600
	RB*C/RBE*C	200	—	600
Highest adjustment pressure MPa (kgf/cm ²)		9.8 (100) or 30.9 (315)		
Type of solenoid operated directional valve (Note 2)		Equivalent to DE5P-2 ⁰¹ / ₀₂		
Type of shock damping valve (Note 3)		ZNS5-1		
Mass kg	RB*P	2.6	3.5	4.4
	RB*C	1.5	—	1.5
	RBE*P	3.8	4.7	5.6
	RBE*C	2.7	—	2.7

(Note 1) However, the maximum working pressure of port T is 15.7 MPa (160 kgf/cm²) in the case of RBE internal drain type.

(Note 2) Refer to the section of the solenoid operated directional valve "DE5".

(Note 3) Refer to the section of the type number index "ZNS5" for the specifications.

Sub-plate

Valve type	Sub-plate type	Connection diameter	Mass
RB(E)10	P-RB10R14-0	Rc 1/4	2.1kg
	P-RB10G14-0	G 1/4	
	P-RB10R38-0	Rc 3/8	
	P-RB10G38-0	G 3/8	
	P-RB10R12-0	Rc 1/2	
	P-RB10G12-0	G 1/2	
RB(E)20	P-RB20R34-0	Rc 3/4	4.4kg
	P-RB20G34-0	G 3/4	
	P-RB20R1-0	Rc1	
	P-RB20G1-0	G1	
RB(E)30	P-RB30R54-0	Rc1 1/4	6.9kg
	P-RB30G54-0	G1 1/4	
	P-RB30R32-0	Rc1 1/2	
	P-RB30G32-0	G1 1/2	

When you use a sub-plate, please place an order for the above sub-plate type. For the dimension drawing, refer to page 5, 6 of the appendix.

Accessories

Mounting bolt

Type	Hexagon socket head cap thread	Quantity	Tightening torque N·m (kgf·cm)
RB(E)10	M12×45L	4 pcs.	98.0 ± 14.7 (1000 ± 150)
RB(E)20	M16×50L	4 pcs.	235.2 ± 35.2 (2400 ± 360)
RB(E)30	M18×50L	4 pcs.	333.2 ± 50.0 (3400 ± 510)

Pressure override characteristics (viscosity 36 mm²/s (cSt))

●RB(E)10

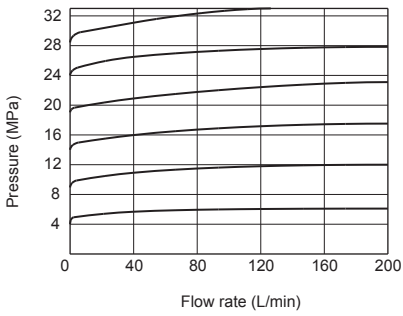

●RB(E)20

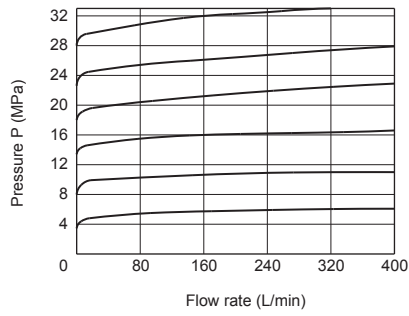

●RB(E)30

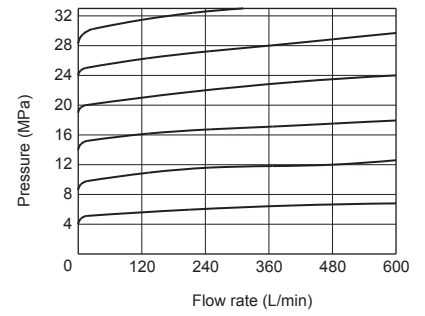

Minimum adjustment pressure characteristics (viscosity 36 mm²/s (cSt))

●RB(E)10

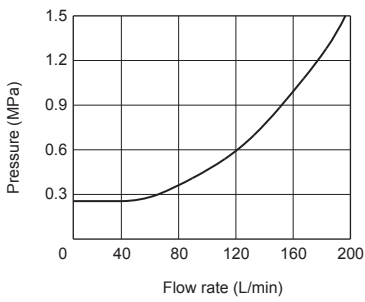

●RB(E)20

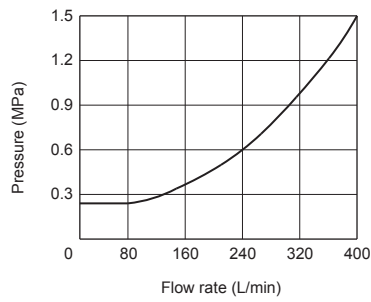

●RB(E)30

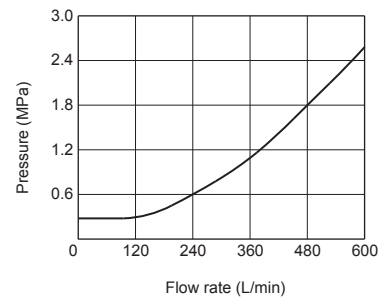

Pilot valve

- The type indication of the pilot valve used for the relief valve – balanced piston type pilot operated is as follows.
If you need the pilot valve only, please specify “pilot valve type” and contact us.

RB10X

RB10X-10-1/315Y-

Pilot relief valve

For RB10, 20, 30

Series number: 10

Shape of pressure adjusting part

- 1 = Handle adjustment
- 2 = Thread adjustment (with cap)
- 3 = Handle with key adjustment

Type of hydraulic oil

- No symbol = Mineral based hydraulic oil
- V = Phosphate ester based hydraulic oil
- W = Fatty ester based hydraulic oil
- Water-glycol based hydraulic oil

Drain system

- No symbol = Internal drain
- Y = External drain

Highest adjustment pressure

- 100 = 9.8MPa (100kgf/cm²)
- 315 = 30.9MPa (315kgf/cm²)

RBE10X

RBE10X-10-B1/315Y-WD24CL-S-

Pilot relief valve

For RBE10, 20, 30

Series number: 10

Vent circuit

A = Normal close

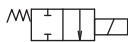

B = Normal open



Shape of pressure adjusting part

- 1 = Handle adjustment
- 2 = Thread adjustment (with cap)
- 3 = Handle with key adjustment

Highest adjustment pressure

- 100 = 9.8MPa (100kgf/cm²)
- 315 = 30.9MPa (315kgf/cm²)

Drain system

- No symbol = Internal drain
- Y = External drain

Solenoid type

W = Wet type (with standard emergency manual operation)

Type of hydraulic oil

- No symbol = Mineral based hydraulic oil
- V = Phosphate ester based hydraulic oil
- W = Fatty ester based hydraulic oil
- W1 = Water-glycol based hydraulic oil

Shock damping valve provided or not

- No symbol = Without shock damping valve
- S = With shock damping valve

Electric connection symbol

symbol	Explanation	Input power supply		
		A	D	R
B	With DIN connector	○	○	—
C	With DIN large connector	○	○	○
CL	With DIN large connector with lamp	○	○	—

Input voltage

- 12 = 12V
- 24 = 24V
- 100 = 100V
- 200 = 200V

*For details of voltage specifications, refer to “Solenoid specifications” of the solenoid operated directional valve “DE5”.
*For other power supply, please contact us.

Input power supply

- A = Alternating current
- D = Direct current
- R = AC/DC conversion

Solenoid operated directional valve

The type indication of the solenoid operated directional valve used for the relief valve with unloading function, three stage pressure relief valve and sequence valve is as follows. For details, please contact us.

DE5P-10-201-WD24CL-

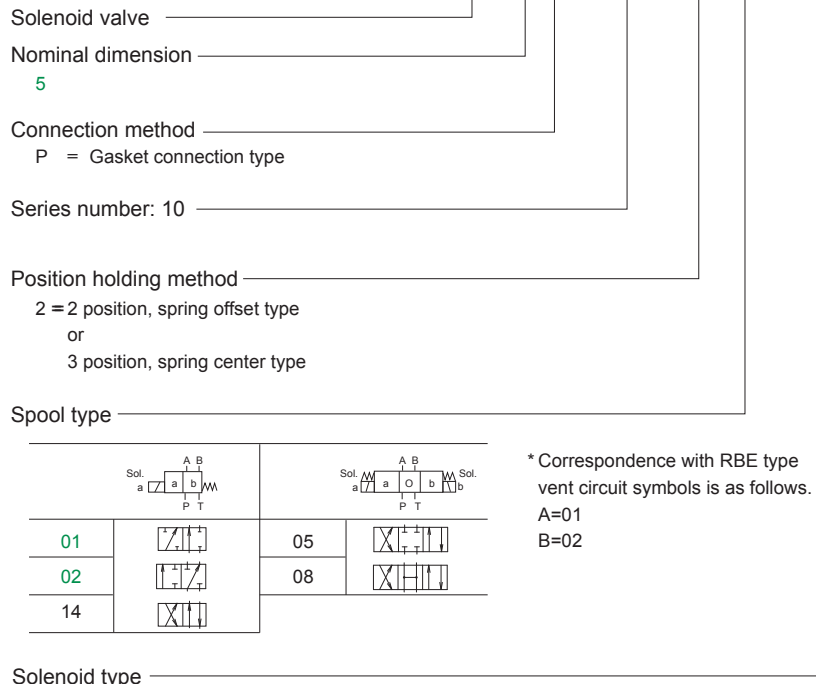

Type of hydraulic oil

- No symbol = Mineral based hydraulic oil
- V = Phosphate ester based hydraulic oil
- W = Fatty ester based hydraulic oil
- W1 = Water-glycol based hydraulic oil

Electric connection symbol

symbol	Explanation	Input power supply		
		A	D	R
B	With DIN connector	○	○	—
C	With DIN large connector	○	○	○
CL	With DIN large connector with lamp	○	○	—

NOTE: In case of CL for DC power supply, there is polarity in the terminal. Refer to the section of the type number index "DE-6" for connection method.

Input voltage

- 12 = 12V
- 24 = 24V
- 100 = 100V
- 200 = 200V

*For other power supply, please contact us.

Input power supply

- A = Alternating current
- D = Direct current
- R = AC/DC conversion

Solenoid type

W = Wet type (with standard emergency manual operation)

Specifications

Switching time ms	Solenoid excitation	AC	25
		DC, with rectifier	40
	Solenoid deenergized	AC	20
		DC	30
		With rectifier	100
Maximum ambient temperature °C			50
Mass kg	Single solenoid type		1.0
	Double solenoid type		1.4

Solenoid specifications

Solenoid type		K-W1D/*				K-G1DS/*			
Power supply and voltage	Power supply	AC				DC			
	Number of connection terminals	3				2			
	Symbol	W100		W200		G12	G24		
	Frequency Hz	50	60	50	60	—	—		
	Voltage V	100	100	110	200	200	220	12	24
Current value A	Holding	0.57	0.58	0.54	0.28	0.29	0.25	2.17	1.08
	Startup	1.81	1.82	1.69	0.85	0.88	0.80	—	—
Energized time		Continuous rating							
Type of coil insulation		H type							
Allowable voltage fluctuation		±10%							
Surge killer		—					With varistor		

Procedure for three terminal solenoid connection

Solenoid type	K-W1D
Connection terminal part schematic diagram	
Connection procedure	AC100V-50Hz Connection between 1 and 2
	AC200V-50Hz
	AC100V-60Hz Connection between 1 and 3
	AC200V-60Hz
	AC110V-60Hz Connection between 1 and 2
	AC220V-60Hz

Dimension drawing

●RB*P

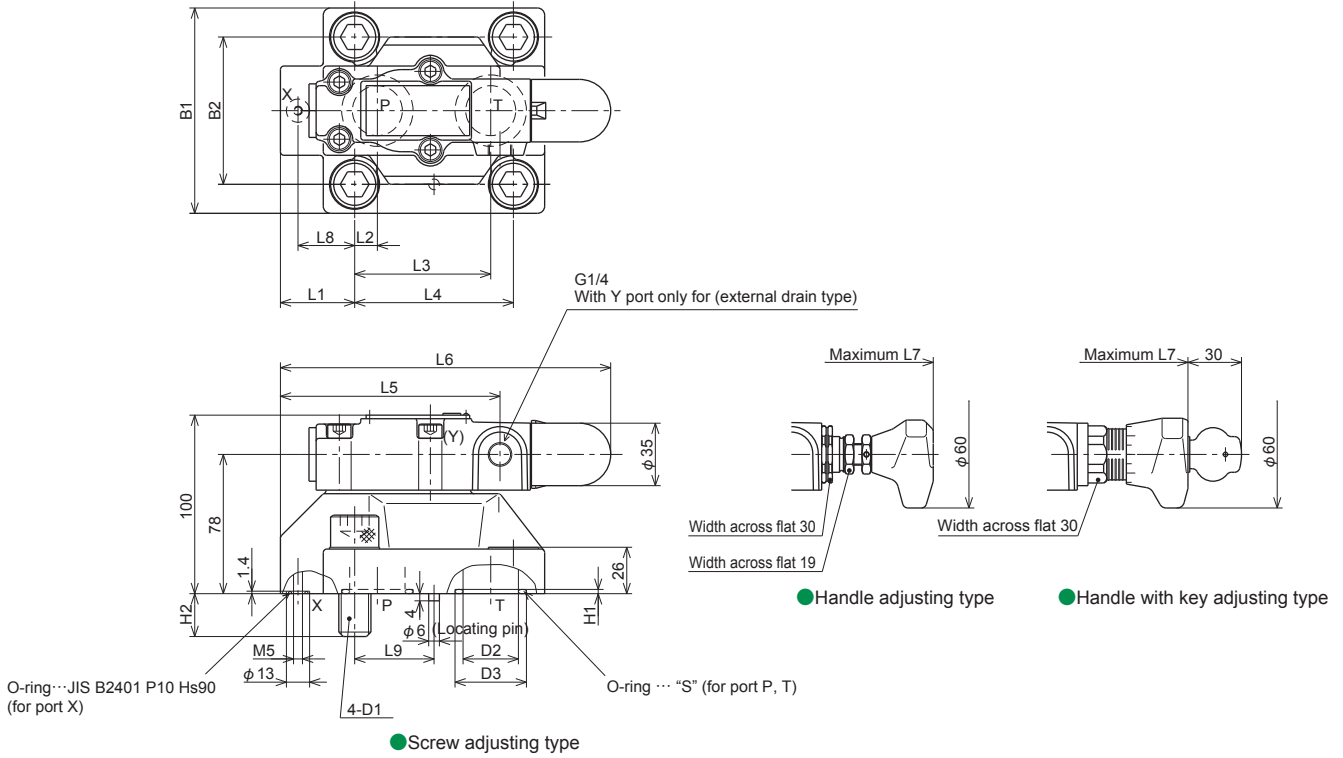

Nominal dimension	B1	B2	D1	D2	D3	L1	L2	L3	L4	L5	L6	L7	L8	L9	H1	H2	O-ring dimension "S"
10	78	54	4-M12	12	20	23.5	22.2	47.6	54	99.5	156.5	179	0	22.1	1.8	19	2-JIS B2401 P16 Hs90
20	100	69.8	4-M16	25	35	34	11.1	55.5	66.7	113	168	193	23.8	33.3	2.4	24	2-JIS B2401 G30 Hs90
30	115	82.5	4-M18	31	40	41.5	12.7	76.2	89	123	179	203	31.7	44.4	2.4	24	2-JIS B2401 G35 Hs90

Relief valve – Balanced piston type pilot operated (1)

●RB₃₀¹⁰C

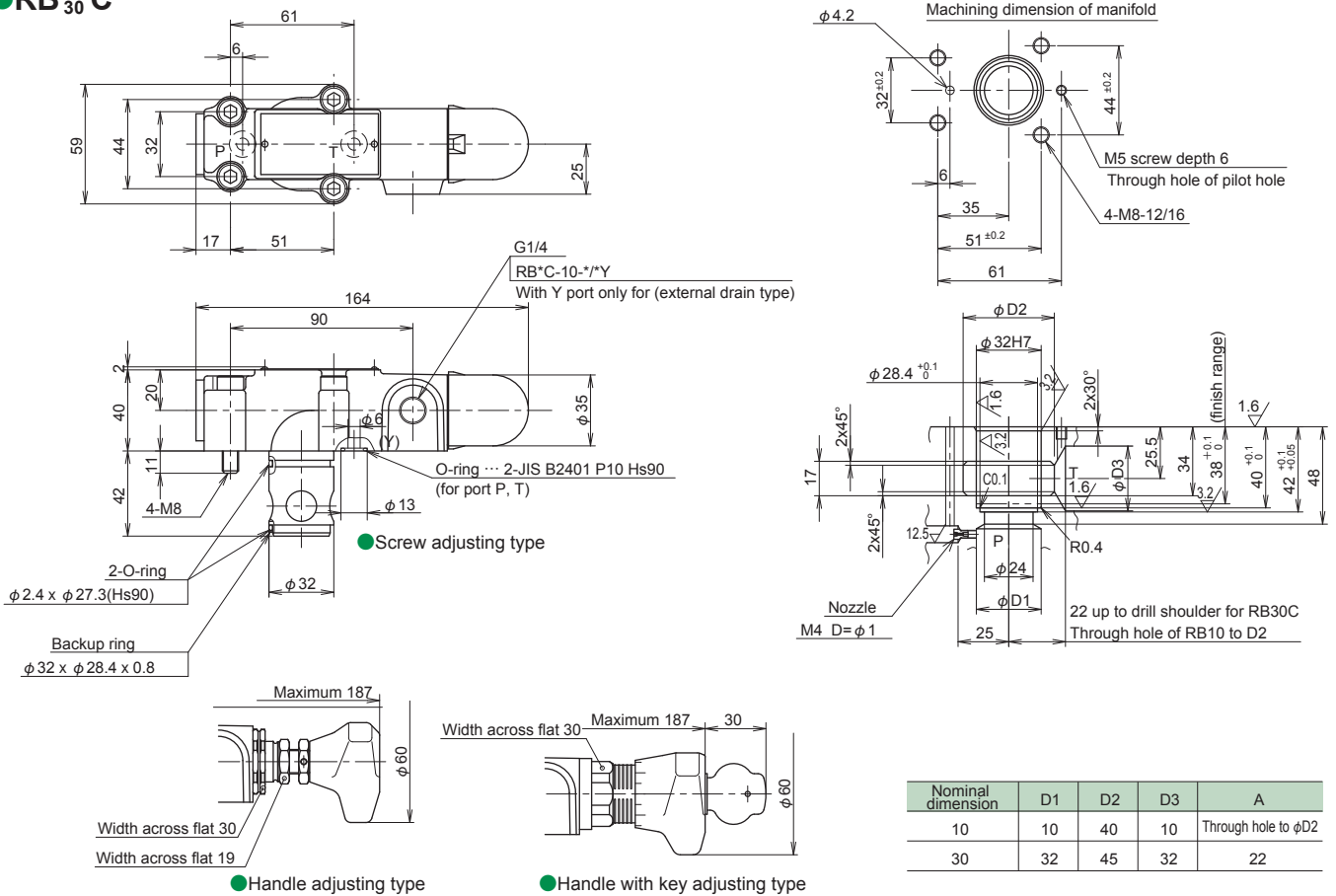

Nominal dimension	D1	D2	D3	A
10	10	40	10	Through hole to $\phi D2$
30	32	45	32	22

RBE*P

This diagram shows a case with a shock damping valve. In the case without a shock damping valve, this dimension is 0.

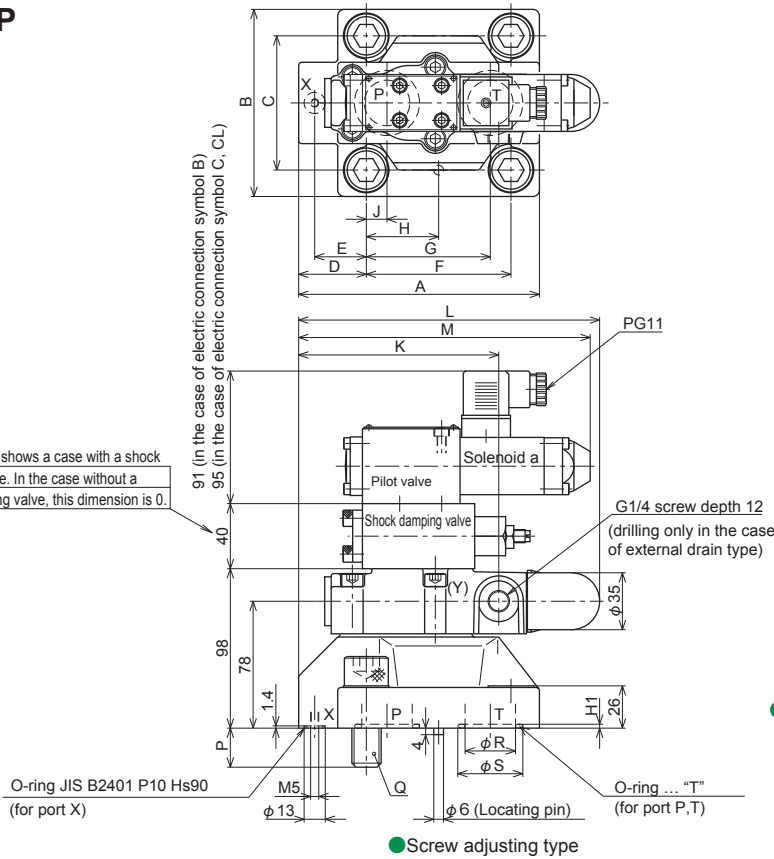

Nominal dimension	A	B	C	D	E	F	G	H	H1	J	K	L	M	N	P	Q	R	S	O-ring dimension "T"
10	90	78	54	23.5	0	54	47.5	22.1	1.8	22.1	99.5	156.5	155.7	179.5	19	4-M12	12	20	2-JIS B2401 P16 Hs90
20	117	100	69.8	34	23.8	66.7	55.6	33.3	2.4	11.1	112.7	169.7	168.9	192.7	24	4-M16	25	35	2-JIS B2401 G30 Hs90
30	148	115	82.5	41.5	31.7	88.9	76.2	44.4	2.4	12.7	122.9	179.9	179.1	202.9	24	4-M18	31	40	2-JIS B2401 G35 Hs90

RBE¹⁰₃₀C

This diagram shows a case with a shock damping valve. In the case without a shock damping valve, this dimension is 0.

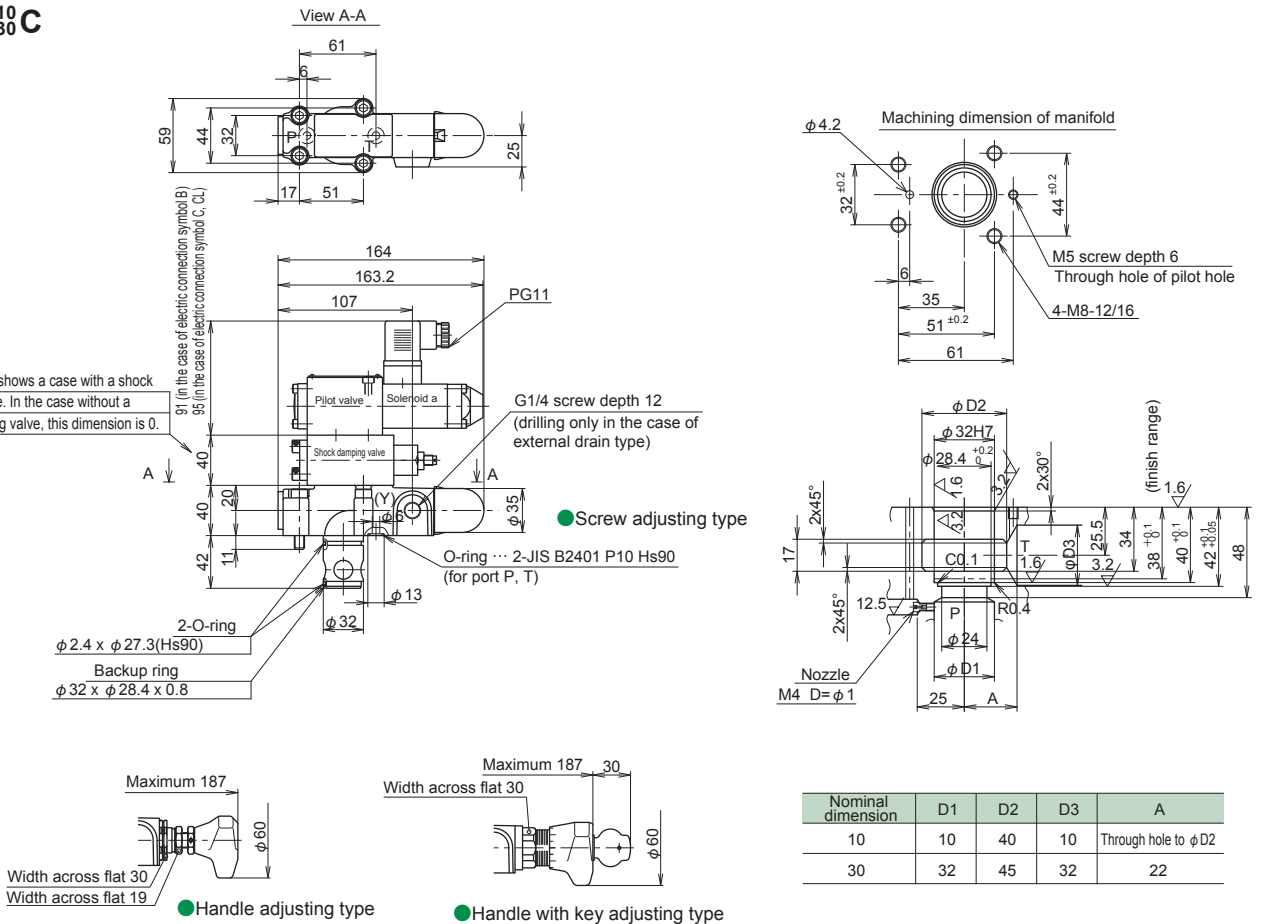

Nominal dimension	D1	D2	D3	A
10	10	40	10	Through hole to φD2
30	32	45	32	

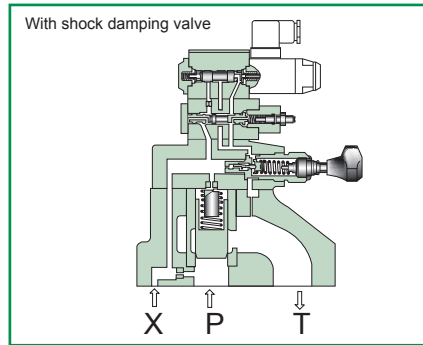
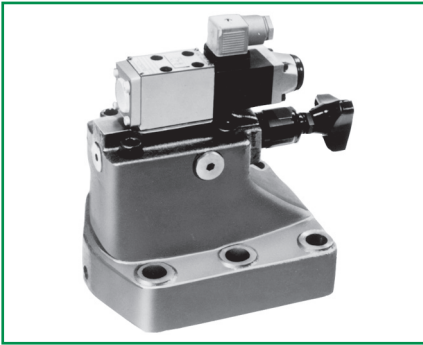

Overview

This balanced piston type pilot operated relief valve, which is a seat type relief valve, regulates the highest pressure of the hydraulic circuit and at the same time prevents overload of the hydraulic equipment and drive machines and sets pressure for control of the hydraulic equipment. The relief valve with unloading function is used for loading and unloading the circuit pressure with electrical signals.

Features

1. As this valve has a larger seat diameter than that of a general balance type relief valve, it has good responsiveness and flow resistance when unloaded is small.
2. Pressure override is small.
3. Operation is correct and both responsiveness and stability are good.
4. The relief valve with unloading function can perform shockless, smooth unloading if it is

used together with the shock damping valve (refer to the section of the type number index "ZNS5").

5. As this valve adopts an unequal type plunger, it opens when T port is pressurized.

Type indication

●RB

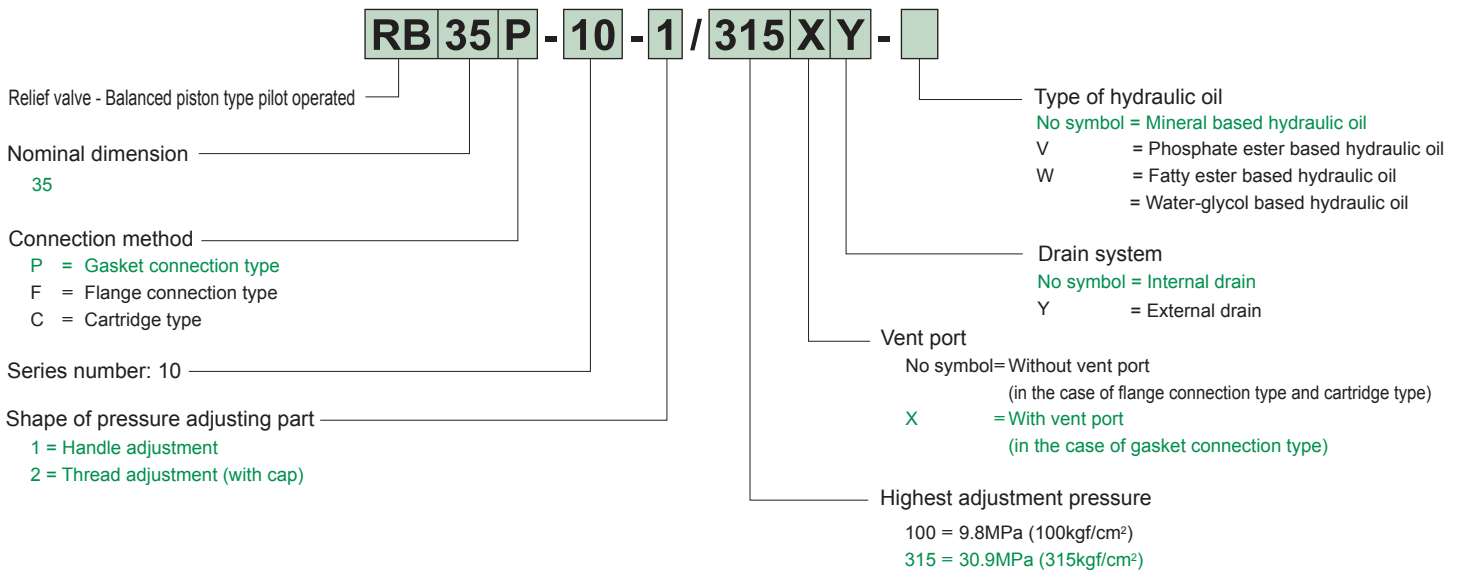

●Hydraulic symbols

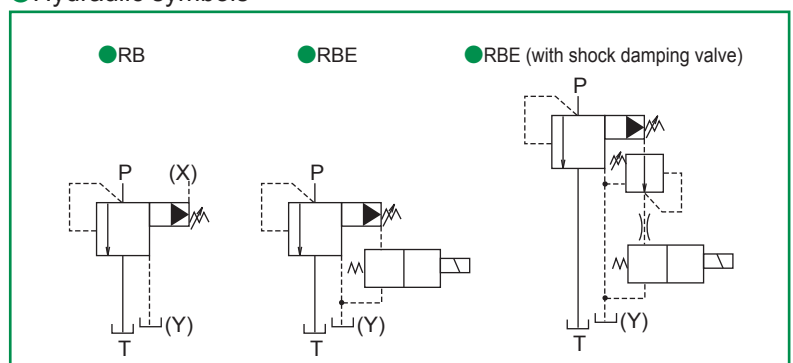

RBE

RBE 35 P - 10 - B 1 / 315 X Y - W D 24 CL - S -

Relief valve
- Balanced piston type pilot operated
(with solenoid valve)

Nominal dimension
35

Connection method
P = Gasket connection type
F = Flange connection type
C = Cartridge type

Series number: 10

Vent port

A = Normal close



B = Normal open



Shape of pressure adjusting part

1 = Handle adjustment
2 = Thread adjustment (with cap)

Highest adjustment pressure

100 = 9.8MPa (100kgf/cm²)
315 = 30.9MPa (315kgf/cm²)

Vent port

No symbol = Without vent port (in the case of flange connection type and cartridge type)
X = With vent port (in the case of gasket connection type)

Drain system

No symbol = Internal drain
Y = External drain

Type of hydraulic oil

No symbol = Mineral based hydraulic oil
V = Phosphate ester based hydraulic oil
W = Fatty ester based hydraulic oil
W1 = Water-glycol based hydraulic oil

Shock damping valve provided or not
No symbol = Without shock damping valve
S = With shock damping valve

Electric connection symbol

symbol	Explanation	Input power supply		
		A	D	R
B	With DIN connector	○	○	—
C	With DIN large connector	○	○	○
CL	With DIN large connector with lamp	○	○	—

Input voltage

12 = 12V
24 = 24V
100 = 100V
200 = 200V

*For details of voltage specifications, refer to "Solenoid specifications" of the solenoid operated directional valve "DE5".

*For other power supply, please contact us.

Input power supply

A = Alternating current
D = Direct current
R = AC/DC conversion

Solenoid type

W = Wet type
(with standard emergency manual operation)

Specifications

Nominal dimension		35	
Maximum working pressure MPa (kgf/cm ²)	Port P, T, X	30.9 (315)	(Note1)
	Port Y	RB	30.9 (315)
RBE		15.7 (160)	
Maximum flow rate	L/min	800	
Highest adjustment pressure	MPa (kgf/cm ²)	9.8 (100) or 30.9 (315)	
Type of solenoid operated directional valve (Note 2)		Equivalent to DE5P-2 ⁰¹ / ₀₂	
Type of shock damping valve (Note 3)		ZNS5-1	
Pilot valve type (Note 4)		RD6C	
Mass kg	RB	17	
	RBE	19	

(Note 1) However, the maximum working pressure of port T is 15.7 MPa (160 kgf/cm²) in the case of RBE internal drain type.

(Note 2) Refer to the section of the solenoid operated directional valve "DE5".

(Note 3) Refer to the section of the type number index "ZNS5" for the specifications.

(Note 4) Refer to the section of the type number index "RD6C".

Pressure override characteristics

(viscosity 36 mm²/s (cSt))

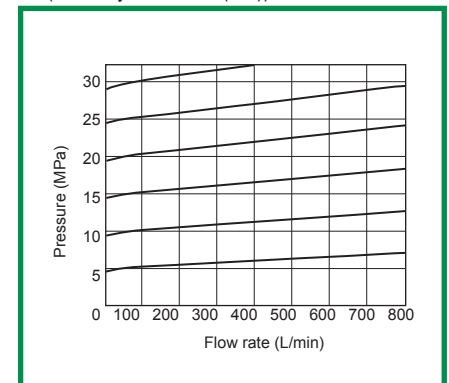

Minimum adjustment pressure characteristics (viscosity 36 mm²/s (cSt))

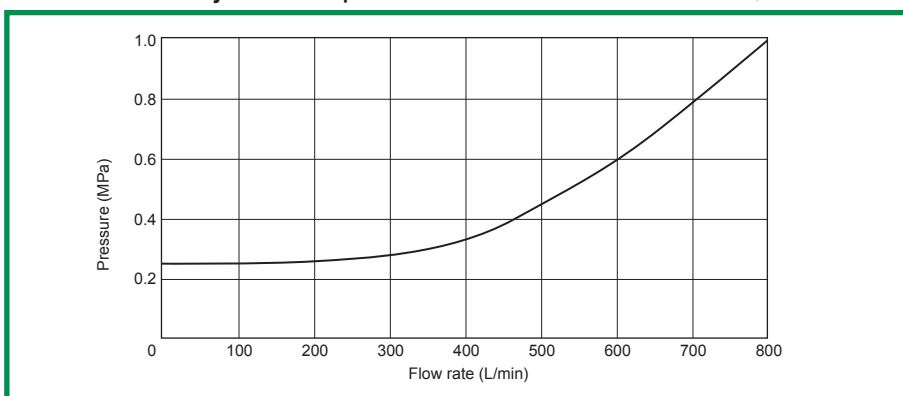

Type indication

RB35X

RB35X - 1 - 10 / 315 Y -

Pilot relief valve
for RB35

Series number: 10

Shape of pressure adjusting part

- 1 = Handle adjustment
- 2 = Thread adjustment (with cap)

Type of hydraulic oil

- No symbol = Mineral based hydraulic oil
- V = Phosphate ester based hydraulic oil
- W = Fatty ester based hydraulic oil
- Water-glycol based hydraulic oil

Drain system

- No symbol = Internal drain
- Y = External drain

Highest adjustment pressure

- 100 = 9.8MPa (100kgf/cm²)
- 315 = 30.9MPa (315kgf/cm²)

RBE35X

RBE35X - 10 - B 1 / 315 Y - W D 24 CL - S -

Pilot relief valve
for RB35

Series number: 10

Vent circuit

A = Normal close

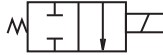

B = Normal open

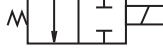

Shape of pressure adjusting part

- 1 = Handle adjustment
- 2 = Thread adjustment (with cap)

Highest adjustment pressure

- 100 = 9.8MPa (100kgf/cm²)
- 315 = 30.9MPa (315kgf/cm²)

Drain system

- No symbol = Internal drain
- Y = External drain

Type of hydraulic oil

- No symbol = Mineral based hydraulic oil
- V = Phosphate ester based hydraulic oil
- W = Fatty ester based hydraulic oil
- W1 = Water-glycol based hydraulic oil

Shock damping valve provided or not

- No symbol = Without shock damping valve
- S = With shock damping valve

Electric connection symbol

symbol	Explanation	Input power supply		
		A	D	R
B	With DIN connector	○	○	—
C	With DIN large connector	○	○	○
CL	With DIN large connector with lamp	○	○	—

Input voltage

- 12 = 12V
- 24 = 24V
- 100 = 100V
- 200 = 200V

*For other power supply, please contact us.

Input power supply

- A = Alternating current
- D = Direct current
- R = AC/DC conversion

Solenoid type

- W = Wet type (with standard emergency manual operation)

Accessories

Mounting bolt

Type	Hexagon socket head cap thread	Quantity	Tightening torque N·m (kgf·cm)
RB (E) 35P	M16×70L	6 pcs.	235.0 ± 35.2 (2400 ± 360)

Flange

Valve type	Maximum working pressure	Flange type	Connection diameter	Mass
RB (E) 35F	20.6MPa	TFAA-40	2B	2.6kg
	30.9MPa	TFXA-40	2B	2.7kg

When you use a flange, please place an order for the above flange type. For the dimension drawing, refer to page 16 of the appendix.

Dimension drawing

●RB35P

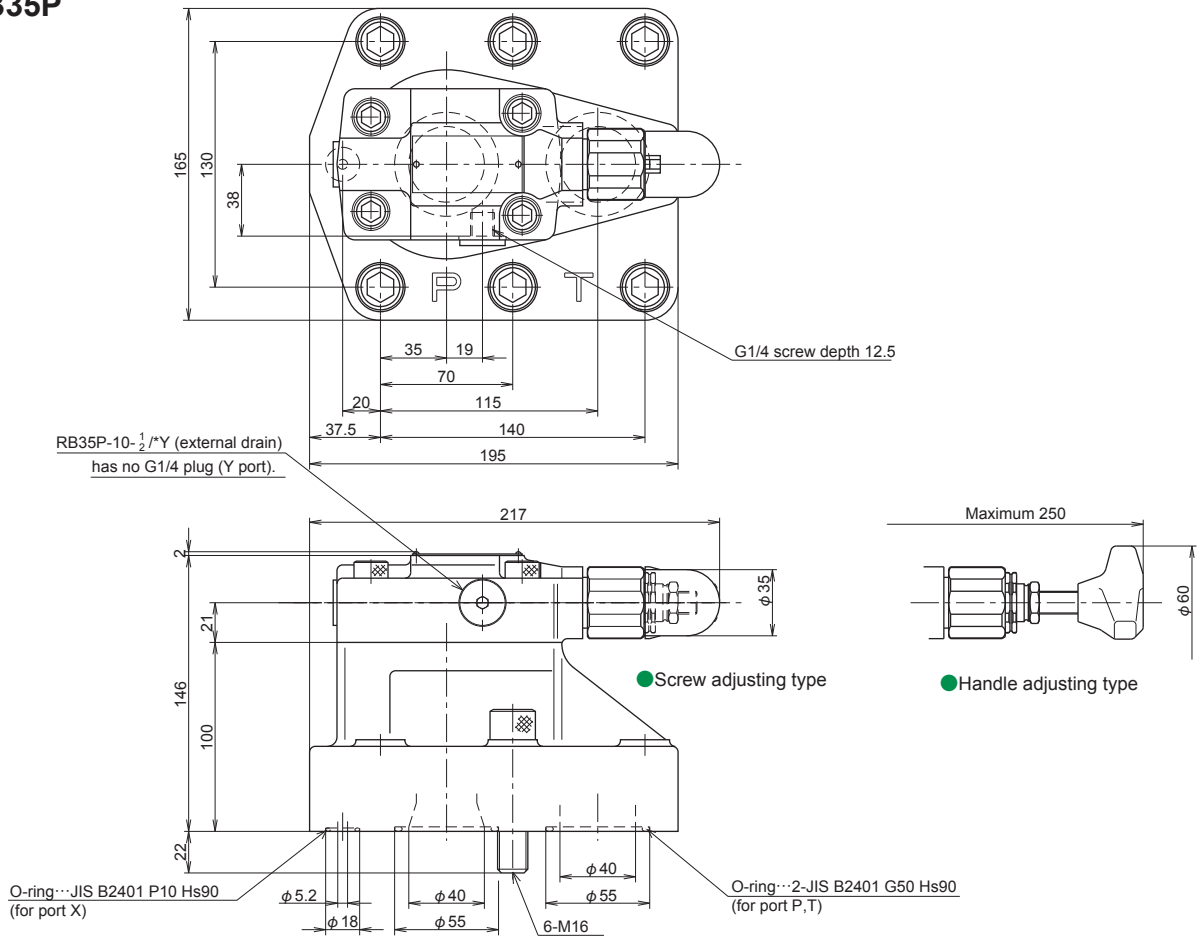

●RBE35P

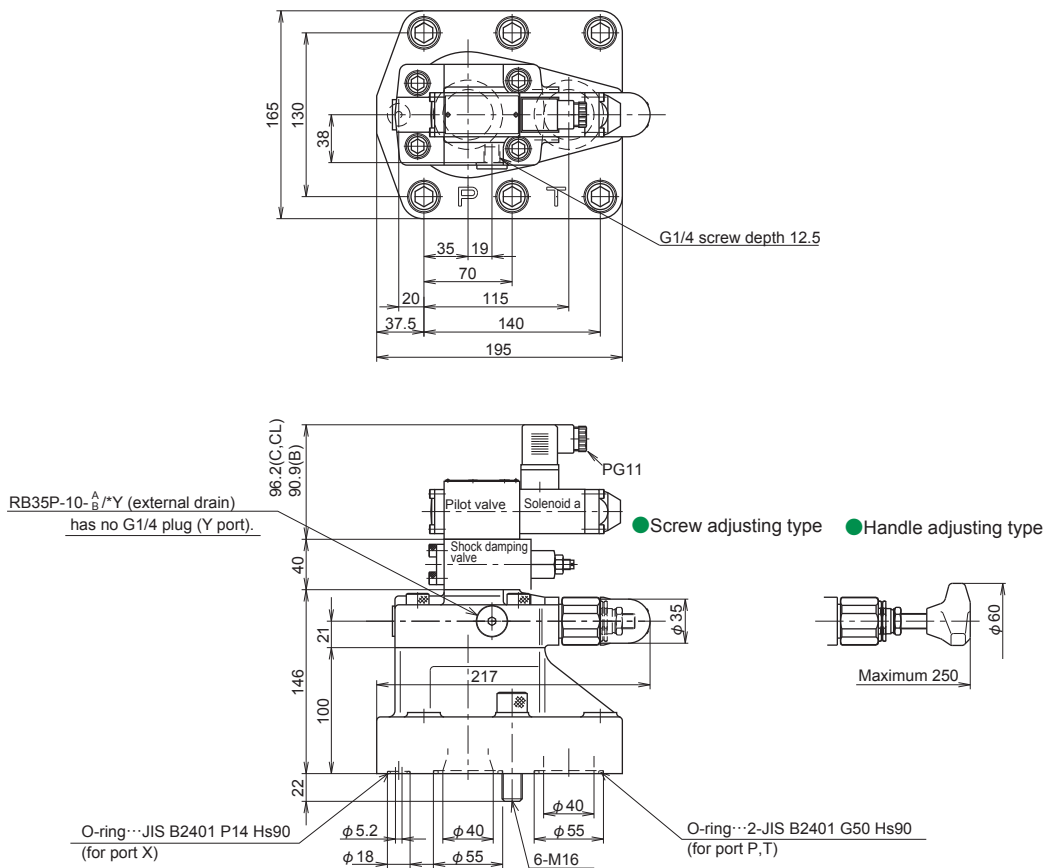

●RB35F

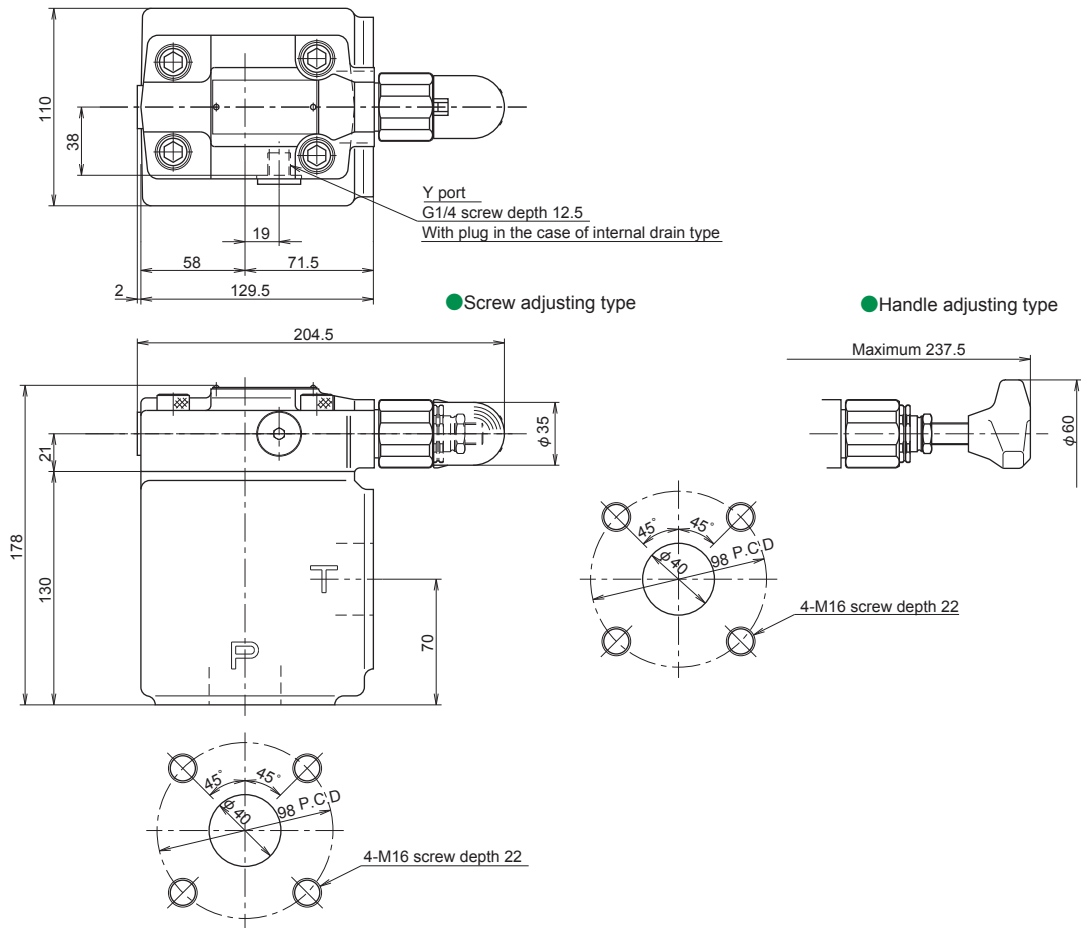

●RBE35F

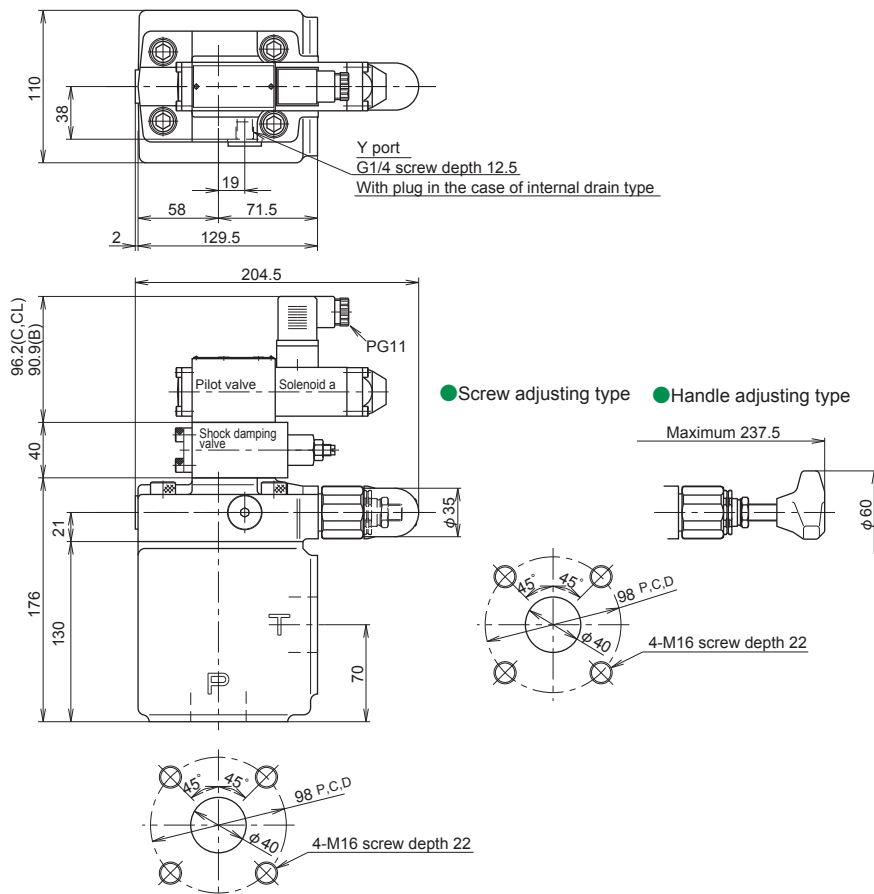

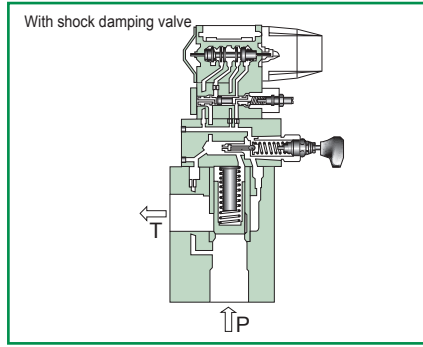
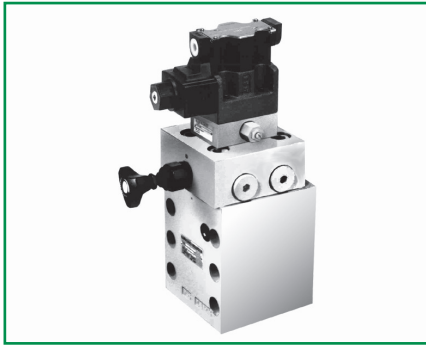

Overview

This balanced piston type pilot operated relief valve, which is a seat type relief valve, regulates the highest pressure of the hydraulic circuit and at the same time prevents overload of the hydraulic equipment and drive machines and sets pressure for control of the hydraulic equipment. The relief valve with unloading function is used for loading and unloading of the circuit pressure with electrical signals.

Features

- As this valve has a larger seat diameter than that of a general balance type relief valve, it has good responsiveness and flow resistance when unloaded is small.
- Pressure override is small.
- Operation is correct and both responsiveness and stability are good.
- The relief valve with unloading function can perform shockless, smooth unloading if it is used together with the shock damping valve (refer to the section of the type number index "ZNS10").

Hydraulic symbols

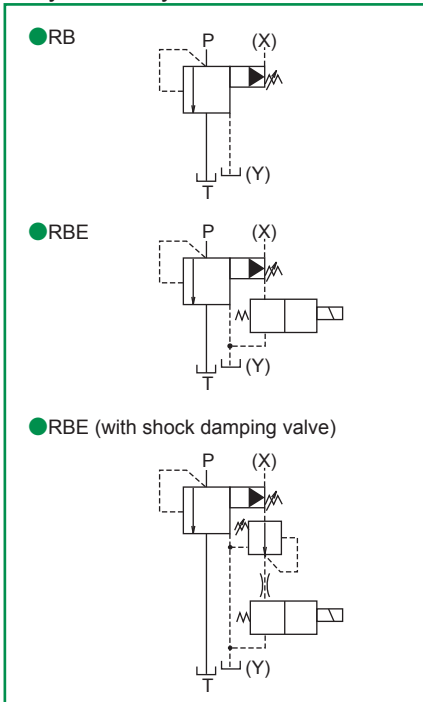

Specifications

Nominal dimension		52	82	
Maximum working pressure MPa (kgf/cm ²)	Port P, X	30.9 (315)		
	Port T	RB	30.9 (315)	
		RBE	External drain	30.9 (315)
	Internal drain		16 (163) (Note 3)	
	Port Y	RB	30.9 (315)	
RBE		16 (163) (Note 3)		
Maximum flow rate	L/min	1,500	3,500	
Highest adjustment pressure MPa(kgf/cm ²)		9.8 (100) or 30.9 (315)		
Type of solenoid operated directional valve (Note 1)	Cartridge type	DE10P-20-204-W*		
Type of shock damping valve (Note 2)		ZNS10-1		
Pilot relief valve type		RDV10C		
Mass kg	RB	Gasket connection type	37	88
		Flange connection type	37	46
	RBE	Gasket connection type	41	92
		Flange connection type	41	50

(Note 1) Refer to the section of the type number index "DE10P" for the specifications.
 (Note 2) Refer to the section of the type number index "ZNS10" for the specifications.
 (Note 3) The maximum working pressure for port T and Y is limited by the specifications of DE10P.

● The direct operated type relief valve RDV10C*¹⁰⁰/₃₁₅-1.5 is used for the pressure adjusting part of the pilot valve. For the pressure increase value per turn of the adjust thread, refer to the section of the type number index "RD10".

Type indication

●RB52

RB 52 P - 10 - 1 / 315 X Y -

Relief valve- Balanced piston type pilot operated

Nominal dimension

52, 82

Connection method

- P = Gasket connection type
- F = Flange connection type
- C = Cartridge type

Series number: 10

Shape of pressure adjusting part

- 1 = Handle adjustment
- 2 = Thread adjustment (with cap)
- 3 = Handle with key adjustment

Type of hydraulic oil

- No symbol = Mineral based hydraulic oil
- V = Phosphate ester based hydraulic oil
- W = Fatty ester based hydraulic oil
- Water-glycol based hydraulic oil

Drain system

- No symbol = Internal drain
- Y = External drain

Vent port

- No symbol = Without vent port
- X = With vent port
(gasket connection type is X only)

Highest adjustment pressure

- 100 = 9.8MPa (100kgf/cm²)
- 315 = 30.9MPa (315kgf/cm²)

●RBE52

RBE 52 P - 20 - B 1 / 315 X Y - W D 24 AL - S -

Relief valve

- Balanced piston type pilot operated (with solenoid valve)

Nominal dimension

52, 82

Connection method

- P = Gasket connection type
- F = Flange connection type
- C = Cartridge type

Series number

Vent circuit

A = Normal close



B = Normal open



Shape of pressure adjusting part

- 1 = Handle adjustment
- 2 = Thread adjustment (with cap)
- 3 = Handle with key adjustment

Highest adjustment pressure

- 100 = 9.8MPa (100kgf/cm²)
- 315 = 30.9MPa (315kgf/cm²)

Vent port

- No symbol = Without vent port
- X = With vent port (gasket connection type is X only)

Drain system

- No symbol = Internal drain
- Y = External drain

Type of hydraulic oil

- No symbol = Mineral based hydraulic oil
- V = Phosphate ester based hydraulic oil
- W = Fatty ester based hydraulic oil
- Water-glycol based hydraulic oil

Shock damping valve provided or not

- No symbol = Without shock damping valve
- S = With shock damping valve

Electric connection symbol

- AL = Center terminal with lamp

Input voltage

- 12 = 12V
- 24 = 24V
- 100 = 100V
- 200 = 200V

*For other power supply, please contact us.

Input power supply

- A = Alternating current
- D = Direct current
- R = AC/DC conversion

Solenoid type

- W = Wet type (with standard emergency manual operation)

* (For the explosion proof type, please contact us.)

*For details, refer to the section of the solenoid operated directional valve "DE10".

Flange

Valve type	Maximum working pressure	Flange type	Connection diameter	Mass
RB (E) 52F	20.6MPa	TFAA-40	2B	2.6kg
	30.9MPa	TFXA-40	2B	2.7kg
RB (E) 82F	20.6MPa	TFAA-63	3B	3.9kg
	30.9MPa	TFXA-63	3B	4.5kg

When you use a flange, please place an order for the above flange type.
For the dimension drawing, refer to page 16 of the appendix.

Accessories

● Mounting bolt

Type	Hexagon socket head cap thread	Quantity	Tightening torque N·m (kgf·cm)
RB (E) 52P	M16×150L	6 pcs.	235.2 ± 35.2 (2400 ± 360)
RB (E) 82P	M20×200L	6 pcs.	431.2 ± 64.6 (4400 ± 660)

Pressure override characteristics (viscosity 36 mm²/s(cSt))

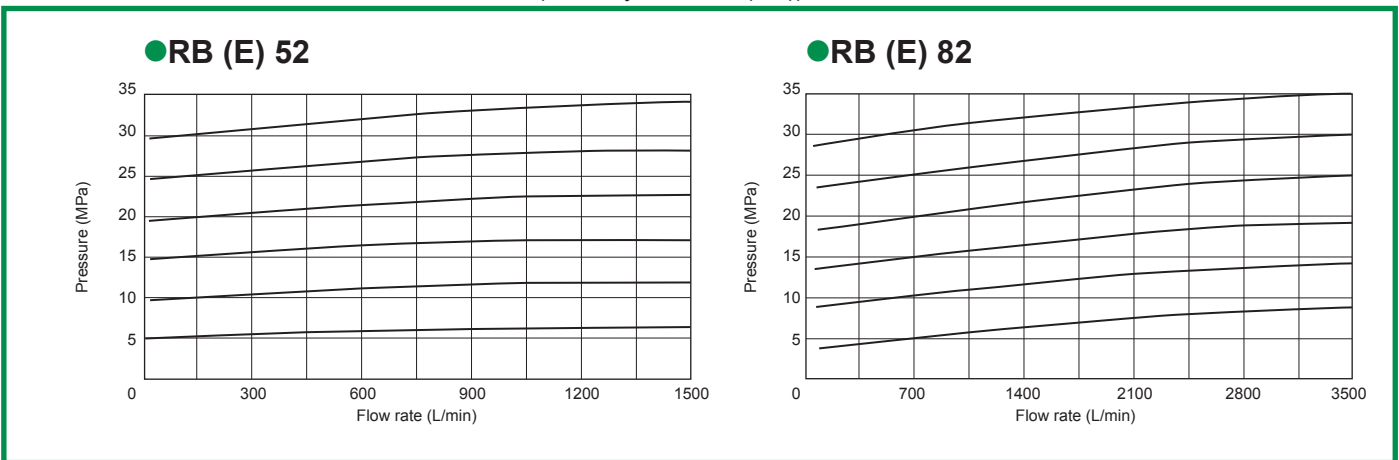

Minimum adjustment pressure characteristics (viscosity 36 mm²/s(cSt))

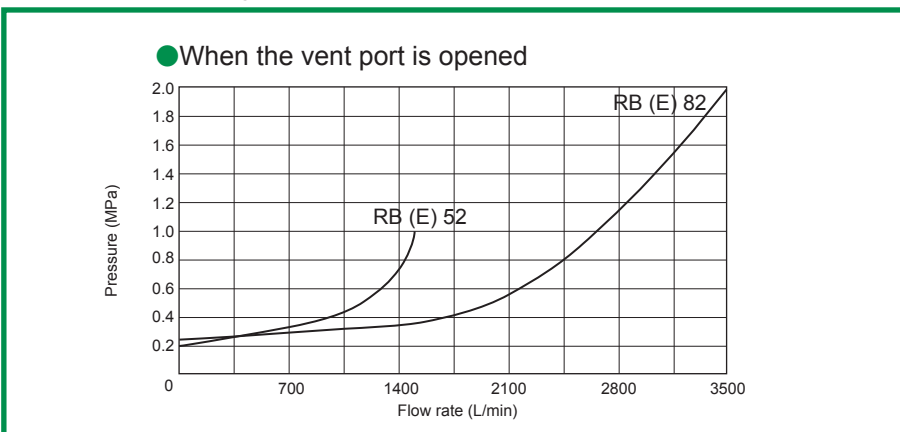

Pilot valve

- The type indication of the pilot valve used for the relief valve – balanced piston type pilot operated is as follows.
If you need the pilot valve only, please specify "pilot valve type" and contact us.

RB52X

RB 52 X - 10 - 1 / 315 X Y -

Pilot relief valve
For RB52, 82

Series number

Shape of pressure adjusting part
1 = Handle adjustment
2 = Thread adjustment (with cap)
3 = Handle with key adjustment

Highest adjustment pressure
100 = 9.8MPa (100kgf/cm²)
315 = 30.9MPa (315kgf/cm²)

Type of hydraulic oil

No symbol = Mineral based hydraulic oil
V = Phosphate ester based hydraulic oil
W = Fatty ester based hydraulic oil
Water-glycol based hydraulic oil

Drain system

No symbol = Internal drain
Y = External drain

Vent port

No symbol = Without vent port
X = With vent port

RBE52X

RBE52X - 20 - B 1 / 315 X Y - WD 24 AL - S -

Pilot relief valve
For RBE52, 82

Series number

Vent circuit

A = Normal close

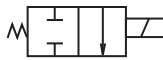

B = Normal open



Shape of pressure adjusting part
1 = Handle adjustment
2 = Thread adjustment (with cap)
3 = Handle with key adjustment

Highest adjustment pressure
100 = 9.8MPa (100kgf/cm²)
315 = 30.9MPa (315kgf/cm²)

Vent port
No symbol = Without vent port
X = With vent port

Drain system

No symbol = Internal drain
Y = External drain

Type of hydraulic oil

No symbol = Mineral based hydraulic oil
V = Phosphate ester based hydraulic oil
W = Fatty ester based hydraulic oil
Water-glycol based hydraulic oil

Shock damping valve provided or not

No symbol = Without shock damping valve
S = With shock damping valve

Electric connection symbol

AL = Center terminal with lamp

Input voltage

12 = 12V
24 = 24V
100 = 100V
200 = 200V

*For other power supply, please contact us.

Input power supply

A = Alternating current
D = Direct current
R = AC/DC conversion

Solenoid type

W = Wet type (with standard emergency manual operation)

* (For the explosion proof type, please contact us.)

*For details, refer to the section of the solenoid operated directional valve "DE10".

Dimension drawing

RBE**F

(Note) This diagram shows the type RBE*. In the case of the type RB*, there are no shock damping valve and solenoid operated directional valve.

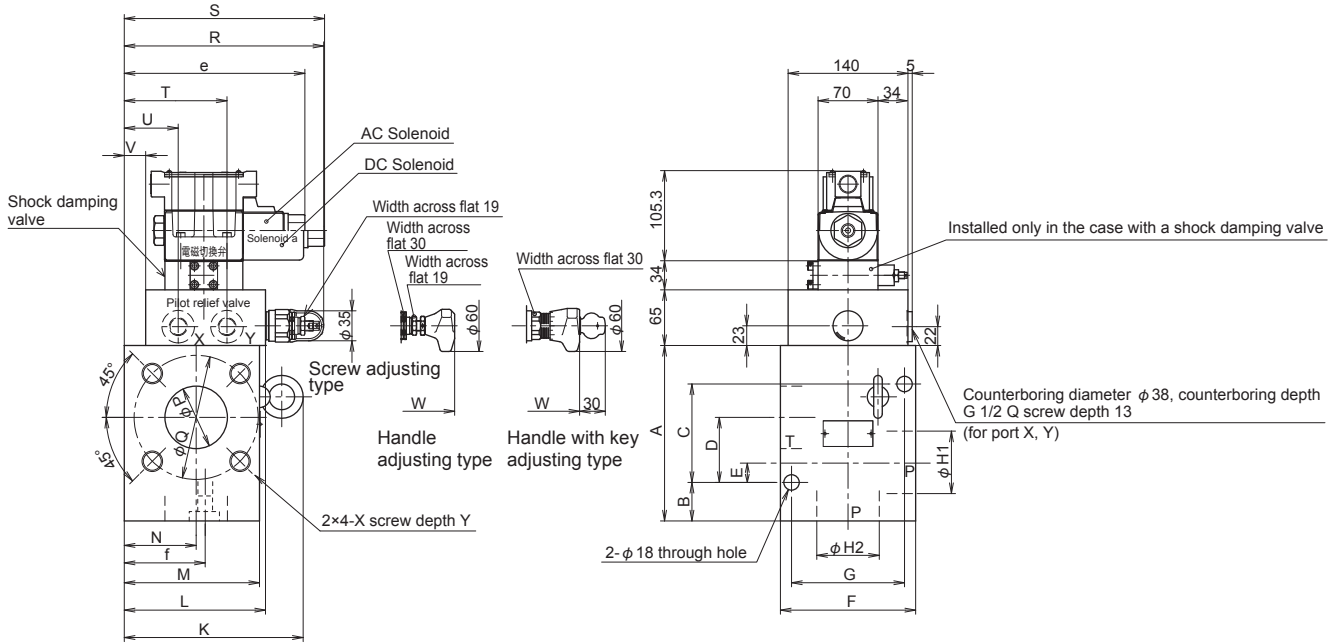

(Note) The P port position is H1 in the case of RBE52F and H2 in the case of 82F.

Nominal dimension	A	B	C	D	E	F	G	H1	H2	K	L	M	N	P	Q	R	S	T	U	V	W	e	f
52	185	35	100	77	25	148	115	45	—	199	156	148	74	45	98	224	225	111	54	16	247	202	84
82	205	45	115	76	—	158	132	—	73	209	165	158	84	26	145	233	234	120	63	25	268	211	—
Nominal dimension	X	Y																					
52	M16	24																					
82	M24	36																					

Relief valve — Balanced piston type pilot operated (3)

RBE**P

(Note) This diagram shows the type RBE*. In the case of the type RB*, there are no shock damping valve and solenoid operated directional valve.

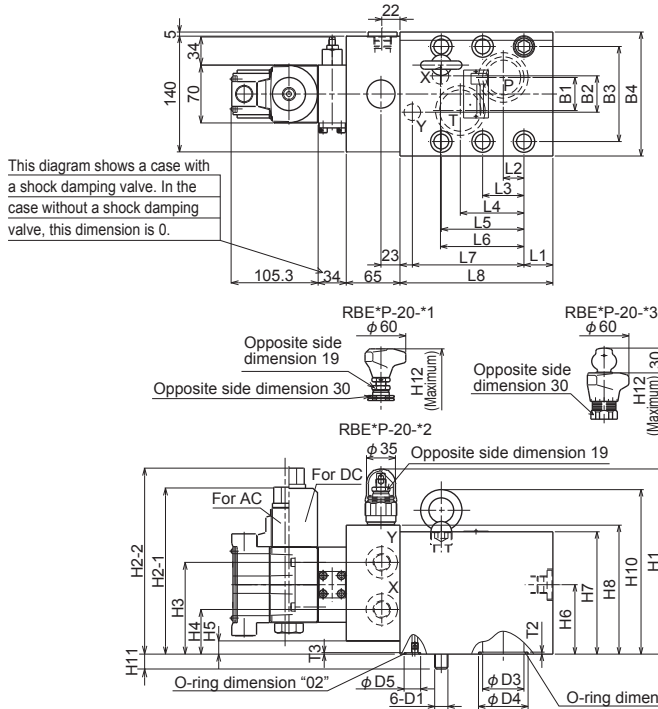

This diagram shows a case with a shock damping valve. In the case without a shock damping valve, this dimension is 0.

Hydraulic symbols

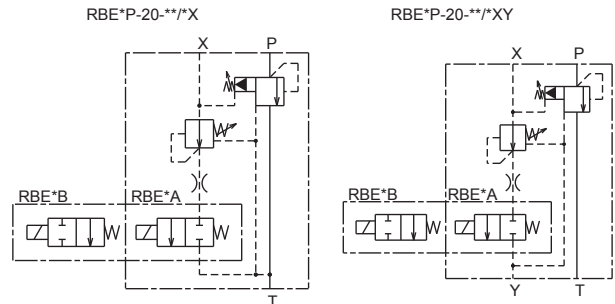

Nominal dimension	B1	B2	B3	B4	D1	D3	D4	D5	H1	H2-1	H2-2	H3	H4	H5	H6	H7	H8	H10	H11	H12	L1	L2	L3
RBE52	40	44	115	150	M16	50	60	20	224	202	225	111	54	16	84	148	156	199	18	250	35	25	50
RBE82	50	60	170	210	M20	80	90	30	254	232	255	141	84	46	105	210	186	261	25	280	50	30	70
Nominal dimension	L4	L5	L6	L7	L8	T2	T3	O-ring dimension "01"	O-ring dimension "02"														
RBE52	77	100	101	135	185	2.4	1.8	2-JIS B 2401 G55 Hs90	2-JIS B 2401 P16 Hs90														
RBE82	115	140	151	185	255	2.4	2.4	2-JIS B 2401 G85 Hs90	2-JIS B 2401 G25 Hs90														

Three stage pressure relief valve

3RBE

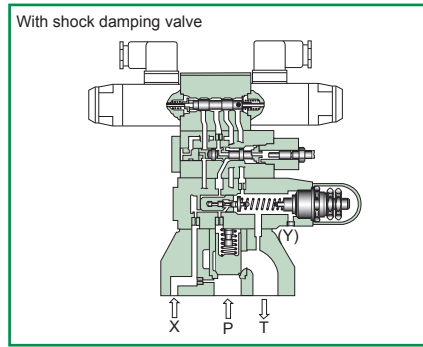
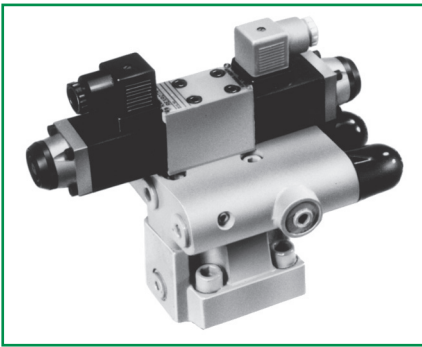

Overview

This three stage pressure relief valve is a balanced piston type pilot operated relief valve integrating three pilot relief valves and one solenoid operated directional valve into one body, and can control the circuit pressure at two or three stages with electrical signals to the solenoid operated directional valve.

Features

1. The circuit pressure can be controlled at two or three stages without vent connection.
2. Concurrent use of the shock damping valve (refer to the section of the type number index "ZNS5") can perform shockless, smooth pressure change.
3. Adoption of the unequal type for the main plunger has realized stable operation.

Type indication

3RBE10 P - 10 - 2 / 315XY - 05 W D 24 CL - S - L07 -

Three stage pressure relief valve

Nominal dimension

10, 20, 30

Connection method

P = Gasket connection type
C = Cartridge type

Series number: 10

Shape of pressure adjusting part

2 = Thread adjustment (with cap)

Highest adjustment pressure

100 = 9.8MPa (100kgf/cm²)
315 = 30.9MPa (315kgf/cm²)

Vent port

No symbol = Without vent port (in the case of flange connection type and cartridge type)

X = With vent port (in the case of gasket connection type)

Drain system

No symbol = Internal drain

Y = External drain

Spool type of solenoid operated directional valve

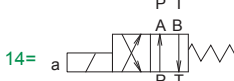

Type of hydraulic oil

No symbol = Mineral based hydraulic oil
V = Phosphate ester based hydraulic oil
W = Fatty ester based hydraulic oil
W1 = Water-glycol based hydraulic oil

Design No.

Shock damping valve provided or not

No symbol = Without shock damping valve
S = With shock damping valve

Electric connection symbol

Symbol	Explanation	Input power supply		
		A	D	R
B	With DIN connector	○	○	—
C	With DIN large connector	○	○	○
CL	With DIN large connector with lamp	○	○	—

Input voltage

12 = 12V
24 = 24V
100 = 100V
200 = 200V

* For details of voltage specifications, refer to "Solenoid specifications" of the solenoid operated directional valve "DE5".
* For other power supply, please contact us.

Input power supply

A = Alternating current
D = Direct current
R = AC/DC conversion

Solenoid type

W = Wet type
(with standard emergency manual operation)

● Hydraulic symbols

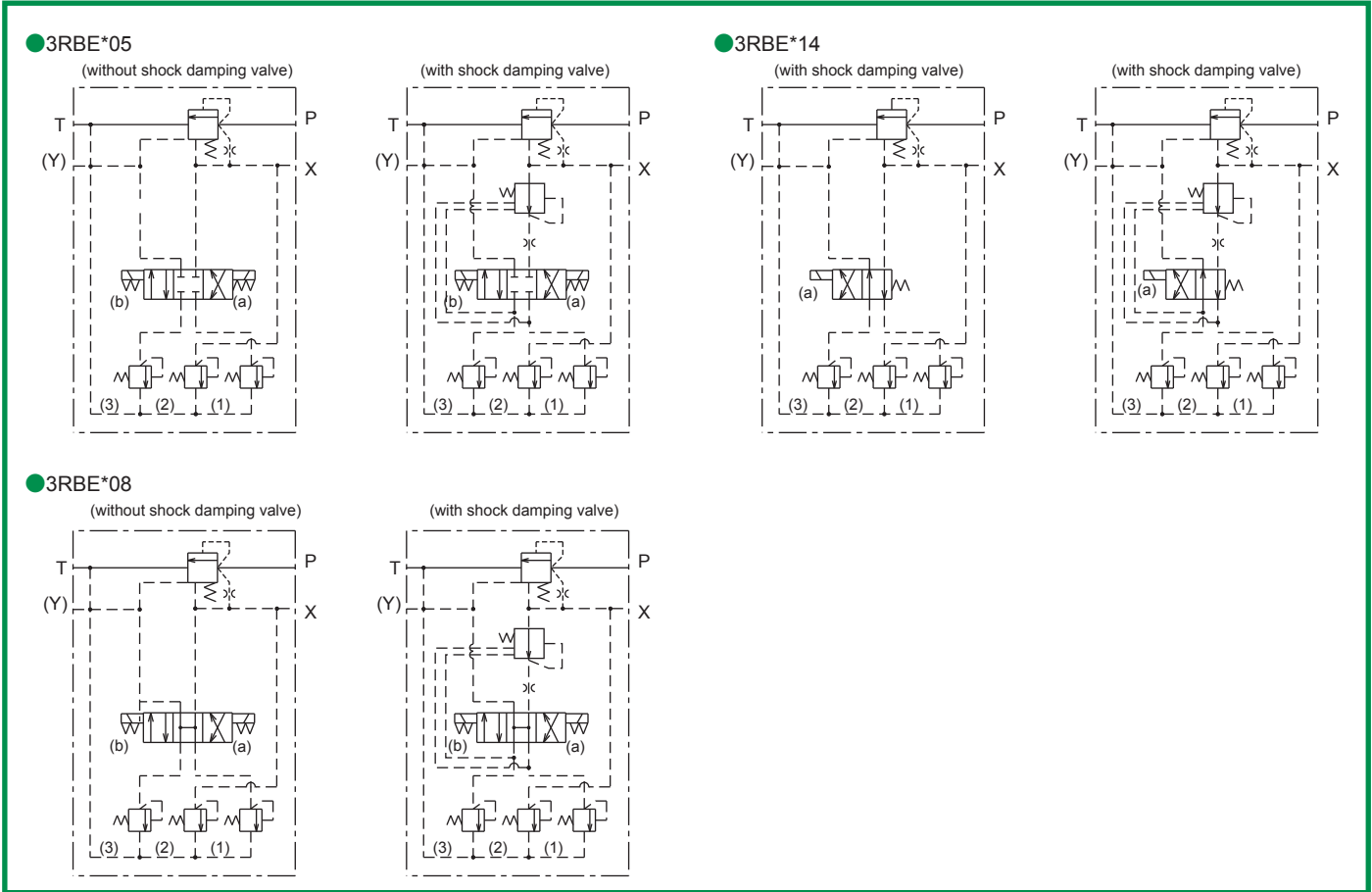

■ Specifications

Nominal dimension		10	20	30
Maximum working pressure MPa (kgf/cm ²)	Port P, T, X	30.9 (315) (Note1)		
	Port Y	5.9 (60)		
Maximum flow rate	L/min	200	400	600
Highest adjustment pressure MPa (kgf/cm ²)		9.8 (100) or 30.9 (315)		
Type of solenoid operated directional valve (Note 2)		DE5P-10-2 ⁰⁵ ₀₈ ¹⁴		
Type of shock damping valve (Note 3)		ZNS5-2		
Mass	kg	7.7	8.3	9.6

(Note 1) The maximum working pressure of port T is 15.7 MPa (160 kgf/cm²) in the case of internal drain type.

(Note 2) Refer to the section of the solenoid operated directional valve "DE5".

(Note 3) Refer to the section of the type number index "ZNS5" for the specifications.

■ Sub-plate

Valve type	Sub-plate type	Connection diameter	Mass
3RBE10	P-RB10R14-0	Rc 1/4	2.1kg
	P-RB10G14-0	G 1/4	
	P-RB10R38-0	Rc 3/8	
	P-RB10G38-0	G 3/8	
	P-RB10R12-0	Rc 1/2	
	P-RB10G12-0	G 1/2	
3RBE20	P-RB20R34-0	Rc 3/4	4.4kg
	P-RB20G34-0	G 3/4	
	P-RB20R1-0	Rc 1	
	P-RB20G1-0	G1	
3RBE30	P-RB30R54-0	Rc1 1/4	6.9kg
	P-RB30G54-0	G1 1/4	
	P-RB30R32-0	Rc1 1/2	
	P-RB30G32-0	G1 1/2	

When you use a sub-plate, please place an order for the above sub-plate type.
For the dimension drawing, refer to page 5, 6 of the appendix.

● Pressure increase value per turn (clockwise) of adjust thread MPa (kgf/cm²)

Highest adjustment pressure	Nominal dimension	10, 20, 30
	100	
315	14.1 (143.9)	

(Note) As the above value is a calculated value, there are slight variations in the product.

■ Pressure override characteristics/ Minimum adjustment pressure characteristics

● This is similar to that of the relief valve – direct operated type.
Refer to the section of the type number index "RB10, 20, 30".

■ Accessories

● Mounting bolt

Type	Hexagon socket head cap thread	Quantity	Tightening torque N·m (kgf·cm)
3RBE10	M12×45L	4 pcs.	98.0 ± 14.7 (1000 ± 150)
3RBE20	M16×50L	4 pcs.	235.2 ± 35.2 (2400 ± 360)
3RBE30	M18×50L	4 pcs.	333.2 ± 50.0 (3400 ± 510)

Dimension drawing

3RBE

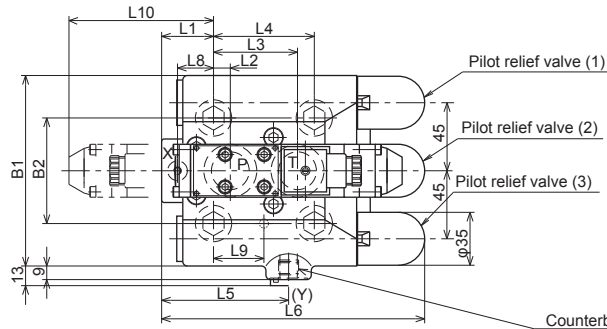

Counterboring diameter $\phi 25$,
 Counterboring depth 1
 Screw diameter, G1/4 screw depth 12
 (for port Y)
 (with plug in the case of internal drain type)

In the case of 3RBE*-⁰⁵/₀₈ (3 position valve)

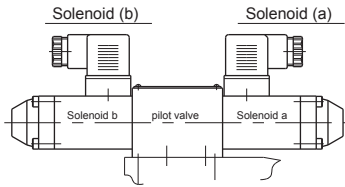

In the case of 3RBE*-14 (2 position valve)

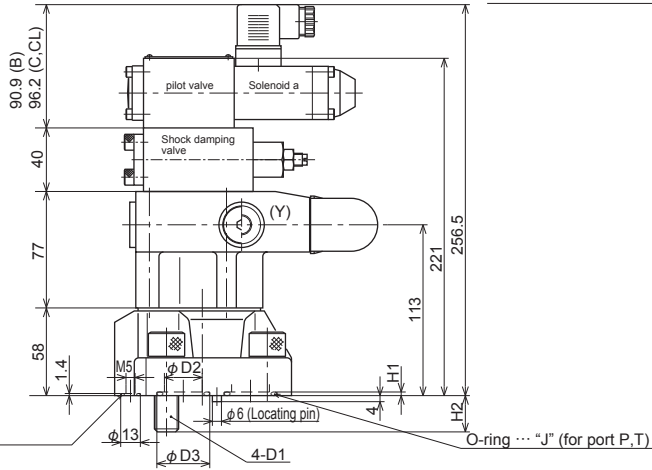

O-ring...JIS B2401 P10 Hs90
 (for port X)

O-ring ... "J" (for port P,T)

Nominal dimension	B1	B2	D1	D2	D3	L1	L2	L3	L4	L5	L6	L8	L9	L10	H1	H2	O-ring dimension "J"
10	126	54	4-M12	12	20	23.5	22.1	47.6	54	70.5	155.5	0	22.1	97.9	1.8	19	2-JIS B2401 P16 Hs90
20	126	69.8	4-M16	25	35	34	11.1	55.6	66.7	83.7	168.7	23.8	33.3	95.2	2.4	24	2-JIS B2401 G30 Hs90
30	126	82.5	4-M18	31	40	41.5	12.7	76.2	88.9	93.9	178.9	31.7	44.4	92.5	2.4	24	2-JIS B2401 G35 Hs90

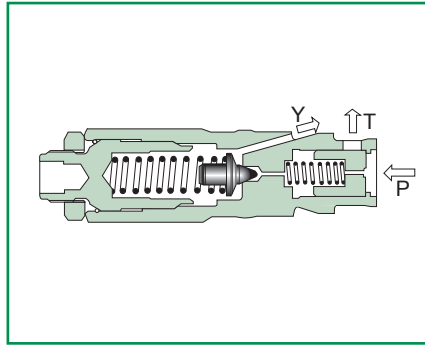

Relief valve – Balanced piston cartridge type pilot operated

Overview

This balanced piston type pilot operated, cartridge type relief valve regulates the highest pressure of the hydraulic circuit with a spool type relief valve to prevent overload of hydraulic equipment and drive machines. Besides, it is used to set the pressure for control of the hydraulic equipment.

Features

1. As this is a cartridge type, it can be incorporated in a manifold in a compact way.
2. Operation is correct and both responsiveness and stability are good.
3. Pressure override is small.

Type indication

RB1M 6 C - 10 - 4 / 100 -

Relief valve- Balanced piston type pilot operated

Nominal dimension
6, 10

Connection method
C = Cartridge type

Series number: 10

Type of hydraulic oil

- No symbol = Mineral based hydraulic oil
- Fatty ester based hydraulic oil
- Water-glycol based hydraulic oil
- V = Phosphate ester based hydraulic oil

Highest adjustment pressure

- 100 = 9.8MPa (100kgf/cm²)
- 315 = 30.9MPa (315kgf/cm²)

Shape of pressure adjusting part

- 4 = Thread adjustment (without cap)

Hydraulic symbols

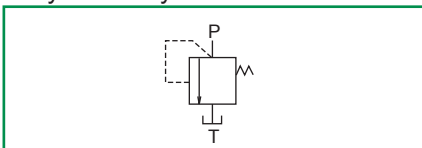

Specifications

Nominal dimension	6	10
Maximum working pressure MPa (kgf/cm ²)	30.9 (315)	
Maximum flow rate L/min	60	100
Mass kg	0.2	0.26

Pressure increase value per turn (clockwise) of adjust thread MPa (kgf/cm²)

Highest adjustment pressure \ Nominal dimension	6	10
100	2.57 (26.2)	2.57 (26.2)
315	12.9 (131.7)	12.9 (131.7)

(Note) As the above value is a calculated value, there are slight variations in the product.

Pressure override characteristics (viscosity 36mm²/s (cSt))

●RB1M6C

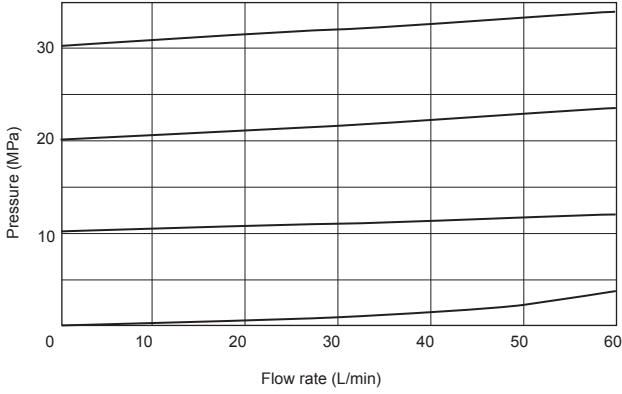

●RB1M10C

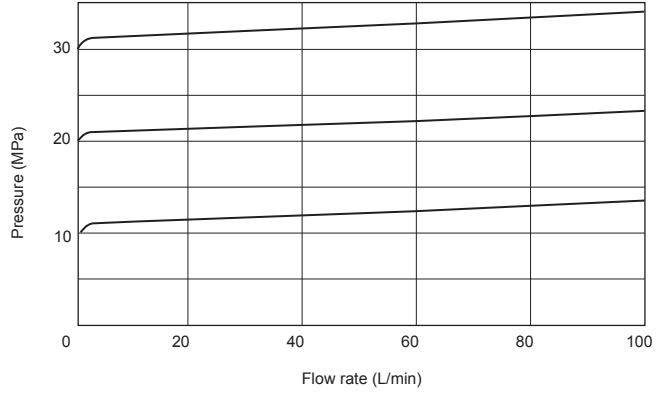

Dimension drawing

●RB1M*C

●Machining dimension of manifold

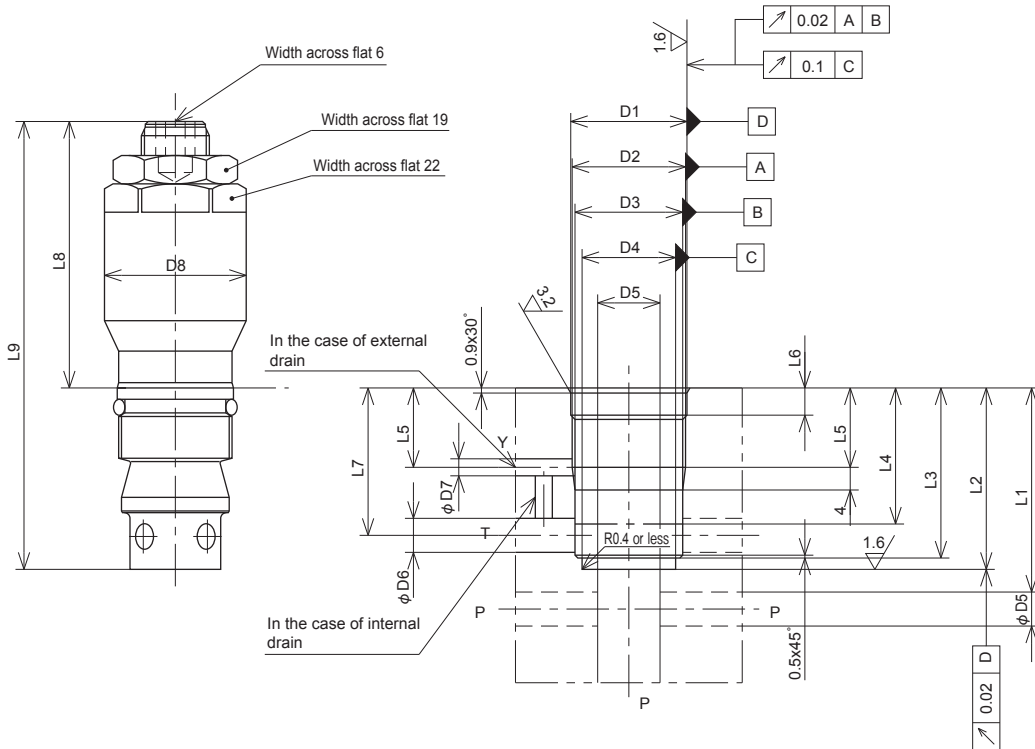

Nominal dimension	D1 ^{H7}	D2	D3 ^{H8}	D4 ^{+0.1}	D5 (maximum)	D6 (maximum)	D7	D8	L1 ^{+0.3 0}	L2 ^{+0.1 0}	L3 ^{+0.2 0}	L4 (finish range)	L5	L6 ^{+0.2 0}	L7 ^{+0.1}	L8 (maximum)	L9 (maximum)
6	20.5	M20x1	19	16.5	11	6	3	25	36	32	30	24	14	4.8	26	47	79
10	24.5	M24x1	23	16.5	11	10.5	3	25	40	36	34	24	15	5.2	29.7	43	79

Pilot operated unloading relief valve (1)

PU/PUE

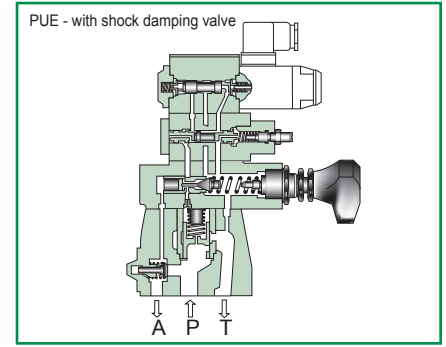
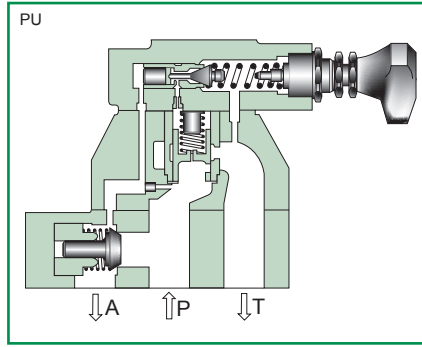
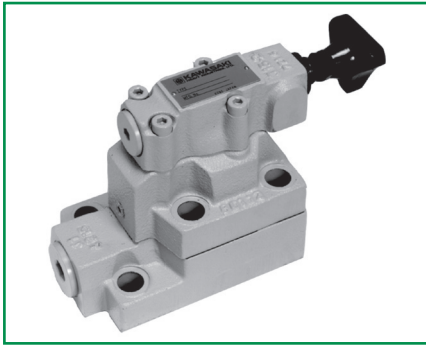

Pilot operated unloading relief valve (1)

Overview

The pilot operated unloading relief valve is used with either an accumulator or a two pump high-low circuit. One state being high flow low pressure and the other low flow high pressure.

In the case of the accumulator circuit, when the pump discharge pressure reaches the cut-out pressure, the valve opens and the pump is unloaded. When the pressure on the accumulator side reaches the cut-in pressure, the valve is closed and the pump is loaded, pumping out the discharged oil to the accumulator side. In the case of the

high-low circuit that uses two pumps, when pressure reaches the set pressure (cut-out pressure), the valve opens, pressure oil from the pumps is automatically returned to the tank and the pump is unloaded. When the pressure falls below the set pressure, the valve is closed and the pumps become automatically loaded.

Features

1. The main valve part is of special shape and a shock when unloaded is very small.
2. An pilot operated unloading relief valve with a solenoid operated directional valve that can be unloaded and loaded with electrical signals is also available.

Type indication

●PU

PU 10 P - 10 - 1 / 315 C -

Pilot operated unloading relief valve

Nominal dimension

10, 20, 30

Connection method

P = Gasket connection type

Series number: 10

Shape of pressure adjusting part

- 1 = Handle adjustment
- 2 = Thread adjustment (with cap)
- 3 = Handle with key adjustment

Type of hydraulic oil

- No symbol = Mineral based hydraulic oil
- V = Phosphate ester based hydraulic oil
- W = Fatty ester based hydraulic oil
- = Water-glycol based hydraulic oil

Check valve provided or not

C = With check valve

Pressure adjustment range

- 80 = 2.0 to 7.9MPa (20 to 80kgf/cm²)
- 160 = 7.9 to 15.7MPa (80 to 160kgf/cm²)
- 315 = 15.7 to 30.9MPa (160 to 315kgf/cm²)

●Hydraulic symbols

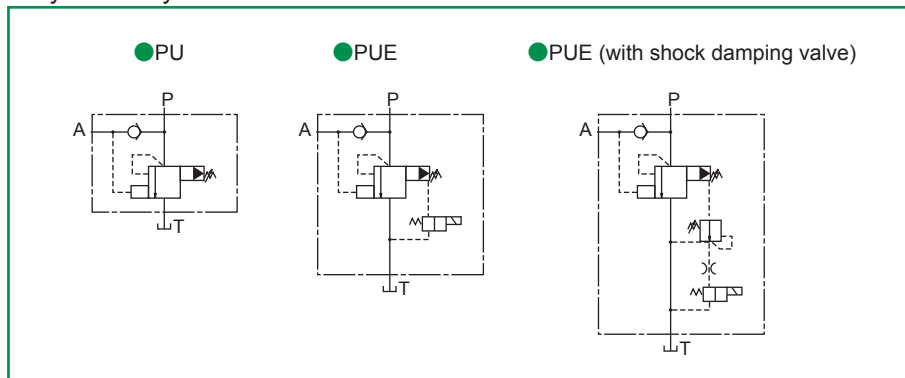

●Pressure increase value per turn (clockwise) of adjust thread MPa (kgf/cm²)

Highest adjustment pressure	Nominal dimension	10, 20, 30
80		1.96 (20.0)
100		3.53 (36.0)
315		7.35 (75.0)

(Note) As the above value is a calculated value, there are slight variations in the product.

● PUE

PUE 10 P - 10 - B 1 / 80 C - WD 24 CL - S -

Pilot operated unloading relief valve (with solenoid valve)

Nominal dimension
10, 20, 30

Connection method
P = Gasket connection type

Series number: 10

Spool type of solenoid operated directional valve

A = Normal close

B = Normal open

Shape of pressure adjusting part
1 = Handle adjustment
2 = Thread adjustment (with cap)
3 = Handle with key adjustment

Pressure adjustment range
80 = 2.0 to 7.9MPa (20 to 80kgf/cm²)
160 = 7.9 to 15.7MPa (80 to 160kgf/cm²)
315 = 15.7 to 30.9MPa (160 to 315kgf/cm²)

Check valve provided or not
C = With check valve

Type of hydraulic oil
No symbol = Mineral based hydraulic oil
V = Phosphate ester based hydraulic oil
W = Fatty ester based hydraulic oil
W1 = Water-glycol based hydraulic oil

Shock damping valve provided or not
No symbol = Without shock damping valve
S = With shock damping valve

Electric connection symbol

Symbol	Explanation	Input power supply		
		A	D	R
B	With DIN connector	○	○	—
C	With DIN large connector	○	○	○
CL	With DIN large connector with lamp	○	○	—

Input voltage
12 = 12V
24 = 24V
100 = 100V
200 = 200V

Input power supply
A = Alternating current
D = Direct current
R = AC/DC conversion

Solenoid type
W = Wet type
(with standard emergency manual operation)

■ Specifications

Nominal dimension		10	20	30
Maximum working pressure MPa (kgf/cm ²)	Port A, P	30.9 (315) (Note 3)		
	Port T	PU	30.9 (315)	
PUE		15.7 (160)		
Maximum flow rate	L/min	50	100	250
Type of solenoid operated directional valve (Note 1)		Equivalent to DE5P-10-2 ⁰¹ / ₀₂		
Type of shock damping valve (Note 2)		ZNS5-1		
Mass	kg	3.8	7.7	13.4

(Note 1) Refer to the section of the solenoid operated directional valve "DE5".

(Note 2) Refer to "ZNS5" for the specifications.

(Note 3) Pressure adjustment range: When 80 is adjusted to 6.4 to 7.9 MPa (65 to 80 kgf/cm²), the maximum working pressure of A port is up to 9.8 MPa (100 kgf/cm²)

Pressure adjustment range: When 160 is adjusted to 12.8 to 15.7 MPa (130 to 160 kgf/cm²), the maximum working pressure of A port is 15.7 MPa (160 kgf/cm²).

■ Sub-plate

Valve type	Sub-plate type	Connection diameter	Mass
PU(E)10	P-PU10R38-0	Rc 3/8	2.1kg
	P-PU10G38-0	G 3/8	
	P-PU10R12-0	Rc 1/2	
	P-PU10G12-0	G 1/2	
PU(E)20	P-PU20R34-0	Rc 3/4	4.4kg
	P-PU20G34-0	G 3/4	
	P-PU20R1-0	Rc1	
	P-PU20G1-0	G1	
PU(E)30	P-PU30R54-0	Rc1 1/2	6.9kg
	P-PU30G54-0	G1 1/2	
	P-PU30R32-0	Rc1 1/2	
	P-PU30G32-0	G1 1/2	

When you use a sub-plate, please place an order for the above sub-plate type.
For the dimension drawing, refer to page 12, 13 of the appendix.

■ Precautions in use

- If piping from A port to the accumulator (ACC) is thin and long, the difference between the cut-out pressure and cut-in pressure becomes small, causing the operation to be unstable. Install piping so that the pressure drop amount (ΔP) from A port to ACC is [(cut-out pressure – cut-in pressure) x 1/3].

■ Accessories

● Mounting bolt

Type	Hexagon socket head cap thread	Quantity	Tightening torque N·m (kgf·cm)
PU(E)10	M10×40L	4 pcs.	56.8 ± 8.5 (580 ± 87)
	M16×50L	2 pcs.	
PU(E)20	M16×95L	4 pcs.	235.2 ± 35.2 (2400 ± 360)
	M18×70L	2 pcs.	
PU(E)30	M18×120L	4 pcs.	333.2 ± 50.0 (3400 ± 510)

Difference between cut-in pressure and cut-out pressure (viscosity 36 mm²/s(cSt))

● Pressure adjustment range : 80

● Pressure adjustment range : 160

● Pressure adjustment range : 315

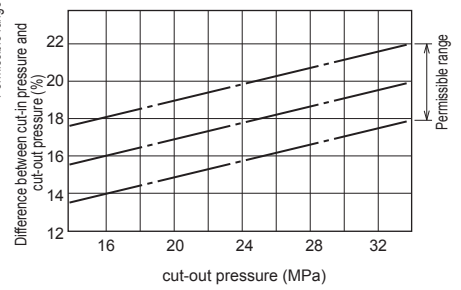
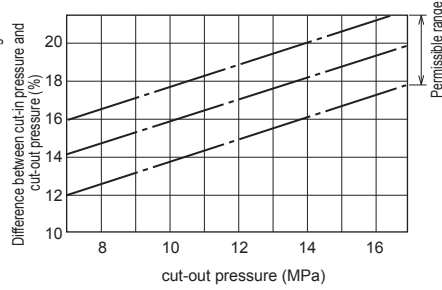
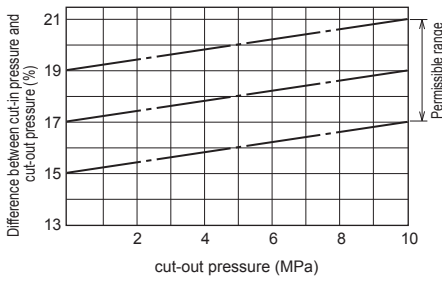

Pressure drop characteristics (viscosity 36 mm²/s(cSt))

● PU/PUE10

● PU/PUE20

● PU/PUE30

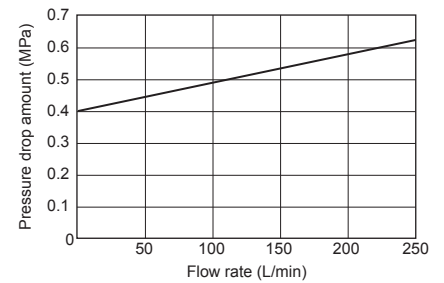
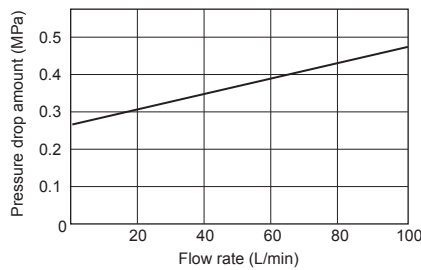
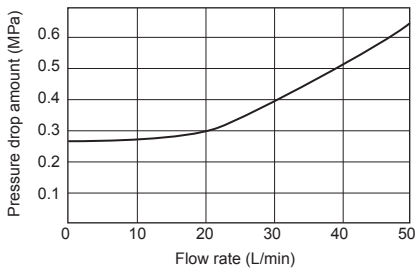

Dimension drawing

● PU10

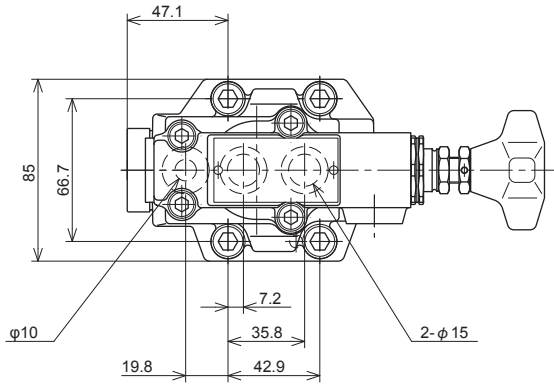

● Handle adjusting type

● Screw adjusting type

● Handle with key adjusting type

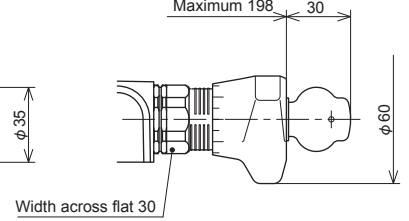
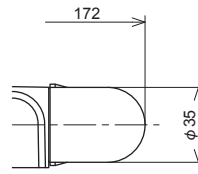
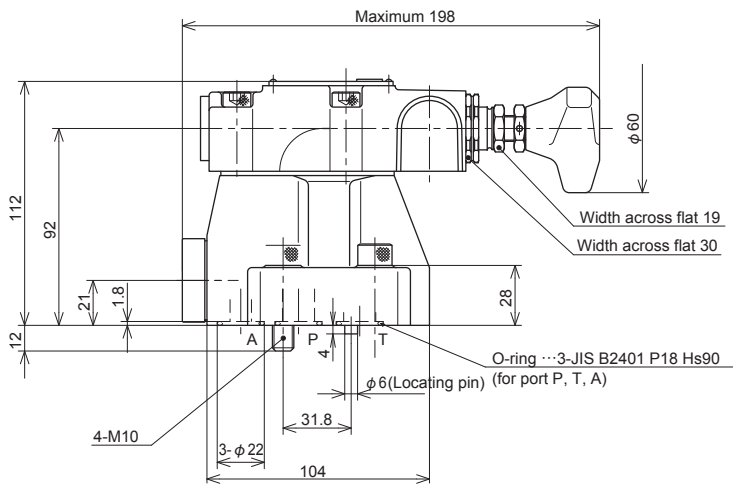

● PU₂₀ 30

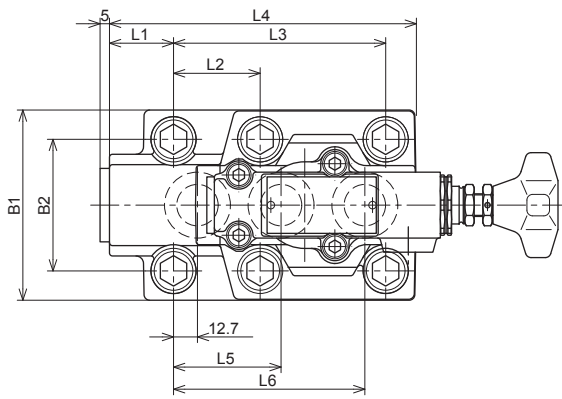

● Handle adjusting type

● Screw adjusting type

● Handle with key adjusting type

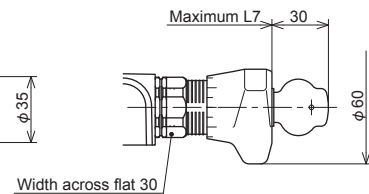
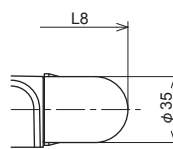
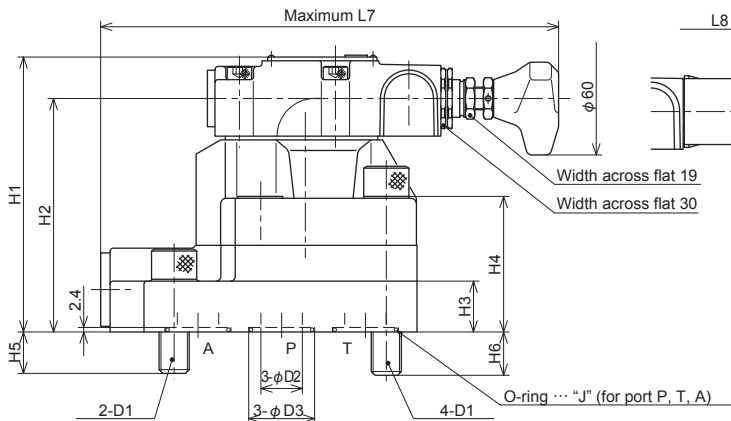

Nominal dimension	B1	B2	L1	L2	L3	L4	L5	L6	L7	L8	D1	D2	D3	H1	H2	H3	H4	H5	H6	O-ring dimension "J"
20	101	69.9	30	46	112.7	159	57.1	101.6	247	215	M16	25	35	144	124	28	72	22	23	JIS B2401G30 Hs90
30	116	82.5	51.5	50.8	139.7	208.5	63.5	127	270.5	243	M18	31	40	165	145	45	93	25	27	JIS B2401G35 Hs90

PUE10

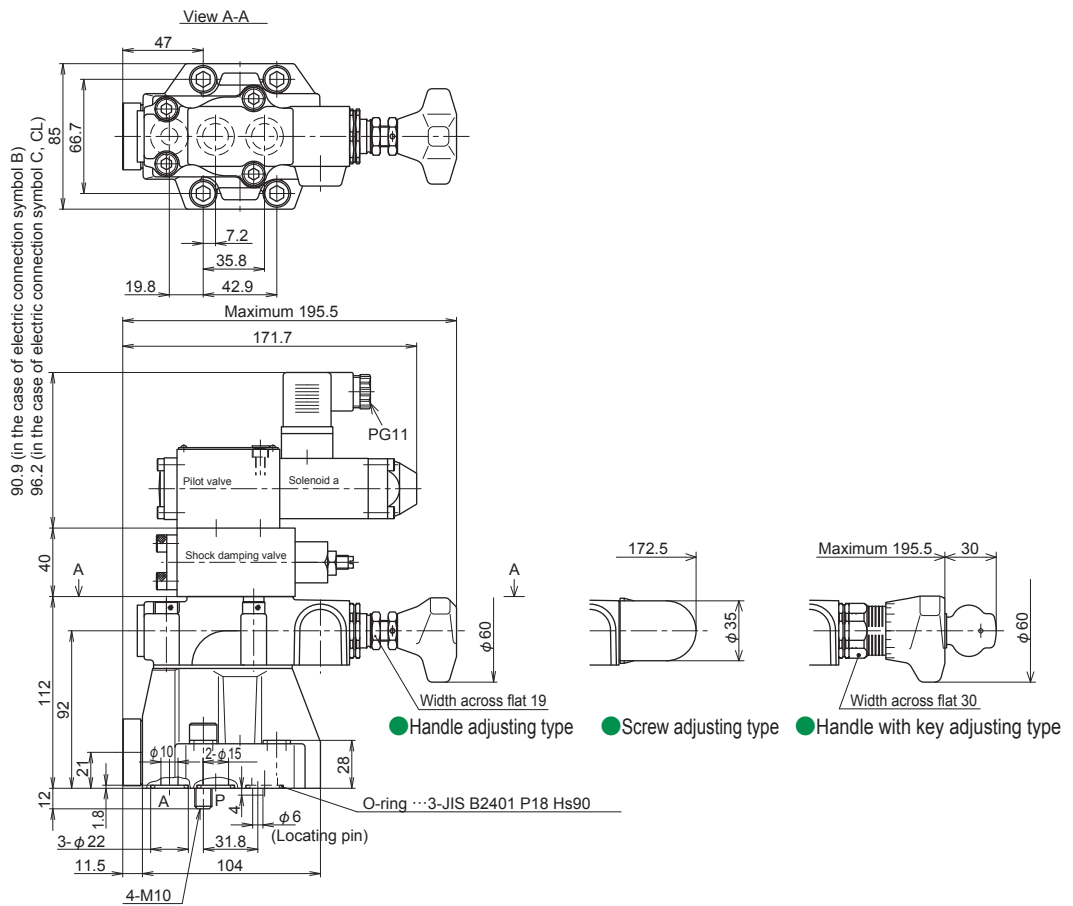

PUE²⁰₃₀

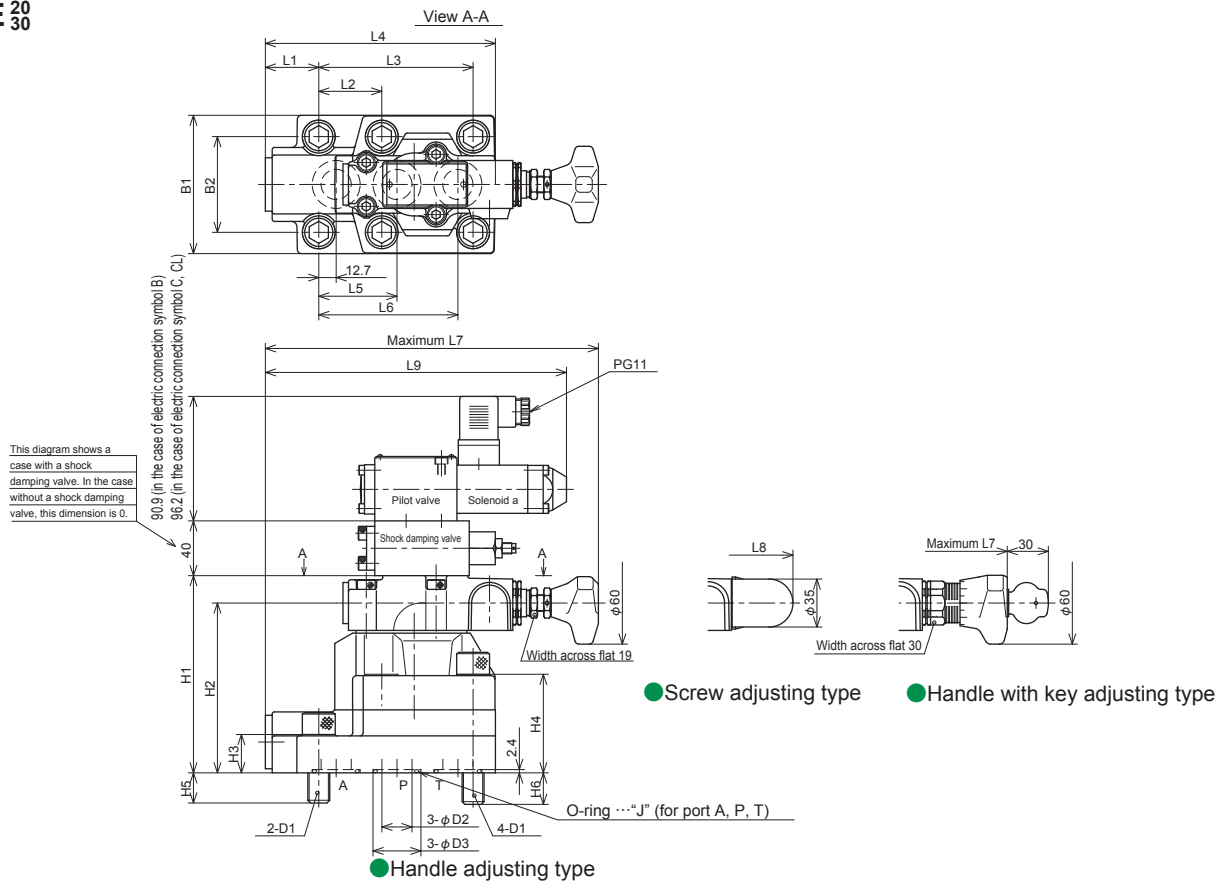

Nominal dimension	B1	B2	L1	L2	L3	L4	L5	L6	L7	L8	L9	D1	D2	D3	H1	H2	H3	H4	H5	H6	O-ring dimension "J"
20	101	69.9	39	46	112.7	168	57.1	101.6	243.2	220.7	219.9	M16	22	35	144	124	28	72	22	23	3-JIS B2401G30 Hs90
30	116	82.5	60.3	50.8	139.7	217.5	63.5	127	272	249.5	248.7	M18	28	40	165	145	45	93	25	27	3-JIS B2401G35 Hs90

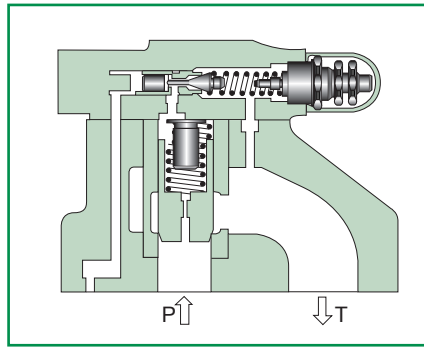
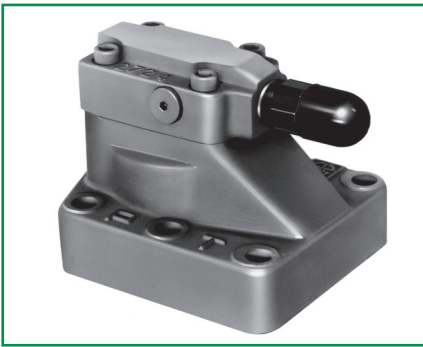

Overview

The pilot operated unloading relief valve is used with either an accumulator or a two pump high-low circuit. One state being high flow low pressure and the other low flow high pressure. In the case of the accumulator circuit, when the pump discharge pressure reaches the cut-out pressure, the valve opens and the pump is unloaded. When the pressure on the accumulator side reaches the cut-in pressure, the valve is closed and the pump is loaded, pumping out the discharged oil to the

accumulator side. In the case of the high-low circuit that uses two pumps, when pressure reaches the set pressure (cut-out pressure), the valve opens, pressure oil from the pumps is automatically returned to the tank and the pump is unloaded. When the pressure falls below the set pressure, the valve is closed and the pumps become automatically loaded.

Type indication

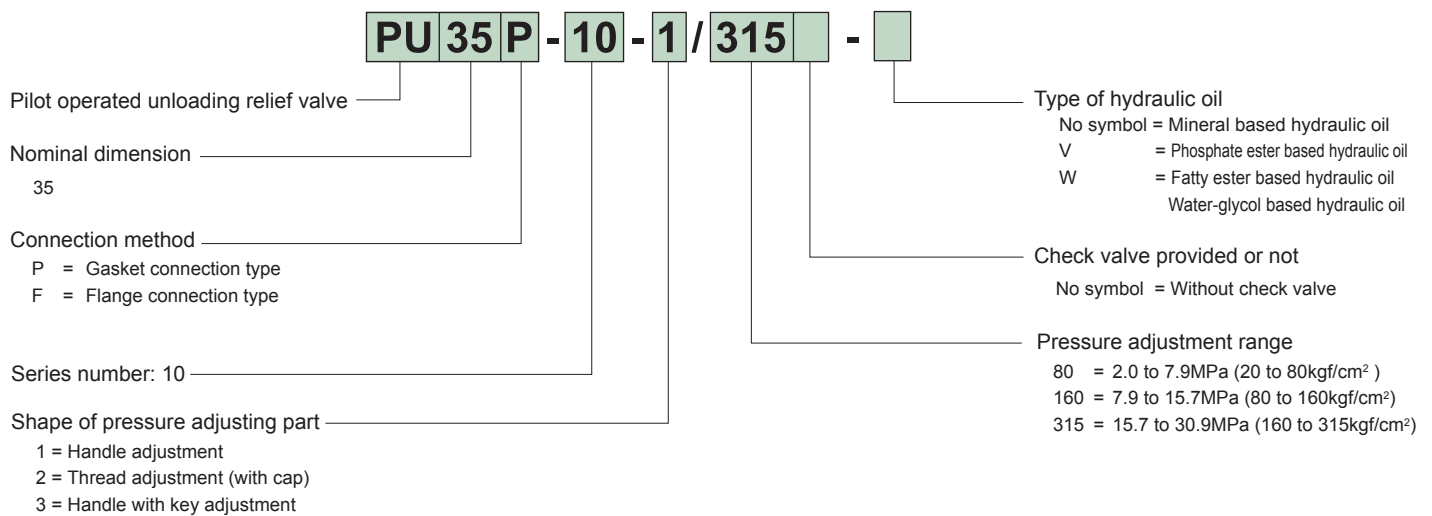

Hydraulic symbols

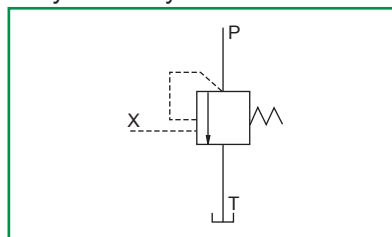

Pressure increase value per turn (clockwise) of adjust thread MPa (kgf/cm²)

Highest adjustment pressure	Nominal dimension	35
80	1.96 (20.0)	
160	3.53 (36.0)	
315	7.35 (75.0)	

(Note) As the above value is a calculated value, there are slight variations in the product.

Flange

Valve type	Maximum working pressure	Flange type	Connection diameter	Mass
PU35F	20.6MPa	TFAA-40	2B	2.6kg
	30.9MPa	TFXA-40	2B	2.7kg

When you use a flange, please place an order for the above flange type. For the dimension drawing, refer to page 16 of the appendix.

Accessories

Mounting bolt

Type	Hexagon socket head cap thread	Quantity	Tightening torque N·m (kgf·cm)
PU35P	M16×70L	6 pcs.	235.2±35.2 (2400±360)

Pressure drop characteristics (viscosity 36 mm²/s (cSt))

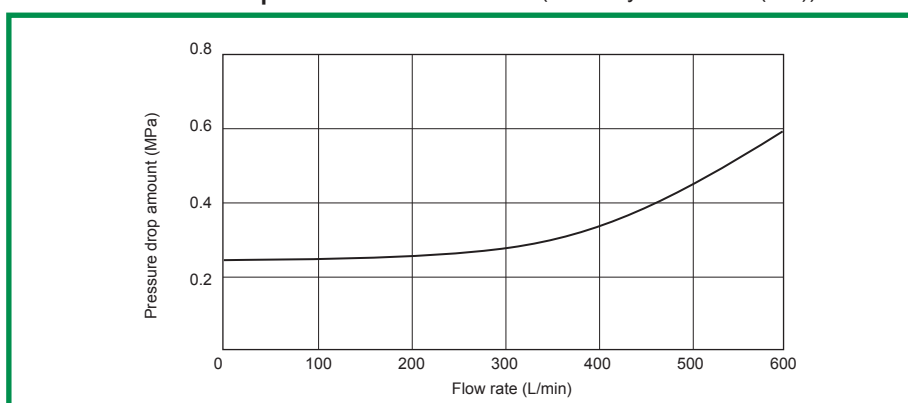

Specifications

Nominal dimension		35
Maximum working pressure MPa (kgf/cm ²)		30.9 (315)
Maximum flow rate L/min		600
Pressure ratio between cut-in and cut-out (%)		82 (Note)
Mass kg	Gasket connection type	17
	Flange connection type	

(Note) Although the design value is 82%, the pressure ratio may change to approximately 78 – 86% depending on the set pressure or flow rate.

Precautions in use

- If piping from the check valve to the accumulator (ACC) is thin and long, the difference between the cut-out pressure and cut-in pressure becomes small, causing the operation to be unstable. Install piping so that the pressure drop amount (ΔP) from the check valve to ACC is [(cut-out pressure – cut-in pressure) x 1/3].

Dimension drawing

●PU35P (Gasket connection type)

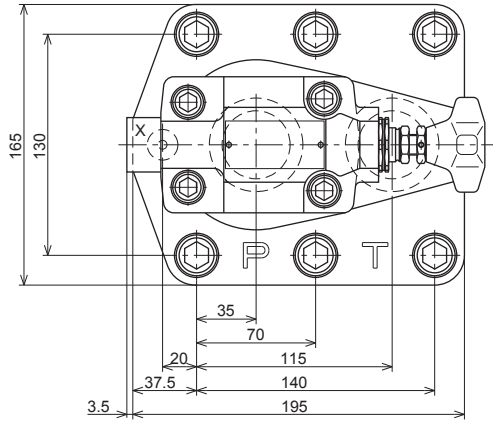

● Handle adjusting type ● Screw adjusting type ● Handle with key adjusting type

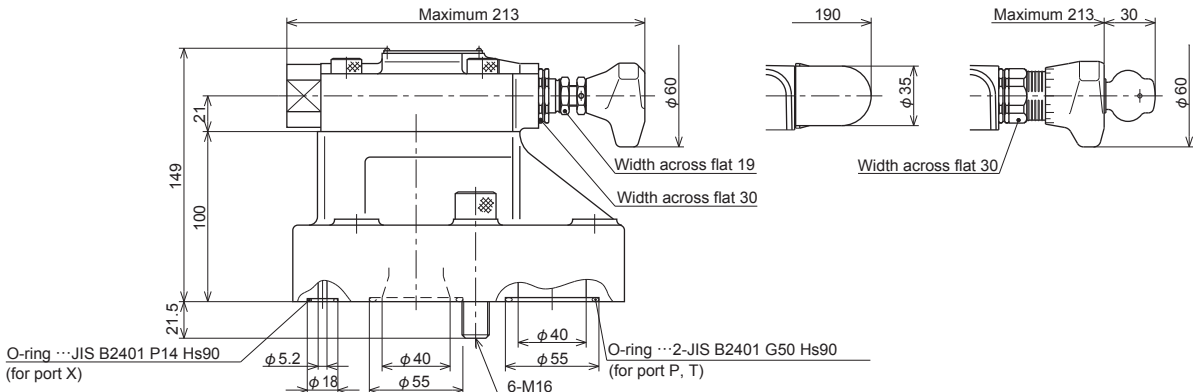

●PU35F (Flange connection type)

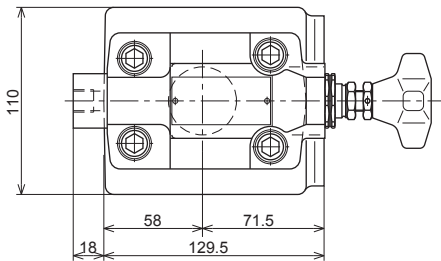

● Handle adjusting type ● Screw adjusting type ● Handle with key adjusting type

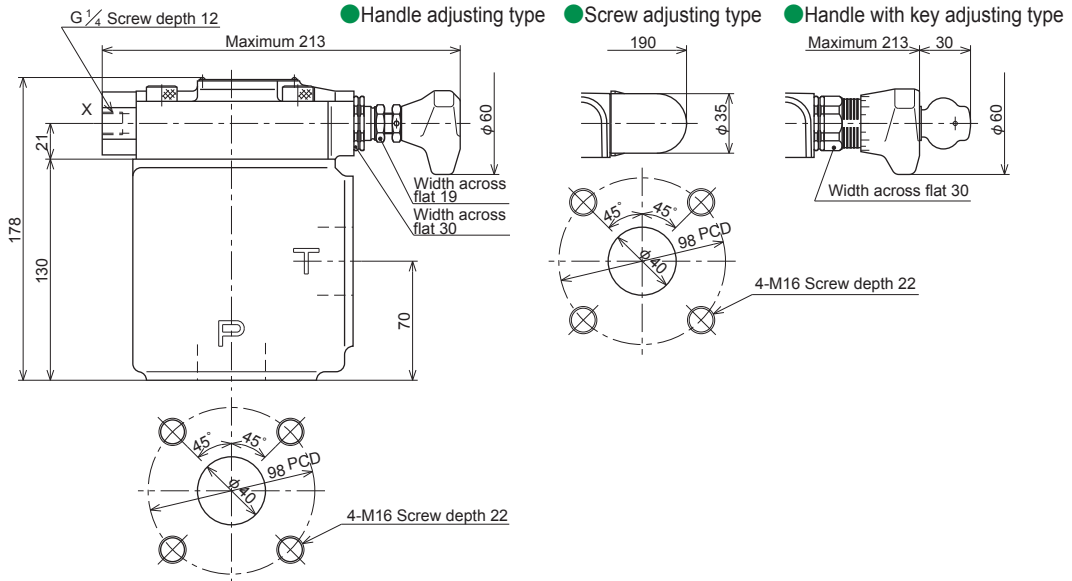

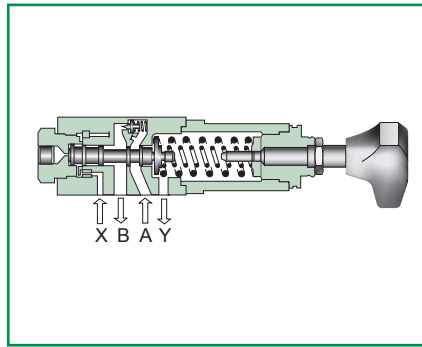
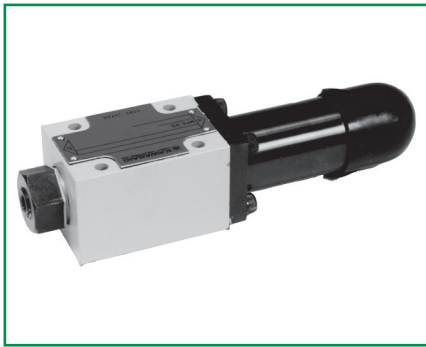

Sequence valve – Direct operated type

Overview

This direct operated type sequence valve is used when sequence action or unloading action of the hydraulic circuit is performed.

Features

- As this is a direct operated type sequence valve, the structure is simple and compact.
- The interface dimension of the valve is identical with that of the solenoid operated directional valve. (6 size)
- It performs various functions by the connection method with the pilot and drain.

Type indication

SD 6 P - 10 - 1 / 210 Y C -

Sequence valve – Direct Operated type

Nominal dimension

6, 10

Connection method

P = Gasket connection type

Series number: 10

Shape of pressure adjusting part

- 1 = Handle adjustment
- 2 = Thread adjustment (with cap)
- 3 = Handle with key adjustment

Type of hydraulic oil

- No symbol = Mineral based hydraulic oil
- V = Phosphate ester based hydraulic oil
- W = Fatty ester based hydraulic oil
- Water-glycol based hydraulic oil

Check valve provided or not

- No symbol = Without check valve
- C = With check valve

Pilot, Drain system

	Internal pilot	External pilot
Internal drain	No symbol	X
External drain	Y	XY

Pressure adjustment range MPa (kgf/cm²)

Symbol	Nominal dimension	
	6	10
25	0 to 2.5 (0 to 25)	0.2 to 2.5 (2 to 25)
75	0 to 7.4 (0 to 75)	0.4 to 7.4 (4 to 75)
150	2.9 to 14.7 (30 to 150)	1.0 to 14.7 (10 to 150)
210	3.4 to 20.6 (35 to 210)	1.0 to 20.6 (10 to 210)

Hydraulic symbols

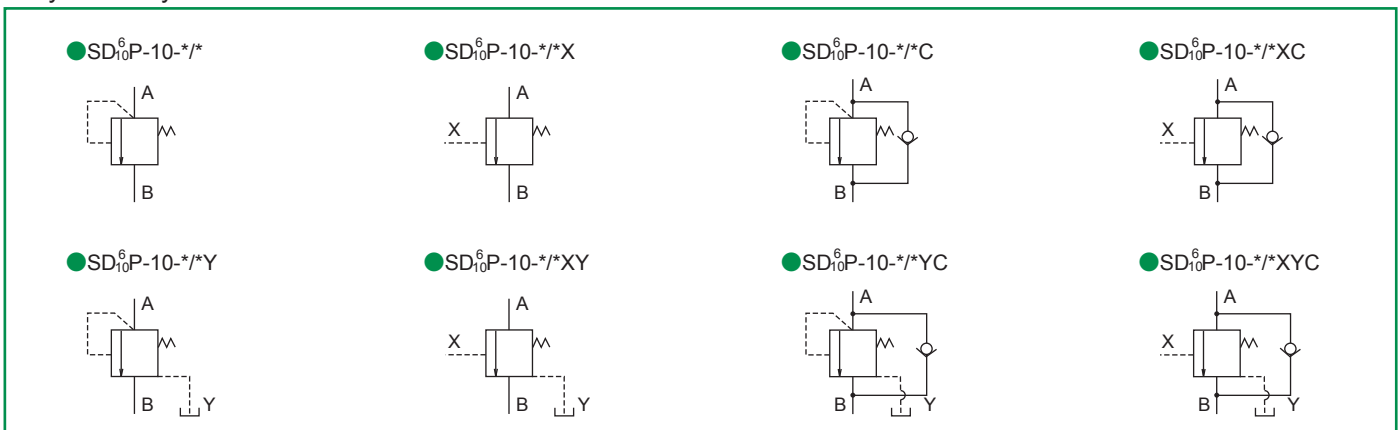

Specifications

Nominal dimension		6	10
Maximum working pressure MPa (kgf/cm ²)	Port A, X	20.6 (210) (Note)	
	Port B	20.6 (210)	
	Port Y	5.9 (60)	1.5 (15)
Maximum flow rate	L/min	30	50
Mass	kg	1.2	3.2

(Note) When the maximum adjustment pressure of 150 is adjusted to 12.3 to 14.7 MPa (125 to 150 kgf/cm²), the maximum working pressure becomes 16.7 MPa (170 kgf/cm²)

- Pressure increase value per turn (clockwise) of adjust thread MPa (kgf/cm²)

Highest adjustment pressure	Nominal dimension	6	10
25		0.30 (3.1)	0.29 (3.0)
75		0.87 (8.9)	0.86 (8.8)
150		1.51 (15.4)	1.73 (17.6)
210		2.05 (20.9)	2.40 (24.5)

(Note) As the above value is a calculated value, there are slight variations in the product.

Sub-plate

Valve type	Sub-plate type	Connection diameter	Mass
SD6P	P-DE6R14-0	Rc 1/4	1.0kg
	P-DE6G14-0	G 1/4	
	P-DE6R38-0	Rc 3/8	1.3kg
	P-DE6G38-0	G 3/8	
SD10P	P-CHY10R14-0	Rc 1/4	2.1kg
	P-CHY10G14-0	G 1/4	
	P-CHY10R38-0	Rc 3/8	
	P-CHY10G38-0	G 3/8	
	P-CHY10R12-0	Rc 1/2	
	P-CHY10G12-0	G 1/2	

When you use a sub-plate, please place an order for the above sub-plate type. For the dimension drawing, refer to page 6, 11 of the appendix.

Accessories

- Mounting bolt

Type	Hexagon socket head cap thread	Quantity	Tightening torque N·m (kgf·cm)
SD6P	M5×50L	4 pcs.	6.9±1.0 (70±10)
SD10P	M10×70L	4 pcs.	56.8±8.5 (580±87)

Pressure override characteristics (viscosity 36 mm²/s (cSt))

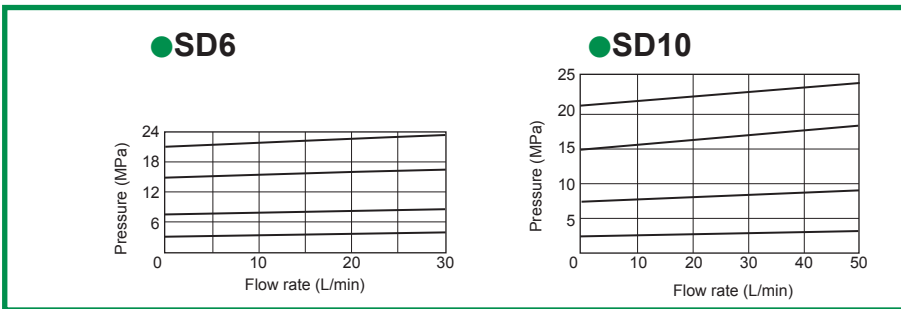

Minimum adjustment pressure characteristics (viscosity 36 mm²/s (cSt))

- In the case of adjustment part fully open (Pressure adjustment range: 25)

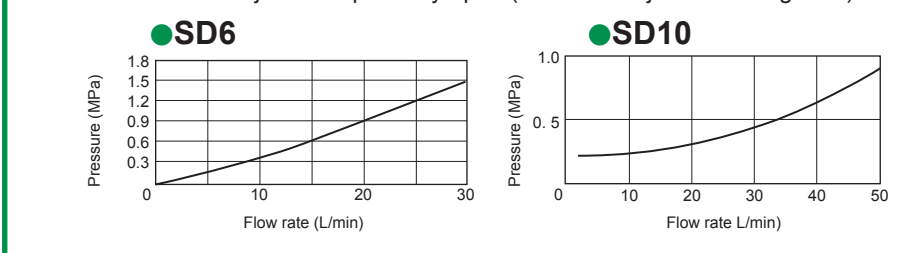

Pressure drop characteristics (viscosity 36 mm²/s (cSt))

- In the case of check valve free flow

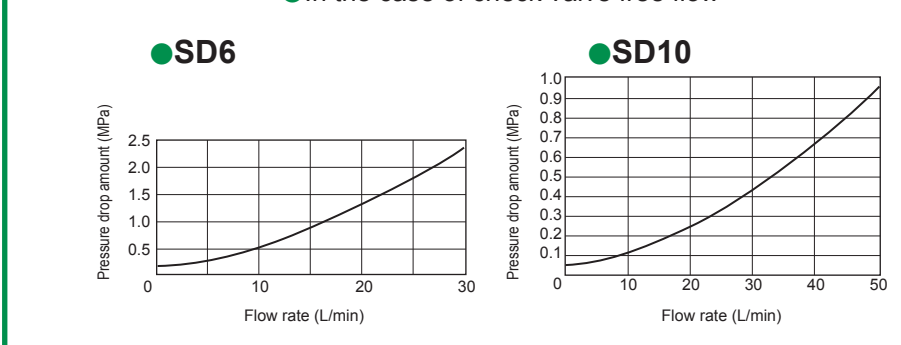

Dimension drawing

●SD6

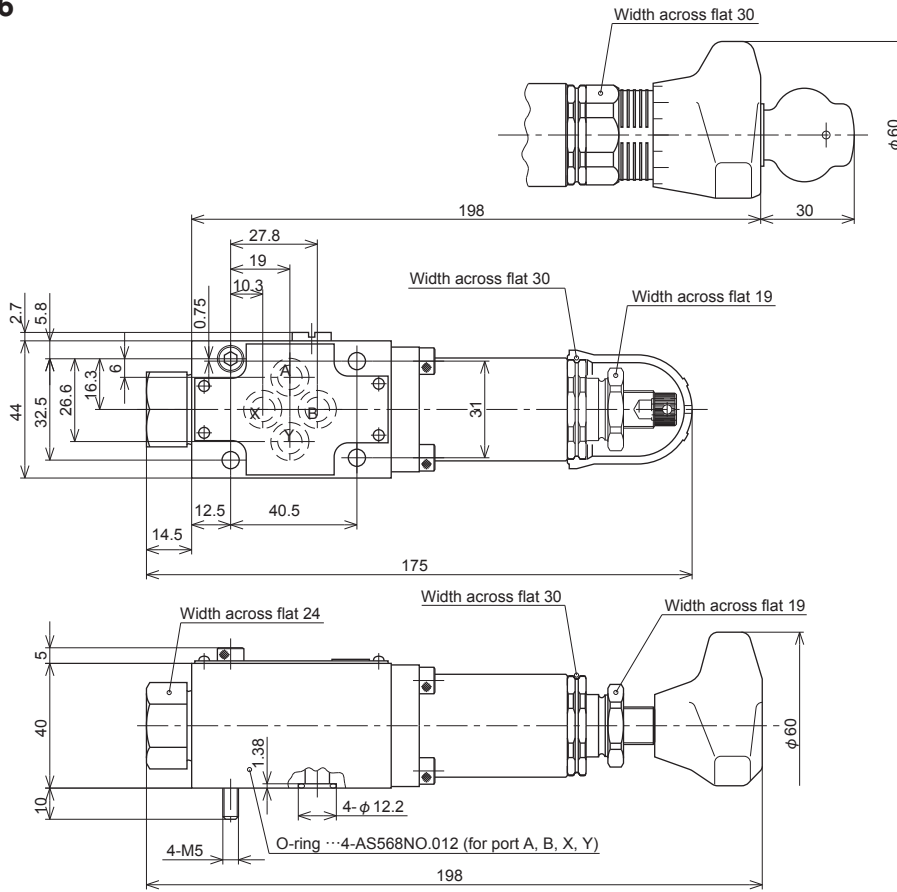

● Handle with key adjusting type

● Screw adjusting type

● Handle adjusting type

●SD10

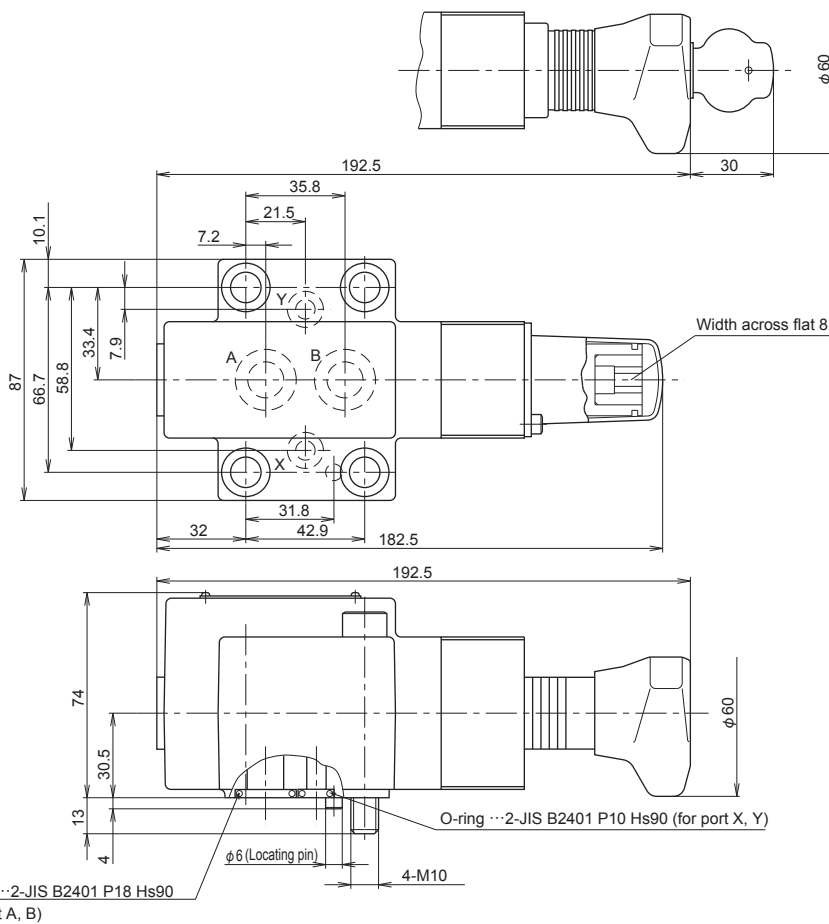

● Handle with key adjusting type

● Screw adjusting type

● Handle adjusting type

Sequence valve – Direct operated type

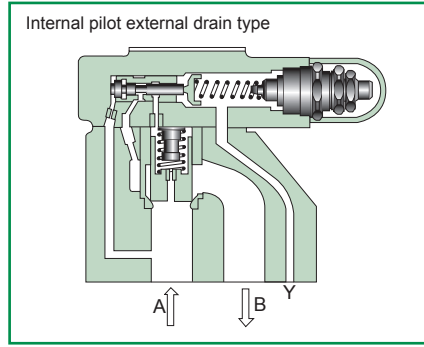
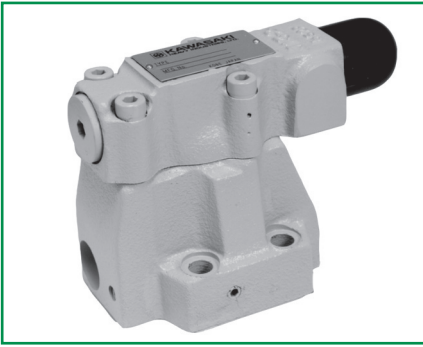

Overview

This balanced piston type pilot operated sequence valve, which is of seat type and controls pressure, is used when sequence action or unloading action of the hydraulic circuit is performed.

Features

1. Compared to the hydrocushion type, the balanced piston type pilot operated is quite superior in override characteristics.
2. As this is of balanced piston type pilot operated, the pressure range can be adjusted in a wide range.
3. It performs various functions by the connection method with the pilot and drain.

Type indication

SB

SB 10P - 10 - 1 / 210XYC -

Sequence valve - Balanced piston type pilot operated

Nominal dimension
10, 20, 30

Connection method
P = Gasket connection type

Series number: 10

Shape of pressure adjusting part
1 = Handle adjustment
2 = Thread adjustment (with cap)
3 = Handle with key adjustment

Highest adjustment pressure
210 = 20.6MPa (210kgf/cm²)

Type of hydraulic oil

- No symbol = Mineral based hydraulic oil
- V = Phosphate ester based hydraulic oil
- W = Fatty ester based hydraulic oil
- Water-glycol based hydraulic oil

Check valve provided or not

- No symbol = Without check valve
- C = With check valve

Pilot, Drain system

	Internal pilot	External pilot
Internal drain	No symbol	X
External drain	Y	XY

Hydraulic symbols

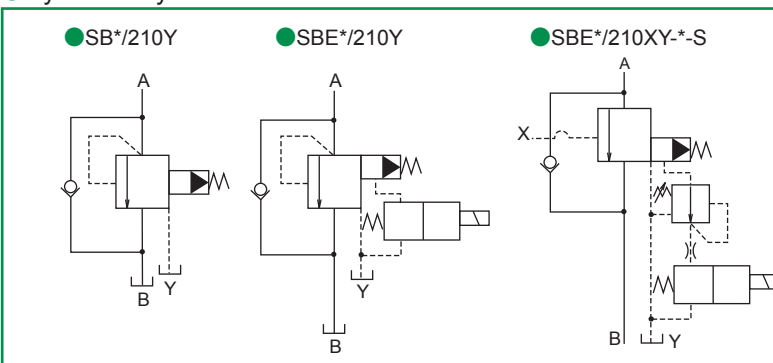

● SBE

SBE10P-10-B1/210XYC-WD24CL-S-

Sequence valve
— Balanced piston type pilot operated (solenoid directional valve)

Nominal dimension
10, 20, 30

Connection method
P = Gasket connection type

Series number

Vent circuit

A = Normal close



B = Normal open



Shape of pressure adjusting part

- 1 = Handle adjustment
- 2 = Thread adjustment (with cap)
- 3 = Handle with key adjustment

Highest adjustment pressure
210 = 20.6MPa (210 kgf/cm²)

Pilot, Drain system

- Y = Internal pilot, external drain
- XY = External pilot, external drain

Check valve provided or not

- No symbol = Without check valve
- C = With check valve

Type of hydraulic oil
No symbol = Mineral based hydraulic oil
V = Phosphate ester based hydraulic oil
W = Fatty ester based hydraulic oil
W1 = Water-glycol based hydraulic oil

Shock damping valve provided or not
No symbol = Without shock damping valve
S = With shock damping valve

Electric connection symbol

Symbol	Explanation	Input power supply		
		A	D	R
B	With DIN connector	○	○	—
C	With DIN large connector	○	○	○
CL	With DIN large connector with lamp	○	○	—

Input voltage

- 12 = 12V
- 24 = 24V
- 100 = 100V
- 200 = 200V

*For details of voltage specifications, refer to "Solenoid specifications" of the solenoid operated directional valve "DE5".

*For other power supply, please contact us.

Input power supply

- A = Alternating current
- D = Direct current
- R = AC/DC conversion

Solenoid type

- W = Wet type (with standard emergency manual operation)

Sequence valve – Balanced piston type pilot operated

■ Specification

Nominal dimension		10	20	30
Maximum working pressure MPa (kgf/cm ²)	Port A, B, X	30.9 (315) (Note 4)		
	Port Y	SB	30.9 (315)	
SBE		15.7 (160)		
Maximum flow rate L/min		150	300	450
Highest adjustment pressure MPa (kgf/cm ²)		20.6 (210) (Note 1)		
Type of solenoid operated directional valve (Note 2)		Equivalent to DE5P-10-2 ⁰¹ ₀₂		
Type of shock damping valve (Note 3)		ZNS5-1		
Mass kg	SB	3.6	5.5	8.2
	SBE	4.7	6.6	9.3

(Note 1) If you wish the maximum adjustment pressure of 30.9 MPa (315 kgf/cm²), please contact us.

(Note 2) Refer to the section of the type number index "DE5".

(Note 3) Refer to the section of the type number index "ZNS5" for the specifications.

(Note 4) When the adjustment pressure is set to 17.2 Mpa (175 kgf/cm²) or less, the maximum working pressure is 19.6 + 0.66 x (set pressure) Mpa (200 + 0.66 x (set pressure) kgf/cm²).

■ Pressure override characteristics (viscosity 36 mm²/s (cSt))

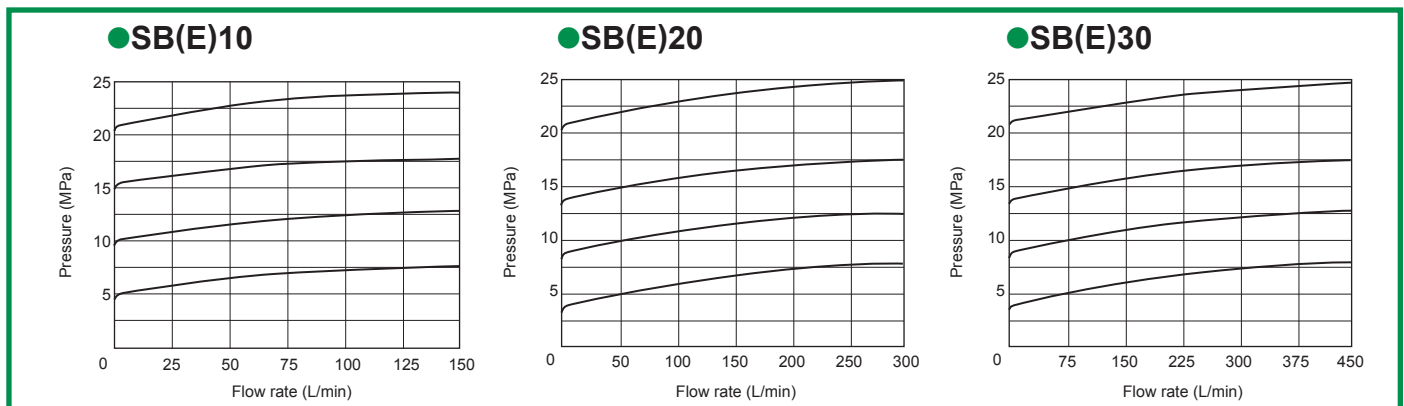

Minimum adjustment pressure characteristics (viscosity 36 mm²/s (cSt))

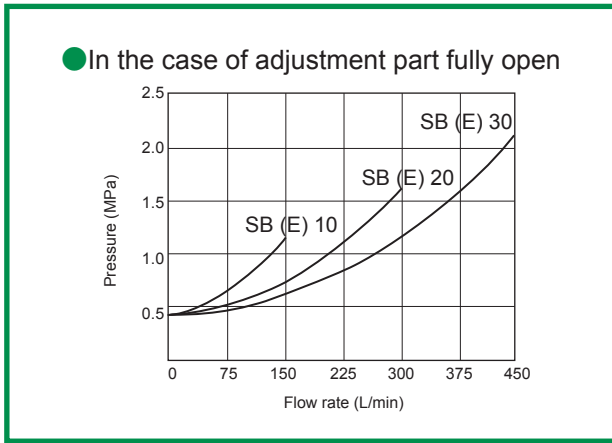

Pressure drop characteristics (viscosity 36 mm²/s (cSt))

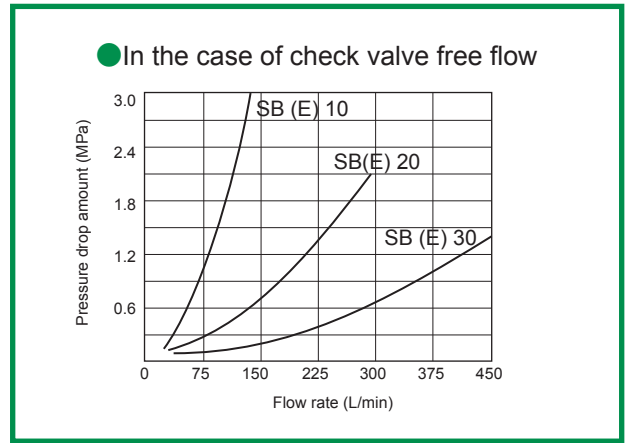

Pilot valve

- The pilot valve used for the sequence valve – balance piston type is as follows. If you need the pilot valve only, please specify “pilot valve type” and contact us.

Nominal dimension	Main valve type	Pilot valve type
SB	Internal pilot, internal drain type	SB10X-10-*/210-*
	Internal pilot, external drain type	
	External pilot, internal drain type	
20	External pilot, external drain type	SB10X-10-*/210XY-*
30		
SBE	Internal pilot, external drain type	SBE10X-10-*/210-*
	20	
	30	SBE10X-10-*/210XY-*

Type indication

● SB10X

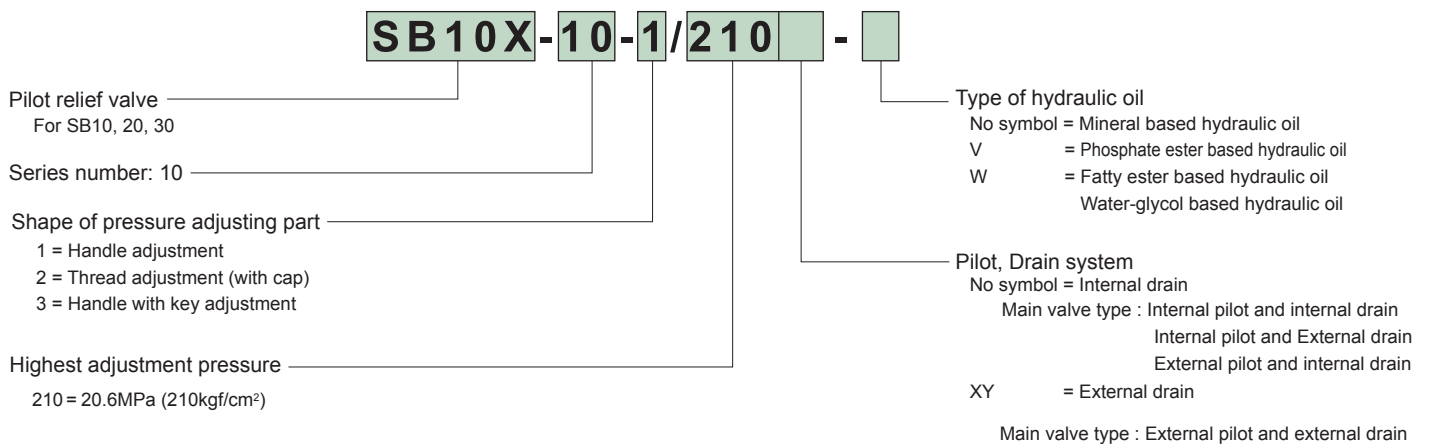

SBE10X

SBE10X-10-B1/210-WD24CL-S-

Pilot relief valve
For SBE10, 20, 30

Series number: 10

Vent circuit

A = Normal close



B = Normal open



Shape of pressure adjusting part

- 1 = Handle adjustment
- 2 = Thread adjustment (with cap)
- 3 = Handle with key adjustment

Highest adjustment pressure

210 = 20.6MPa (210kgf/cm²)

Pilot, Drain system

- No symbol = Internal drain
- Main valve type = Internal pilot and external drain
- External pilot and external drain

- Pressure increase value per turn (clockwise) of adjust thread MPa (kgf/cm²)

Type of hydraulic oil

- No symbol = Mineral based hydraulic oil
- V = Phosphate ester based hydraulic oil
- W = Fatty ester based hydraulic oil
- W1 = Water-glycol based hydraulic oil

Shock damping valve provided or not

- No symbol = Without shock damping valve
- S = With shock damping valve

Electric connection symbol

Symbol	Explanation	Input power supply		
		A	D	R
B	With DIN connector	○	○	—
C	With DIN large connector	○	○	○
CL	With DIN large connector with lamp	○	○	—

Input voltage

- 12 = 12V
- 24 = 24V
- 100 = 100V
- 200 = 200V

Input power supply

- A = Alternating current
- D = Direct current
- R = AC/DC conversion

Solenoid type

- W = Wet type (with standard emergency manual operation)

Highest adjustment pressure	Nominal dimension	10, 20, 30
210		9.77 (99.6)

(Note) As the above value is a calculated value, there are slight variations in the product.

Sub-plate

Valve type	Sub-plate type	Connection diameter	Mass
SB (E) 10	P-CHY10R14-0	Rc 1/4	2.1kg
	P-CHY10G14-0	G 1/4	
	P-CHY10R38-0	Rc 3/8	
	P-CHY10G38-0	G 3/8	
	P-CHY10R12-0	Rc 1/2	
SB (E) 20	P-CHY10G12-0	G 1/2	4.4kg
	P-CHY20R34-0	Rc 3/4	
	P-CHY20G34-0	G 3/4	
	P-CHY20R1-0	Rc1	
SB (E) 30	P-CHY20G1-0	G1	6.9kg
	P-CHY30R54-0	Rc 1 1/4	
	P-CHY30G54-0	G 1 1/4	
	P-CHY30R32-0	Rc 1 1/2	
	P-CHY30G32-0	G 1 1/2	

When you use a sub-plate, please place an order for the above sub-plate type.

For the dimension drawing, refer to page 6, 7 of the appendix.

Accessories

- Mounting bolt

Type	Hexagon socket head cap thread	Quantity	Tightening torque N·m (kgf·cm)
SB (E) 10	M10×40L	4 pcs.	56.8±8.5 (580±87)
SB (E) 20	M10×50L	4 pcs.	
SB (E) 30	M10×60L	6 pcs.	

Dimension drawing

SB

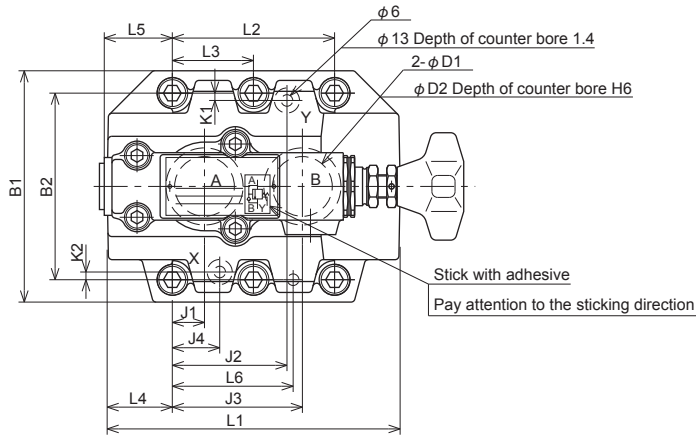

● Handle adjusting type

● Screw adjusting type

● Handle with key adjusting type

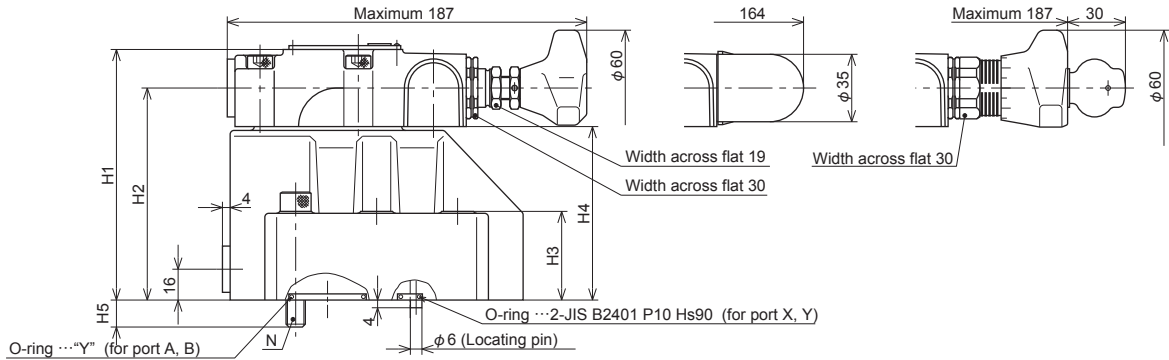

Nominal dimension	B1	B2	N	D1	D2	H1	H2	H3	H4	H5	H6	L1	L2	L3	L4	L5	L6	O-ring dimension "Y"	J1	J2	J3	J4	K1	K2
10	85	66.7	4-M10	15	22	112	92	28	72	12	1.8	104	42.9	—	35.5	38.5	31.8	2-JIS B2401 P18 Hs90	7.2	21.5	35.8	21.5	7.9	7.9
20	102	79.4	4-M10	25	35	122	102	38	82	2.4	121	60.3	—	33.5	41	44.5	2-JIS B2401 G30 Hs90	11.1	39.7	49.2	20.6	6.4	6.4	
30	120	96.8	6-M10	31	40	130	110	46	90	14	152	84.2	42.1	34	35.3	62.7	2-JIS B2401 G35 Hs90	16.7	59.5	67.5	24.6	3.8	4	

SBE

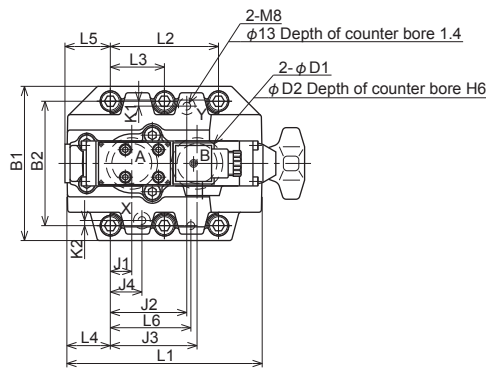

● Handle adjusting type

● Screw adjusting type

● Handle with key adjusting type

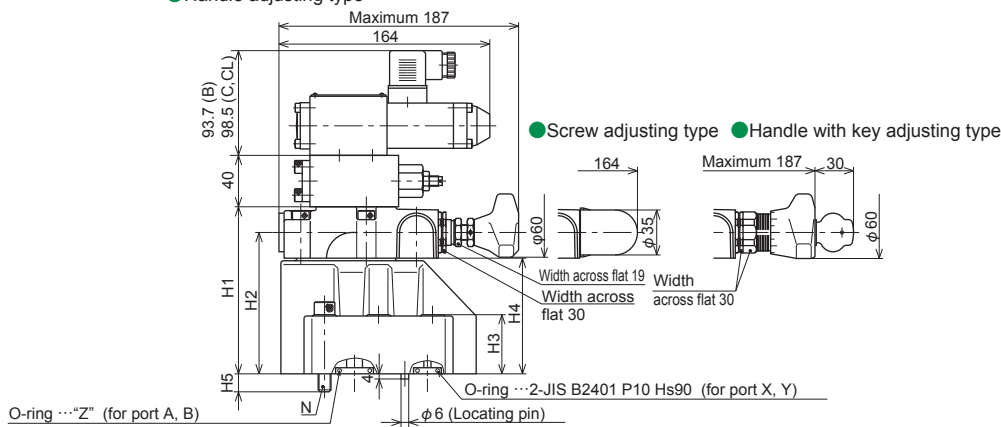

Nominal dimension	B1	B2	N	D1	D2	H1	H2	H3	H4	H5	H6	L1	L2	L3	L4	L5	L6	O-ring dimension "Z"	J1	J2	J3	J4	K1	K2
10	85	66.7	4-M10	15	22	112	92	28	72	12	1.8	104	42.9	—	35.5	38.5	31.8	2-JIS B2401 P18 Hs90	7.2	21.5	35.8	21.5	7.9	7.9
20	102	79.4	4-M10	25	35	122	102	38	82	2.4	121	60.3	—	33.5	41	44.5	2-JIS B2401 G30 Hs90	11.1	39.7	49.2	20.6	6.4	6.4	
30	120	96.8	6-M10	31	40	130	110	46	90	14	152	84.2	42.1	34	35.3	62.7	2-JIS B2401 G35 Hs90	16.7	59.5	67.5	24.6	3.8	4	

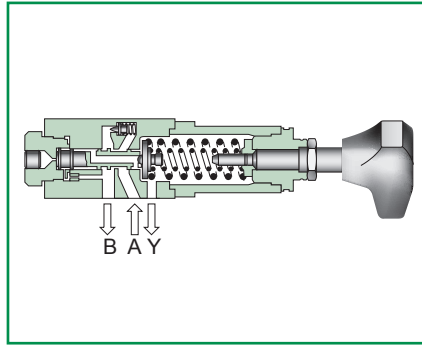
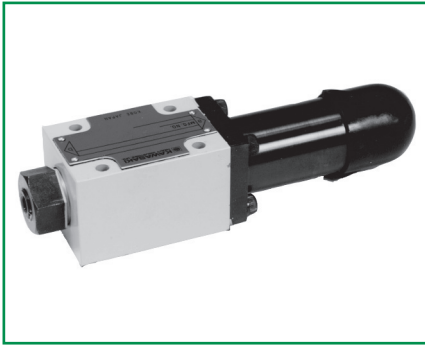

Pressure reducing valve – Direct operated type

Overview

This direct operated type pressure reducing valve is used for reducing the pressure of the hydraulic circuit. Even if the primary side pressure fluctuates, the secondary side pressure can be kept at the specified pressure.

Features

1. As this is a direct operated type pressure reducing valve, the structure is simple and compact.
2. The interface dimension of the valve is identical with that of the solenoid operated directional valve (6 size).
3. Compared to the balanced piston type

4. pilot operated, the drain amount is very small.
4. When the secondary side pressure is going to increase above the specified pressure, oil escapes to the tank side, keeping the secondary side pressure at the specified pressure.

Type indication

PRD 6 P - 10 - 1 / 150 Y C -

- Pressure reducing valve – Direct operated type
- Nominal dimension: 8, 10
- Connection method: P = Gasket connection type
- Series number: 10
- Shape of pressure adjusting part:
 - 1 = Handle adjustment
 - 2 = Thread adjustment (with cap)
 - 3 = Handle with key adjustment
- Type of hydraulic oil:
 - No symbol = Mineral based hydraulic oil
 - V = Phosphate ester based hydraulic oil
 - W = Fatty ester based hydraulic oil
 - Water-glycol based hydraulic oil
- Check valve provided or not:
 - No symbol = Without check valve
 - C = With check valve
- Drain system:
 - Y = External drain
- Pressure adjustment range MPa (kgf/cm²)

Hydraulic symbols

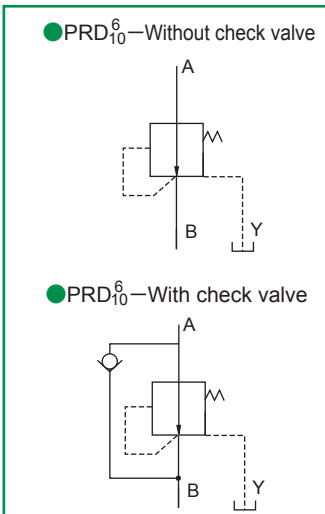

Symbol	Nominal dimension	
	6	10
25	0.5 to 2.5 (5 to 25)	0.5 to 2.5 (5 to 25)
75	2.0 to 7.4 (20 to 75)	1.0 to 7.4 (10 to 75)
150	6.4 to 14.7 (65 to 150)	2.0 to 14.7 (20 to 150)
210	7.9 to 20.6 (80 to 210)	2.0 to 20.6 (20 to 210)

Specifications

Nominal dimension		6	10
Maximum working pressure MPa (kgf/cm ²)	Port A	30.9 (315)	
	Port B	20.6 (210)	
	Port Y	5.9 (60)	1.5 (15)
Maximum flow rate	L/min	30	45
Mass	kg	1.2	3.2

Pressure override characteristics (viscosity 36 mm²/s (cSt))

●PRD6

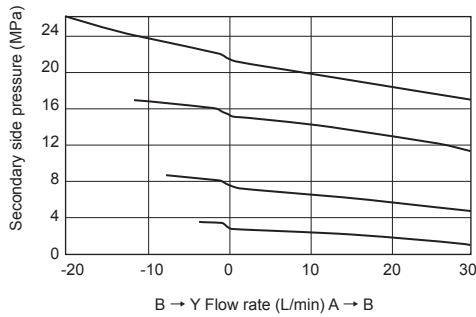

●PRD10

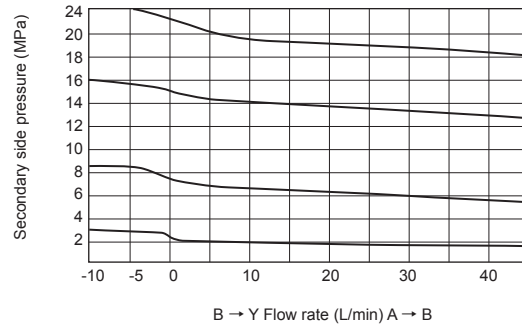

Pressure drop characteristics (viscosity 36 mm²/s (cSt))

In the case of check valve free flow

●PRD6

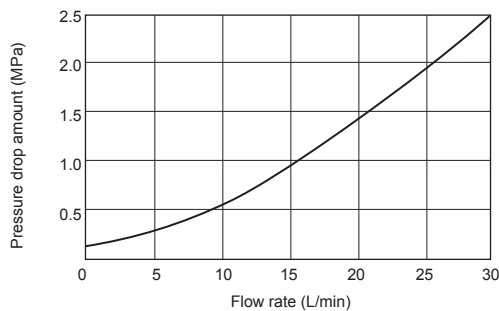

●PRD10

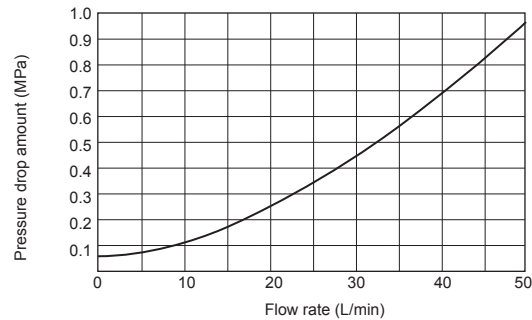

●Pressure increase value per turn (clockwise) of adjust thread MPa (kgf/cm²)

Highest adjustment pressure	Nominal dimension	6	10
25		0.30 (3.1)	0.29 (3.0)
75		0.87 (8.9)	0.86 (8.8)
150		1.51 (15.4)	1.73 (17.6)
210		2.05 (20.9)	2.40 (24.5)

(Note) As the above value is a calculated value, there are slight variations in the product.

Sub-plate

Valve type	Sub-plate type	Connection diameter	Mass
PRD6P	P-DE6R14-0	Rc 1/4	1.0kg
	P-DE6G14-0	G 1/4	
	P-DE6R38-0	Rc 3/8	1.3kg
	P-DE6G38-0	G 3/8	
PRD10P	P-CHY10R14-0	Rc 1/4	2.1kg
	P-CHY10G14-0	G 1/4	
	P-CHY10R38-0	Rc 3/8	
	P-CHY10G38-0	G 3/8	
	P-CHY10R12-0	Rc 1/2	
	P-CHY10G12-0	G 1/2	

When you use a sub-plate, please place an order for the above sub-plate type.
For the dimension drawing, refer to page 6, 11 of the appendix.

Accessories

●Mounting bolt

Type	Hexagon socket head cap thread	Quantity	Tightening torque N·m (kgf·cm)
PRD6	M5×50L	4 pcs.	6.9±1.0 (70±10)
PRD10	M10×70L	4 pcs.	56.8±8.5 (580±87)

Dimension drawing

●PRD6

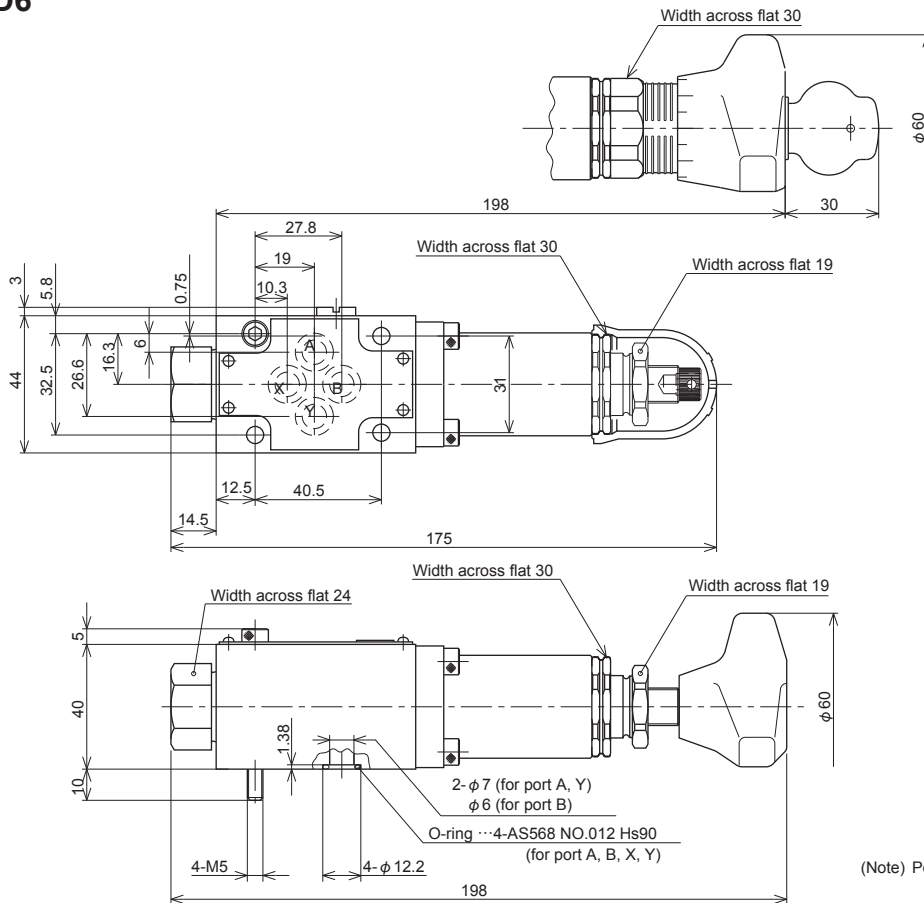

● Handle with key adjusting type

● Screw adjusting type

● Handle adjusting type

(Note) Port X is not connected to the inside of the valve.

●PRD10

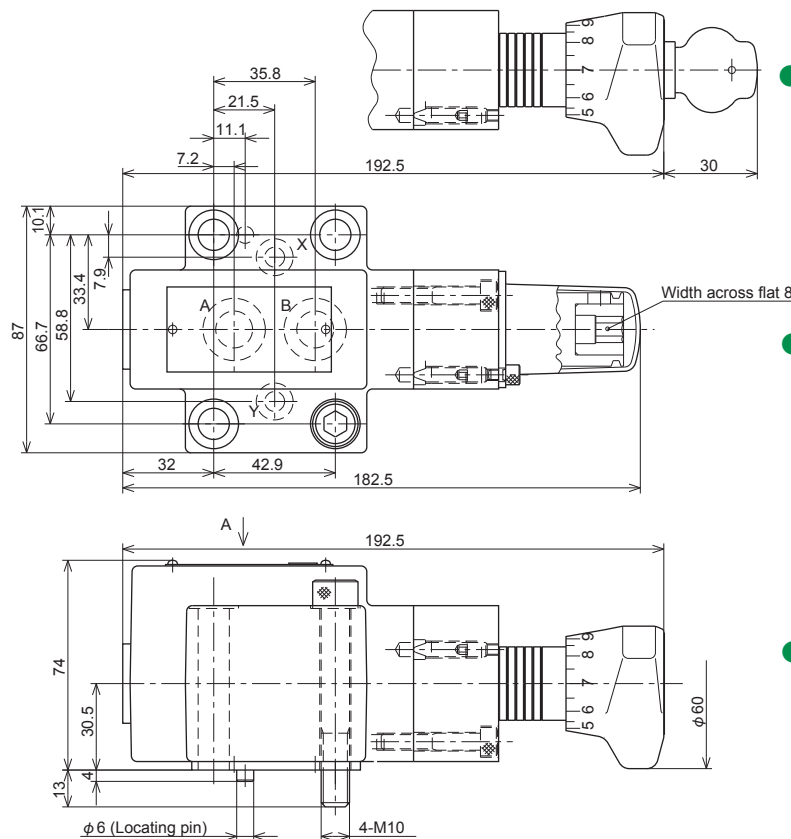

● Handle with key adjusting type

● Screw adjusting type

● Handle adjusting type

Port position	φD	φd	t	O-ring dimension
X Y	13	7	1.4	JIS B2401 P10 Hs90
A B	22	13	1.8	JIS B2401 P18 Hs90

(Note) Port X can be used without a seal since it is not connected to the inside of the valve.

(Note) Port X is not connected to the inside of the valve.

Pressure reducing valve – Direct operated type

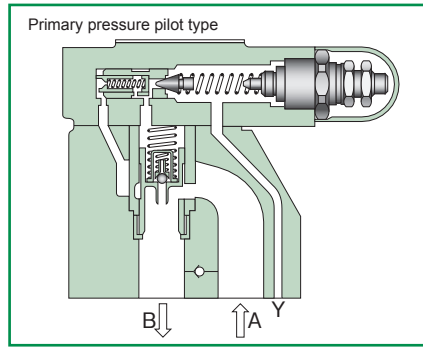
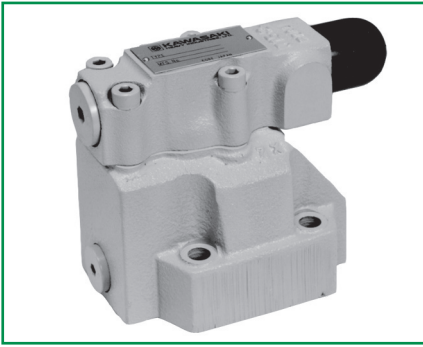

Overview

This balanced piston type pilot operated pressure reducing valve is used for reducing the pressure of the hydraulic circuit partly. Even if the pressure of the main circuit on the primary side fluctuates, it is possible to keep the circuit pressure on the secondary side (low pressure side) at the specified pressure.

Features

- As nominal dimension #10 leads the pilot pressure from the secondary side, the structure is compact.
- As nominal dimension #20 and 30 lead the pilot pressure from the primary side, the maximum flow rate is large and besides they can control the secondary pressure stably.
- When the remote control valve is connected to the drain port, the secondary pressure can be controlled by remote control.

Type indication

PRB

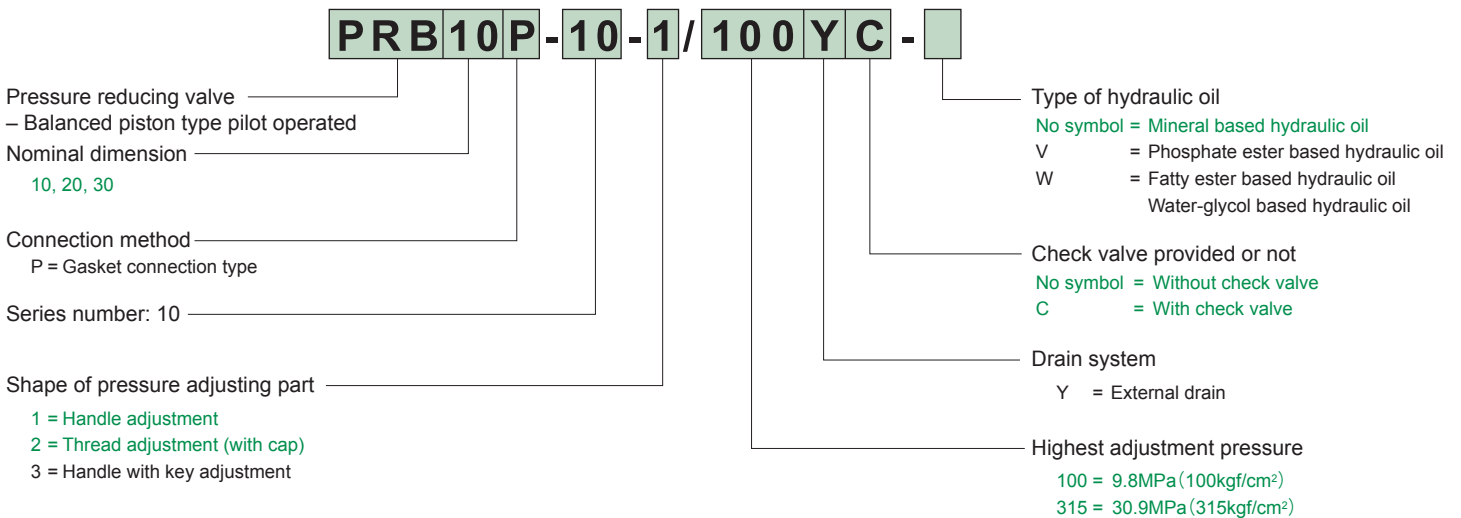

Hydraulic symbols

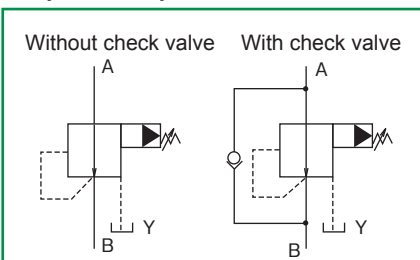

Specifications

Nominal dimension	10	20	30
Maximum working pressure (port A, B, Y) MPa (kgf/cm ²)	30.9(315)		
Maximum flow rate L/min	80	200	300
Highest adjustment pressure MPa (kgf/cm ²)	9.8(100), or 30.9(315)		
Mass kg	3.6	5.5	8.2

(Note) As the minimum adjustment pressure varies depending on the flow rate, refer to "Minimum adjustment pressure characteristics on the secondary side".

Pressure override characteristics (viscosity 36 mm²/s (cSt))

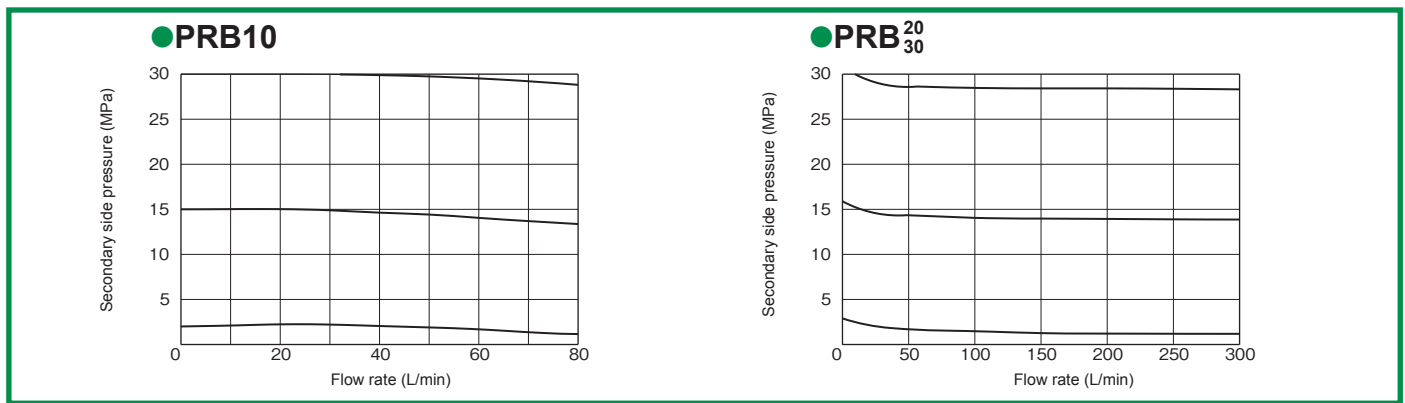

Pressure drop characteristics (viscosity 36 mm²/s (cSt)) in the case of check valve free flow

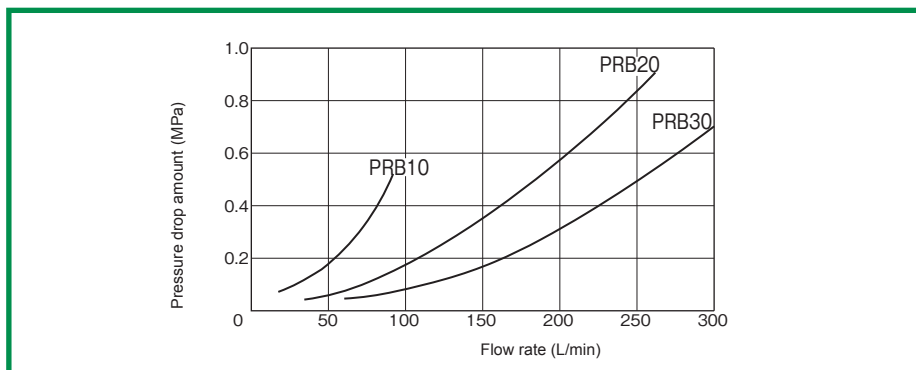

Pilot valve

The pilot valve used for the pressure reducing valve – balanced piston type pilot operated is as follows. If you need the pilot valve only, please specify “pilot valve type” and contact us.

Nominal dimension	Pilot valve type
10	RB10X-10-*/ ¹⁰⁰ / ₃₁₅ (Note)
20, 30	PRB20X-10-*/ ¹⁰⁰ / ₃₁₅

Same as the pilot relief valve for RB10, 20 and 30

(Note) The pressure adjusting system is shown.

- 1 = Handle adjusting type
- 2 = Thread adjusting type (with cap)
- 3 = Handle with key adjusting type

PRB20X

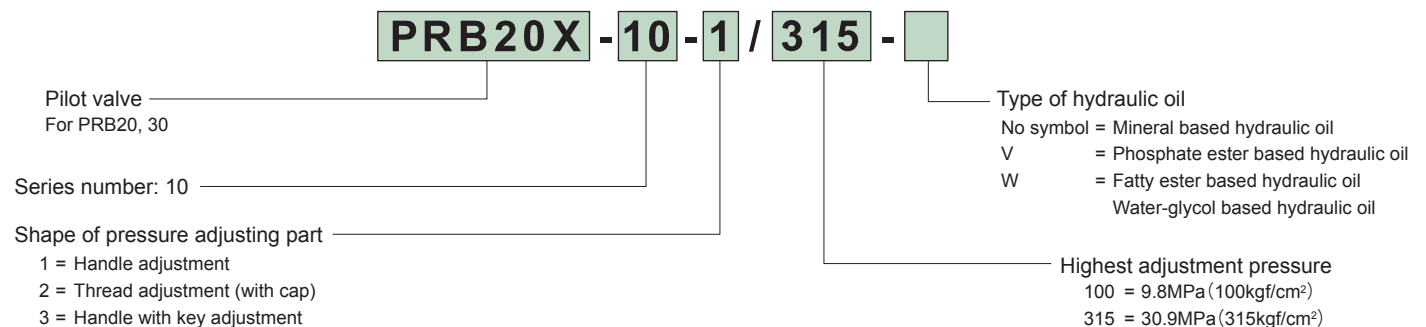

Secondary side minimum adjustment pressure characteristics (viscosity 36 mm²/s (cSt))

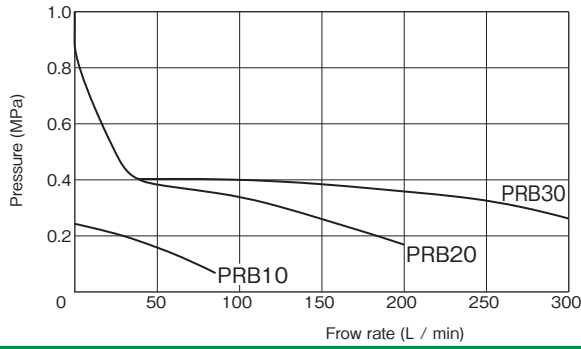

Pressure increase value per turn (clockwise) of adjust thread MPa (kgf/cm²)

Highest adjustment pressure	Nominal dimension	10, 20, 30
100		1.75 (17.8)
315		14.1 (143.9)

(Note) As the above value is a calculated value, there are slight variations in the product.

Sub-plate

Valve type	Sub-plate type	Connection diameter	Mass
PRB10	P-CHY10R14-0	Rc 1/4	2.1kg
	P-CHY10G14-0	G 1/4	
	P-CHY10R38-0	Rc 3/8	
	P-CHY10G38-0	G 3/8	
	P-CHY10R12-0	Rc 1/2	
PRB20	P-CHY10G12-0	G 1/2	4.4kg
	P-CHY20R34-0	Rc 3/4	
	P-CHY20G34-0	G 3/4	
	P-CHY20R1-0	Rc 1	
PRB30	P-CHY20G1-0	G 1	6.9kg
	P-CHY30R54-0	Rc 1 1/4	
	P-CHY30G54-0	G 1 1/4	
	P-CHY30R32-0	Rc 1 1/2	
	P-CHY30G32-0	G 1 1/2	

Accessories

Mounting bolt

Type	Hexagon socket head cap thread	Quantity	Tightening torque N·m (kgf·cm)
PRB10	M10×40L	4 pcs.	56.8±8.5(580±87)
PRB20	M10×50L	4 pcs.	
PRB30	M10×60L	6 pcs.	

When you use a sub-plate, please place an order for the above sub-plate type. For the dimension drawing, refer to page 6, 7 of the appendix.

Dimension drawing

PRB

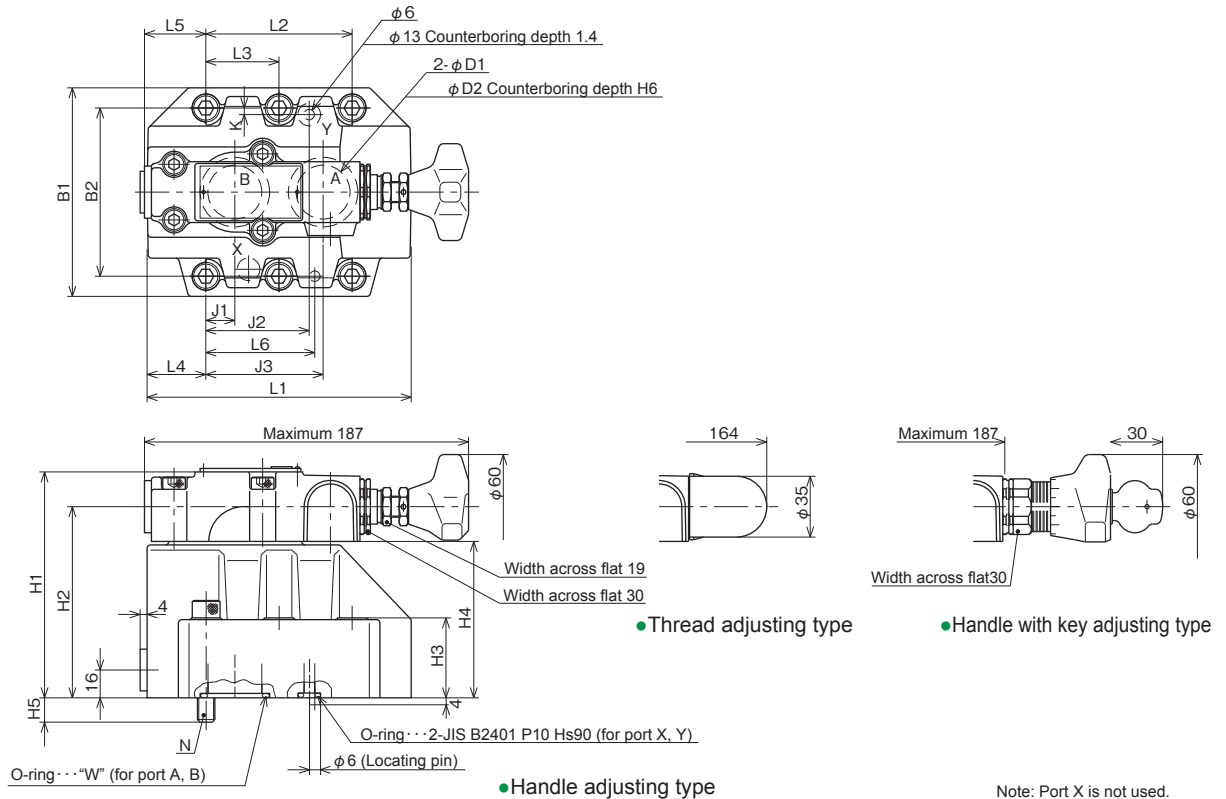

Nominal dimension	B1	B2	N	D1	D2	H1	H2	H3	H4	H5	H6	L1	L2	L3	L4	L5	L6	O-ring dimension "W"	J1	J2	J3	K
10	85	66.7	4-M10	15	22	112	92	28	72	12	1.8	104	42.9	—	35.5	38.5	31.8	2-JIS B2401 P18 HS90	7.2	21.5	35.8	7.9
20	102	79.4		25	35	122	102	38	82		2.4	121	60.3	—	33.5	41	44.5	2-JIS B2401 G30 HS90	11.1	39.7	49.2	6.4
30	120	96.8	6-M10	34	40	130	110	46	90	14	153	84.2	42.1	34	35.3	62.7	2-JIS B2401 G35 HS90	16.7	59.5	67.5	3.8	

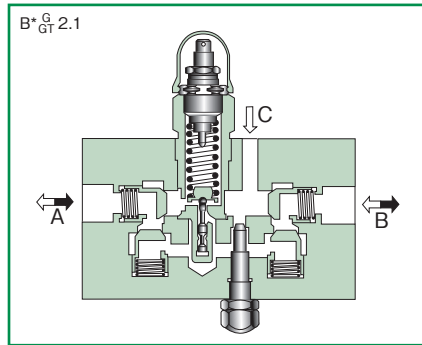
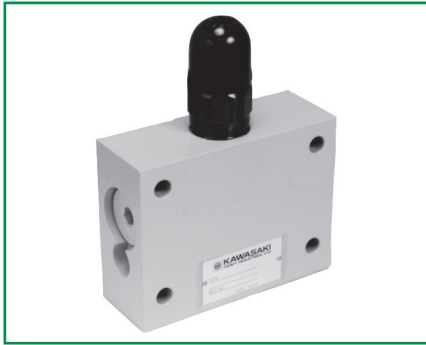

Overview

This brake valve is an arbitrary combination of the direct operated type relief valve, check valve, bypass valve and so on, and is used to eliminate shocks that occur when an actuator such as a hydraulic motor starts and stops.

Features

- As the direct operated type relief valve is used, the responsiveness is good and the internal leakage amount is small.
- There are a variety of circuit types. (with bypass valve, with check valve for anti-cavitation)

Type indication

B 10 P 2 . 2 - 10 / 100 -

<p>Brake valve</p> <p>Nominal dimension 10, 15, 20, 25, 30</p> <p>Connection method P = Gasket connection type (in the case of nominal dimension of 10, 20, 30) G = G thread connection type GT = R thread connection type</p> <p>Shape of pressure adjusting part 1 = Handle adjustment 2 = Thread adjustment (with cap) 3 = Handle with key adjustment*</p> <p>*Nominal dimension 25 and 30 have no handle.</p>	<p>Type of hydraulic oil No symbol = Mineral based hydraulic oil V = Phosphate ester based hydraulic oil W = Fatty ester based hydraulic oil Water-glycol based hydraulic oil</p> <p>Highest adjustment pressure 25 = 2.5MPa (25kgf/cm²) 50 = 4.9MPa (50kgf/cm²) 100 = 9.8MPa (100kgf/cm²) 200 = 19.6MPa (200kgf/cm²) 315 = 30.9MPa (315kgf/cm²)</p> <p>Series number: 10</p> <p>Circuit configuration symbol 1 = Types with short circuit valve (Hydraulic symbols) (1) 2 = Types without short circuit valve (Hydraulic symbols) (2) 3 = Types with short circuit valve (Hydraulic symbols) (3) 4 = Types without short circuit valve (Hydraulic symbols) (4)</p>
---	---

Hydraulic symbols

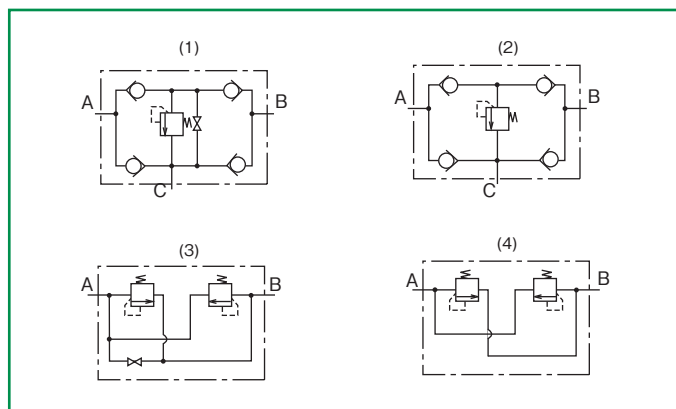

● The direct operated type relief valve used for this brake valve is as follows.

Nominal dimension	Type of direct operated type relief valve
10	RD10C-*
15, 20	RD20C-*
25, 30	RD30C-*

Specifications

Nominal dimension		10	15	20	25	30		
Maximum working pressure MPa (kgf/cm ²) (port A, B)		30.9 (315)						
Maximum flow rate (L/min) (Note)		110	230	330				
Cracking pressure MPa (kgf/cm ²)		0.05 (0.5)						
Mass kg	Thread connection type	Circuit configuration symbol	1	7.0	18	20	43	52
			2	7.0	15	19	42	50
			3	7.5	16.5	16.5	31.5	31.5
			4	5.5	11	11	21	21
	Gasket connection type	Circuit configuration symbol	1	7.0	—	15	—	42
			2	5.0	—	15	—	42
			3	7.5	—	15.5	—	31
			4	5.5	—	11	—	21

(Note) As the maximum flow rate differs depending on the set pressure, refer to "Pressure override characteristics".

Accessories

● Mounting bolt

Type	Hexagon socket head cap thread	Quantity	Tightening torque N·m (kgf·cm)
B10P*-1	M10×80L	4 pcs.	56.8±8.5(580±87)
B20P*-1	M16×115L	4 pcs.	235.2±35.2(2400±360)
B30P*-1	M20×155L	4 pcs.	431.2±64.6(4400±660)
B10P*-2	M10×65L	4 pcs.	56.8±8.5(580±87)
B20P*-2	M16×115L	4 pcs.	235.2±35.2(2400±360)
B30P*-2	M20×155L	4 pcs.	431.2±64.6(4400±660)
B10P*-3	M8×85L	4 pcs.	29.4±4.4(300±45)
B20P*-3	M12×105L	4 pcs.	98.0±14.7(1000±150)
B30P*-3	M16×135L	4 pcs.	235.2±35.2(2400±360)
B10P*-4	M8×65L	4 pcs.	29.4±4.4(300±45)
B20P*-4	M12×80L	4 pcs.	98.0±14.7(1000±150)
B30P*-4	M16×100L	4 pcs.	235.2±35.2(2400±360)

Pressure override characteristics

● This is similar to that of the relief valve – direct operated type.
Refer to the section of the type number index "RD10, 20, 30".

Dimension drawing

● B*G/GT* · 1

● Handle adjusting type

(in the case of nominal dimension other than 25, 30)

● Screw adjusting type

● Handle with key adjusting type

(in the case of nominal dimension of 10, 15, 20)

● Handle adjusting type

(in the case of nominal dimension of 25, 30)

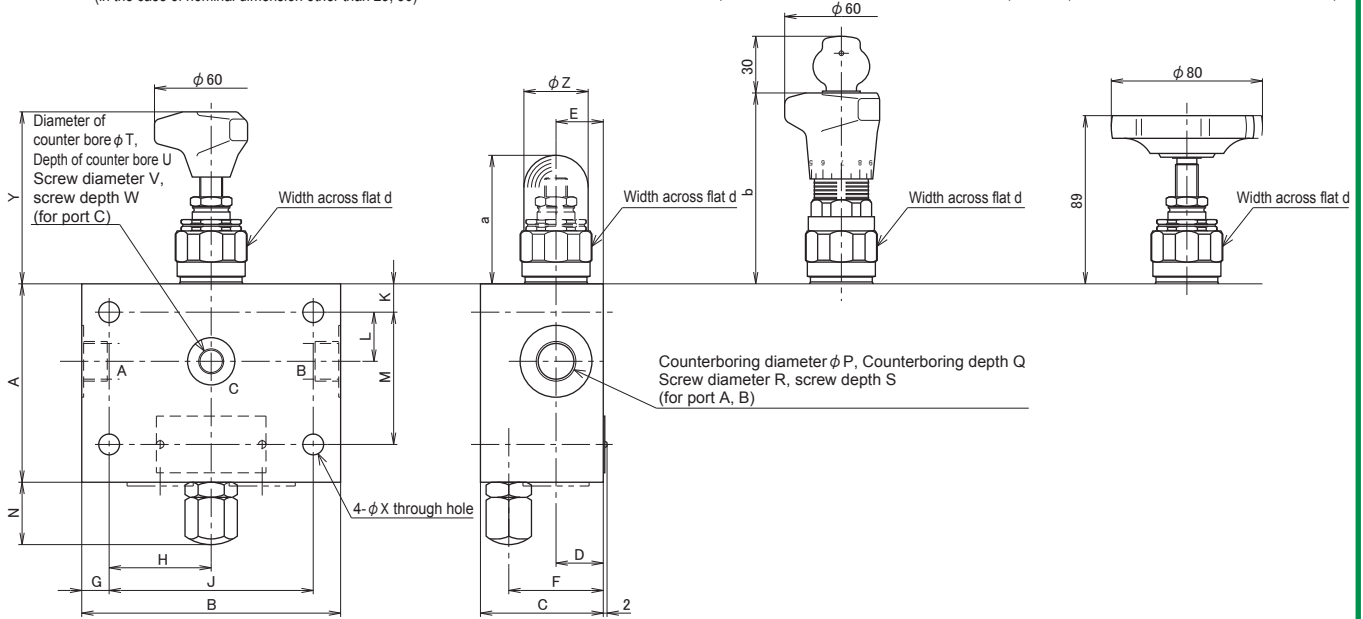

Nominal dimension	A	B	C	D	E	F	G	H	J	K	L	M	N	P	Q	R	S	T	U	V	W	X	Y	Z	a	b	d	
10	G	105	137	65	25	25	50	14.5	54	108	15	26	70	33	38	1	G 1/2	12.5	25	1	G 1/4	16	11	91	35	68	91	36
	GT																Rc 1/2	12.5			Rc 1/4	12.5						
15	G	130	185	100	42	62	20	14	78.5	157	14	40	102	33	45	1	G 3/4	21	32	1	G 3/8	14	11	88	40	65	88	46
	GT																Rc 3/4	19			Rc 3/8	14						
20	G	133	188	110	45	70	20	24	70	140	14	40	105	37	52	1	G1	19	38	1	G 1/2	19	11					
	GT																Rc1	19			Rc 1/2	17						
25	G	185	250	125	40	73	35	20	105	210	20	42	145	33	63	1	G1 1/4	28	52	1	G1	24	14					
	GT																Rc1 1/4	24.5			Rc1	22	14					
30	G	180	285	135	42	86	42	20	122.5	245	20	43	140	33	65	1	G1 1/2	26	52	1	G1	20	14					
	GT																Rc1 1/2	25.5			Rc1	22						

● B*G/GT* · 2

● Handle adjusting type

(in the case of nominal dimension other than 25, 30)

● Screw adjusting type

● Handle with key adjusting type

(in the case of nominal dimension of 10, 15, 20)

● Handle adjusting type

(in the case of nominal dimension of 25, 30)

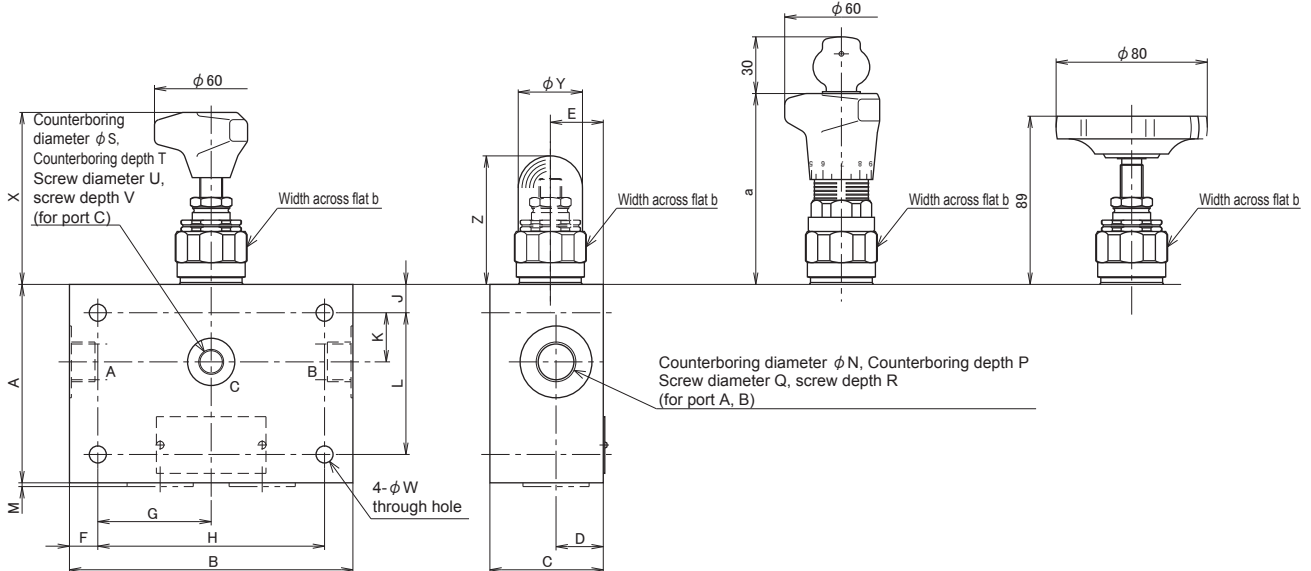

Nominal dimension	A	B	C	D	E	F	G	H	J	K	L	M	N	P	Q	R	S	T	U	V	W	X	Y	Z	a	b	
10	G	105	150	60	25	28	15	60	120	15	26	75	0	38	1	G 1/2	15	25	1	G 1/4	15	9	91	35	68	91	36
	GT															Rc 1/2	15			Rc 1/4	12.5						
15	G	130	185	85	27	47	14	78.5	157	14	40	102	2	45	1	G 3/4	21	32	1	G 3/8	14	11	88	40	65	88	46
	GT															Rc 3/4	19			Rc 3/8	14						
20	G	133	188	100	35	60	24	70	140	14	40	105	8	52	1	G1	19	38	1	G 1/2	19	11					
	GT															Rc1	19			Rc 1/2	17						
25	G	185	250	125	40	73	20	105	210	20	42	145	1.5	63	1	G1 1/4	28	52	1	G1	24	14					
	GT															Rc1 1/4	24.5			Rc1	22	14					
30	G	180	285	135	42	86	20	122.5	245	20	43	140	4	65	1	G1 1/2	26	52	1	G1	20	14					
	GT															Rc1 1/2	25.5			Rc1	22						

●B*G/GT* - 3

●Handle adjusting type

(in the case of nominal dimension other than 25, 30)

●Screw adjusting type

●Handle with key adjusting type

(in the case of nominal dimension of 10, 15, 20)

●Handle adjusting type

(in the case of nominal dimension of 25, 30)

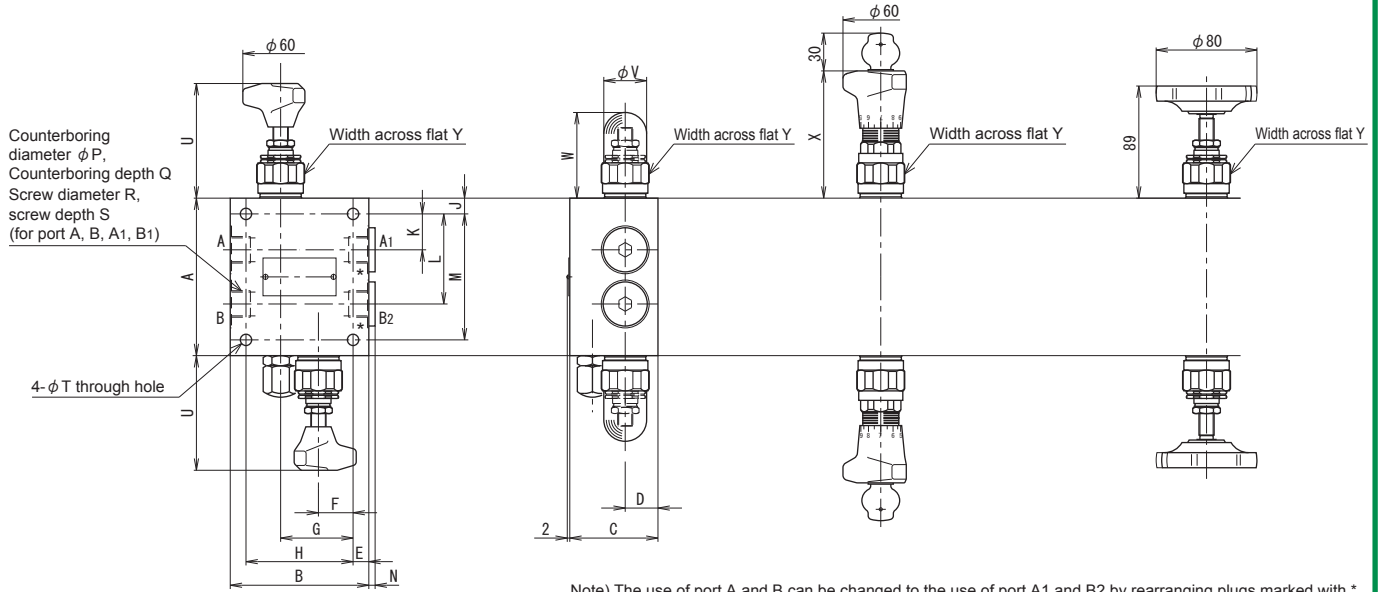

Note) The use of port A and B can be changed to the use of port A1 and B2 by rearranging plugs marked with *.

Nominal dimension	A	B	C	D	E	F	G	H	J	K	L	M	N	P	Q	R	S	T	U	V	W	X	Y	
10	G	125	110	70	26	12.5	27.5	57.5	85	12.5	28.5	71.5	100	5	38	1	G 1/2	15	9	91	35	68	91	36
	—													—	—	Rc 1/2	15							
15	G	170	145	85	30	12	42	79	121	20	34	96	130	5	45	1	G 3/4	21	14	88	40	65	88	46
	GT													—	—	Rc 3/4	19							
20	G	170	145	85	30	12	42	79	121	20	34	96	130	8	52	1	G1	21	14	88	40	65	88	46
	GT													—	—	Rc1	21							
25	G	196	185	110	37.5	17.5	48.5	101.5	150	20	40	116	156	6	—	—	G1 1/4	25	14	—	50	83	—	60
	GT													—	—	Rc1 1/4	24.5							
30	G	196	185	110	37.5	17.5	48.5	101.5	150	20	40	116	156	6	—	—	G1 1/2	25	14	—	50	83	—	60
	GT													—	—	Rc1 1/2	25							

●B*G/GT* - 4

● Handle adjusting type
(in the case of nominal dimension other than 25, 30)

● Screw adjusting type

● Handle with key adjusting type

● Handle adjusting type
(in the case of nominal dimension of 25, 30)

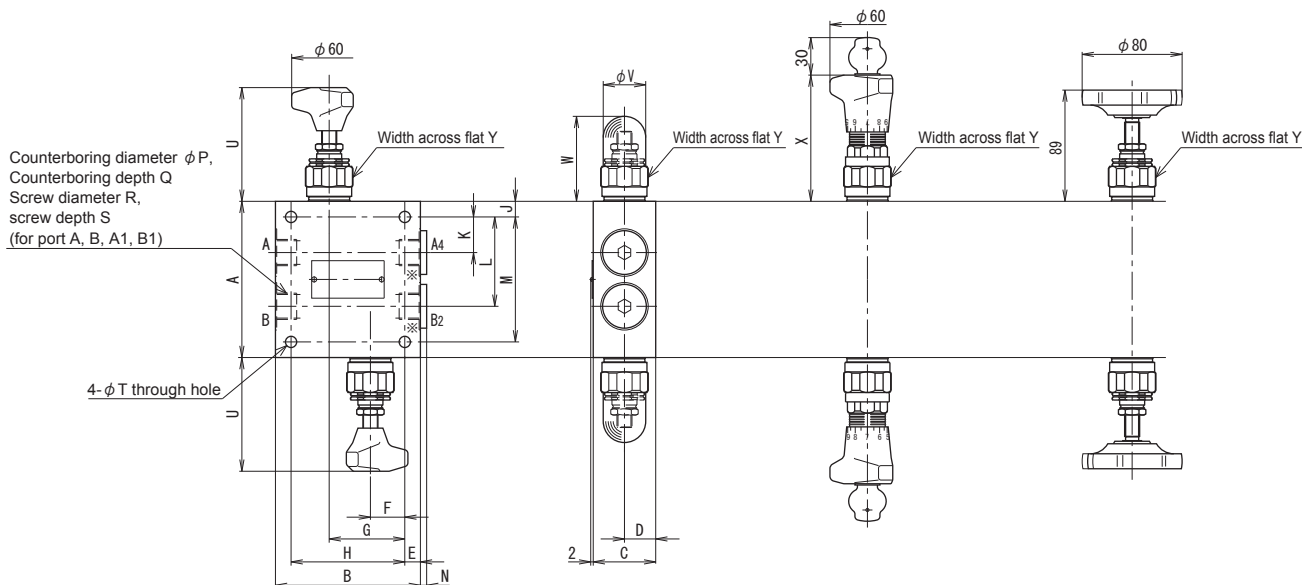

Note) The use of port A and B can be changed to the use of port A1 and B2 by rearranging plugs marked with *.

Nominal dimension		A	B	C	D	E	F	G	H	J	K	L	M	N	P	Q	R	S	T	U	V	W	X	Y
10	G	125	116	50	25	12.5	30.5	60.5	91	12.5	28.5	71.5	100	5	38	1	G $\frac{1}{2}$	17	9	91	35	68	91	36
	—													—	—	Rc $\frac{1}{2}$	17							
15	G	170	145	60	30	12	42	79	121	20	34	96	130	5	45	1	G $\frac{3}{4}$	21	14	88	40	65	88	46
	—													—	—	Rc $\frac{3}{4}$	19							
20	G	170	145	60	30	12	42	79	121	20	34	96	130	8	52	1	G1	21	14	88	40	65	88	46
	—													—	—	Rc1	21							
25	G	196	185	75	37.5	17.5	48.5	101.5	150	20	40	116	156	6	—	—	G1 $\frac{1}{4}$	25	14	—	50	83	—	60
	—													—	—	Rc1 $\frac{1}{4}$	24.5							
30	G	196	185	75	37.5	17.5	48.5	101.5	150	20	40	116	156	6	—	—	G1 $\frac{1}{2}$	25	14	—	50	83	—	60
	—													—	—	Rc1 $\frac{1}{2}$	25							

Brake valve

●B*P*.1

●Handle adjusting type

(in the case of nominal dimension other than 30)

●Screw adjusting type

●Handle with key adjusting type

(in the case of nominal dimension of 10, 20)

●Handle adjusting type

(in the case of nominal dimension of 30)

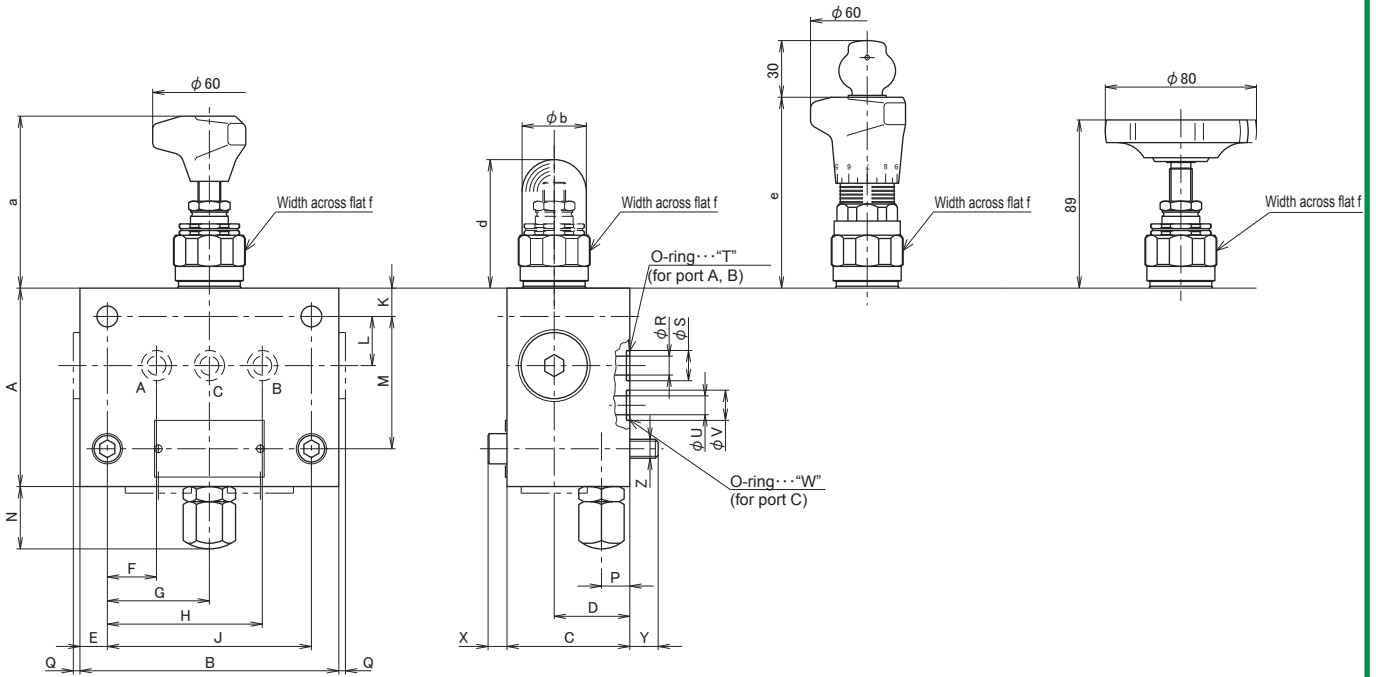

Nominal dimension	A	B	C	D	E	F	G	H	J	K	L	M	N	P	Q	R	S	O-ring dimension "T"	U	V	O-ring dimension "W"	X	Y	Z	a	b	d	e	f
10	105	137	65	40	14.5	26	54	82	108	15	26	70	33	15	0	10	16	2-JIS B2401 P12 Hs90	10	16	2-JIS B2401 P12 Hs90	10	15	4-M10	91	35	68	91	36
20	133	168	90	60	14	35	70	105	140	14	40	105	37	20	3.5	20	26	2-JIS B2401 P22 Hs90	20	26	2-JIS B2401 P22 Hs90	16	25	4-M16	88	40	65	88	46
30	185	250	125	75	20	55	105	155	210	20	50	145	33	35	5	30	40	2-JIS B2401 G35 Hs90	18	26	2-JIS B2401 P22 Hs90	20	30	4-M20	-	50	83	-	60

●B*P*.2

●Handle adjusting type

(in the case of nominal dimension other than 30)

●Screw adjusting type

●Handle with key adjusting type

(in the case of nominal dimension other than 10, 20)

●Handle adjusting type

(in the case of nominal dimension of 30)

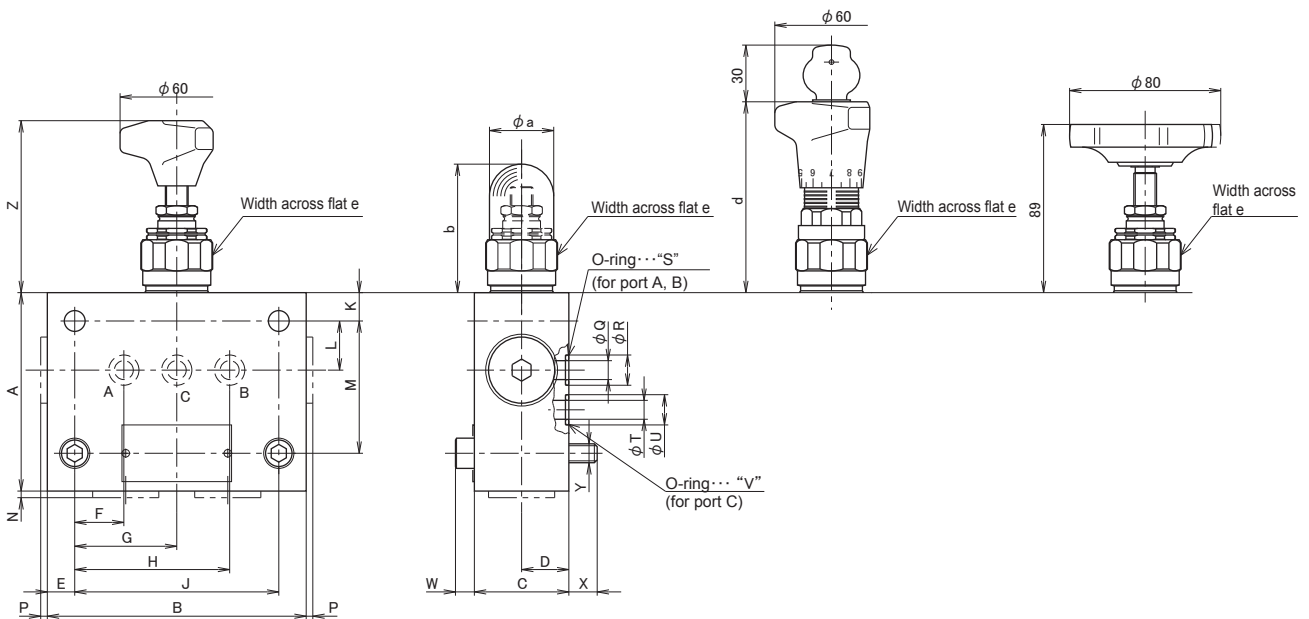

Nominal dimension	A	B	C	D	E	F	G	H	J	K	L	M	N	P	Q	R	S	O-ring dimension "S"	T	U	O-ring dimension "V"	W	X	Y	Z	a	b	d	e
10	105	137	50	25	14.5	26	54	82	108	15	26	70	0	0	10	16	2-JIS B2401 P12 Hs90	10	16	2-JIS B2401 P12 Hs90	10	15	4-M10	91	35	68	91	36	
20	133	168	90	60	14	35	70	105	140	14	40	105	8	3.5	20	26	2-JIS B2401 P22 Hs90	20	26	2-JIS B2401 P22 Hs90	16	25	4-M16	88	40	65	88	46	
30	185	250	125	75	20	55	105	155	210	20	50	145	0	5	30	40	2-JIS B2401 G35 Hs90	18	26	2-JIS B2401 P22 Hs90	20	30	4-M20	-	50	83	-	60	

●B*P*.3

●Handle adjusting type

(in the case of nominal dimension other than 30)

●Screw adjusting type

●Handle with key adjusting type

(in the case of nominal dimension of 10, 20)

●Handle adjusting type

(in the case of nominal dimension of 30)

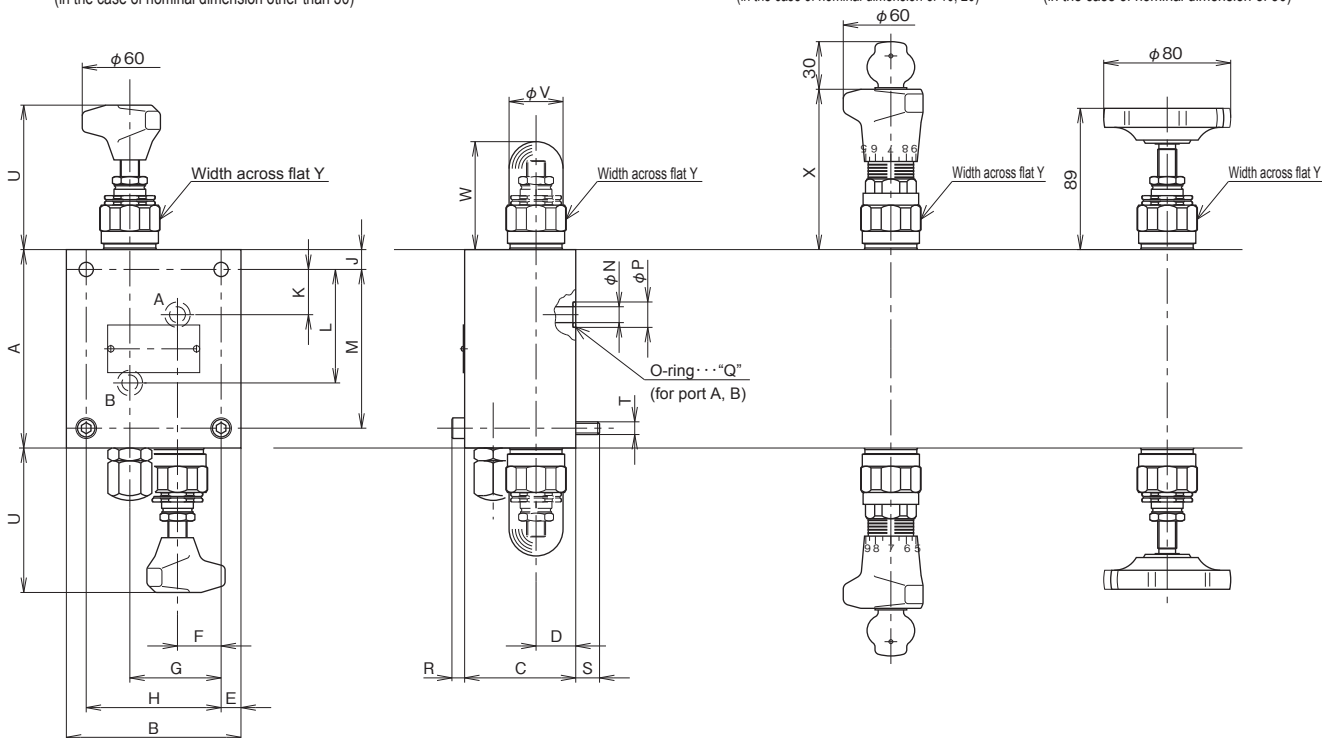

Nominal dimension	A	B	C	D	E	F	G	H	J	K	L	M	N	P	O-ring dimension "Q"	R	S	T	U	V	W	X	Y
10	125	110	70	25	12.5	27.5	57.5	85	12.5	28.5	71.5	100	10	16	2-JIS B2401 P12 Hs90	8	15	4-M8	91	35	68	91	36
20	170	145	85	30	12	42	79	121	20	34	96	130	20	26	2-JIS B2401 P22 Hs90	12	20	4-M12	88	40	65	88	46
30	195	185	110	37.5	17.5	47.5	102.5	150	20	40	115	155	30	40	2-JIS B2401 G35 Hs90	16	25	4-M16	-	50	83	-	60

●B*P*.4

●Handle adjusting type

(in the case of nominal dimension other than 30)

●Screw adjusting type

●Handle with key adjusting type

(in the case of nominal dimension of 10, 20)

●Handle adjusting type

(in the case of nominal dimension of 30)

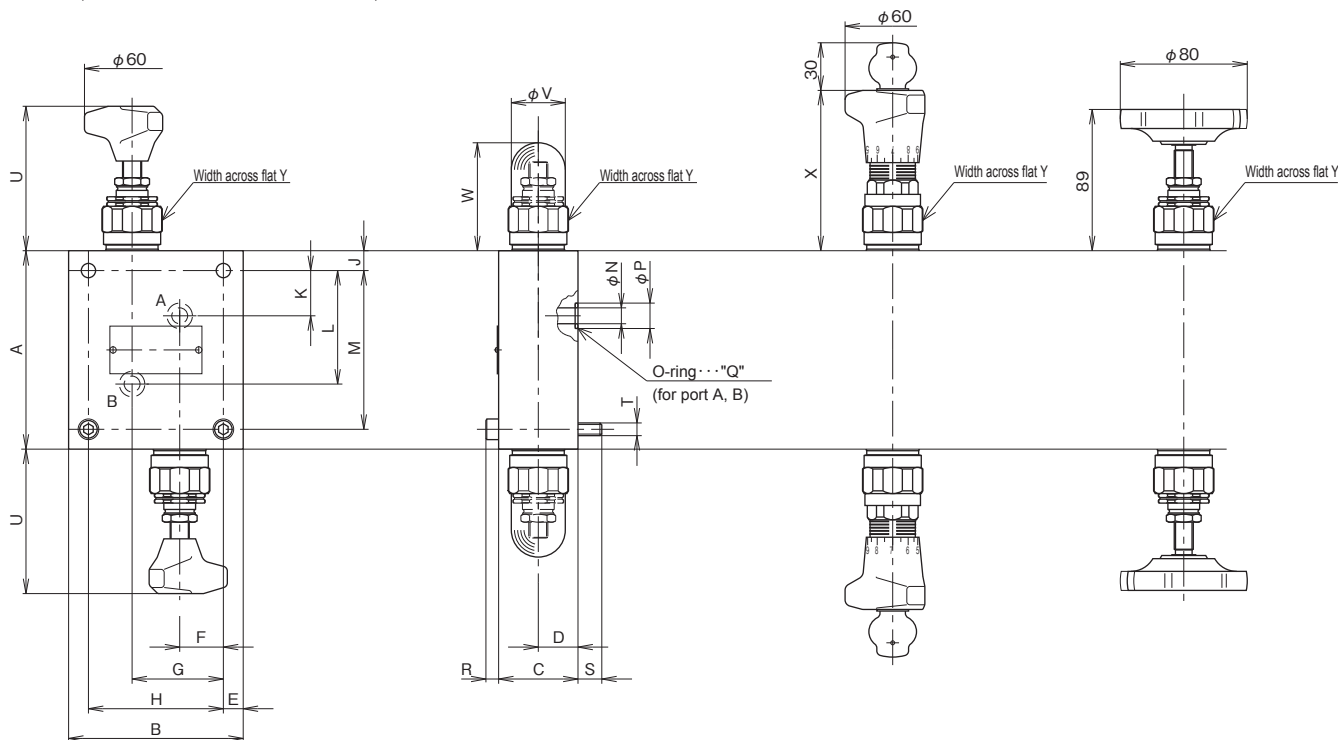

Nominal dimension	A	B	C	D	E	F	G	H	J	K	L	M	N	P	O-ring dimension "Q"	R	S	T	U	V	W	X	Y
10	125	110	50	25	12.5	27.5	57.5	85	12.5	28.5	71.5	100	10	16	2-JIS B2401 P12 Hs90	8	15	4-M8	91	35	68	91	36
20	170	145	60	30	12	42	79	121	20	34	96	130	20	26	2-JIS B2401 P22 Hs90	12	20	4-M12	88	40	65	88	46
30	195	185	75	37.5	17.5	47.5	102.5	150	20	40	115	155	30	40	2-JIS B2401 G35 Hs90	16	25	4-M16	-	50	83	-	60

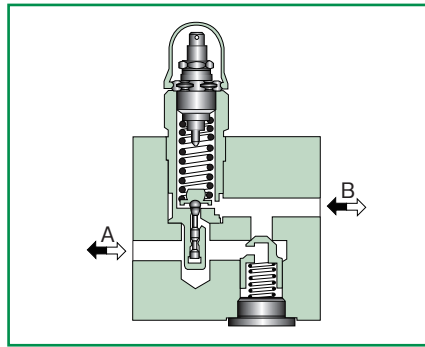
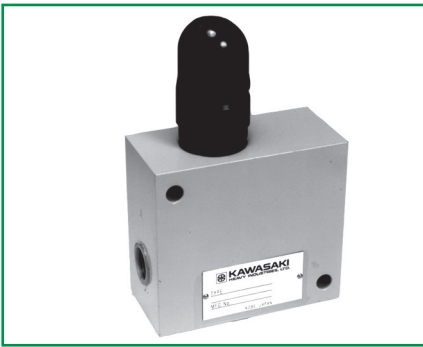

Overview

This counterbalance valve is a combination of the direct operated type relief valve and check valve and is used to hold the load by providing a counterbalance pressure.

When the counterbalance valve raises the hydraulic cylinder, it allows oil to pass freely and when it lowers the cylinder, it generates pressure in the return pipe to prevent the cylinder weight fall.

Features

1. As this is a combination of the seat type relief valve and check valve, leakage is small.
2. As the direct operated type relief valve is used, there is no overlap allowance unlike other valves. Therefore, no confinement pressure occurs and smooth operation can be provided.

Type indication

CBD 10 P - 10 - 1 / 315 -

Counterbalance valve
– direct operated type

Nominal dimension
6, 10, 15, 20, 25, 30

Connection method

- P = G asket connection type
- G = G thread connection type
- R = R thread connection type

Nominal dimension	P	G	R
6	—	○	○
10	○	○	○
15	—	○	○
20	○	○	○
25	—	○	○
30	○	○	○

Series number: 10

Type of hydraulic oil

- No symbol = Mineral based hydraulic oil
- V = Phosphate ester based hydraulic oil
- W = Fatty ester based hydraulic oil
- Water-glycol based hydraulic oil

Highest adjustment pressure

- 25 = 2.5MPa(25kgf/cm²)
- 50 = 4.9MPa(50kgf/cm²)
- 100 = 9.8MPa(100kgf/cm²)
- 200 = 19.6MPa(200kgf/cm²)
- 315 = 30.9MPa(315kgf/cm²)

Shape of pressure adjusting part

- 1 = Handle adjustment
- 2 = Thread adjustment (with cap)
- 3 = Handle with key adjustment
(nominal dimension 6, 10, 15, 20 only)

● The direct operated type relief valve used for this counterbalance valve is as follows.

Nominal dimension	Type of direct operated type relief valve
6, 10	RD10C-*
15, 20	RD20C-*
25, 30	RD30C-*

Hydraulic symbols

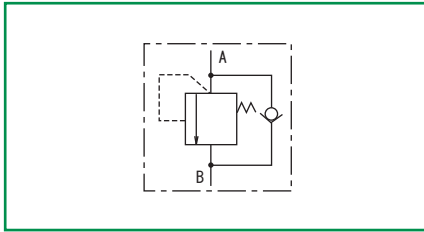

Specifications

Nominal dimension	6	10	15	20	25	30
Maximum working pressure MPa (kgf/cm ²) (Port A, B)	30.9 (315)					
Maximum flow rate L/min	45	110	230	330		
Cracking pressure MPa (kgf/cm ²)	0.05 (0.5)					
Mass kg	4		9		20	

(Note) As the maximum flow rate differs depending on the set pressure, refer to "Pressure override characteristics".

Pressure drop characteristics (viscosity 36 mm²/s (cSt)) in the case of check valve free flow

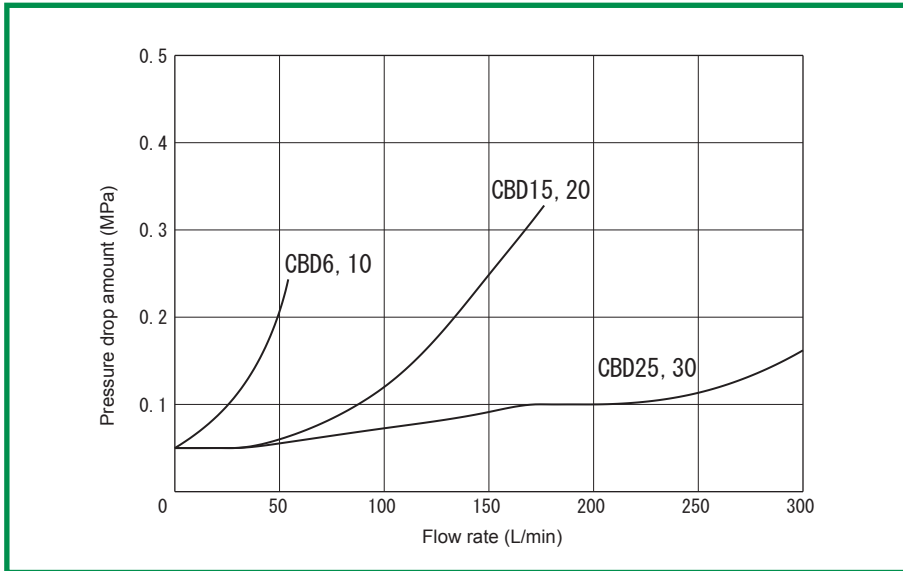

Accessories

Mounting bolt

Type	Hexagon socket head cap thread	Quantity	Tightening torque N·m (kgf·cm)
CBD10P	M8×65L	4 pcs.	29.4 ± 4.4 (300 ± 45)
CBD20P	M12×80L	4 pcs.	98.0 ± 14.7 (1000 ± 150)
CBD30P	M16×105L	4 pcs.	235.2 ± 35.2 (2400 ± 360)

Pressure override characteristics

- This is similar to that of the relief valve – direct operated type.
Refer to the section of the type number index "RD10, 20, 30".

Dimension drawing

● CBD*G/R

● Handle adjusting type

(in the case of nominal dimension other than 25, 30)

● Screw adjusting type

● Handle with key adjusting type

● Handle adjusting type

(in the case of nominal dimension of 25, 30)

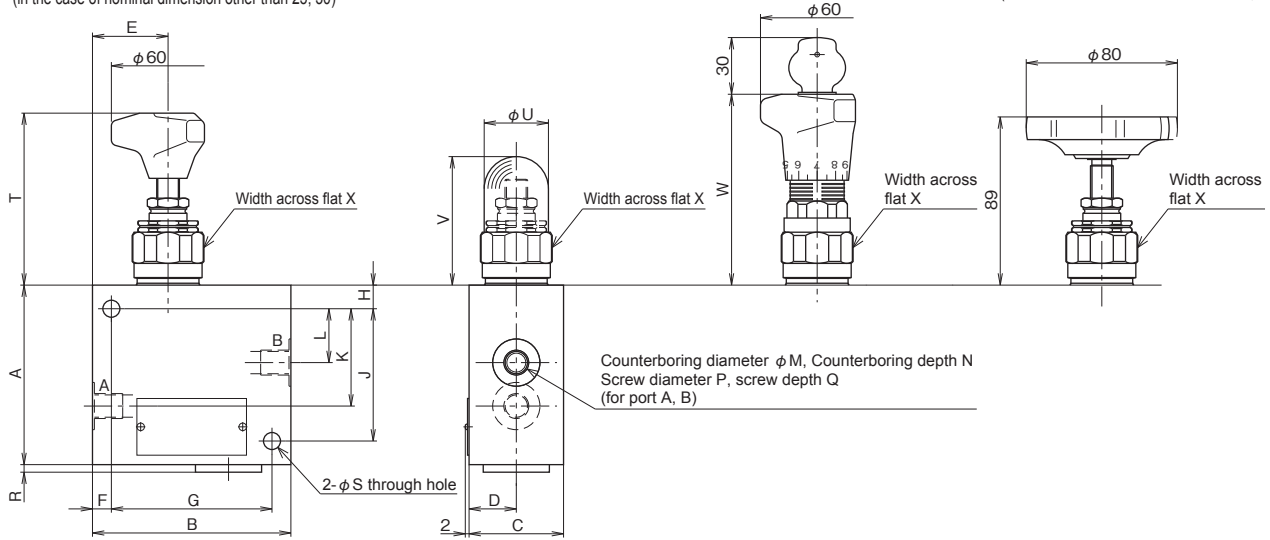

Nominal dimension	A	B	C	D	E	F	G	H	J	K	L	M	N	P	Q	R	S	T	U	V	W	X	
6	G											25	1	G 1/4	16								
	R	95	105	50	25	40	10	85	12.5	70	51.5	—	—	Rc 1/4	12.5	4	9	91	35	68	91	36	
10	G											38	1	G 1/2	15								
	R											—	—	Rc 1/2	15								
15	G											45	1	G 3/4	18								
	R	135	140	60	30	50	15	110	20	95	70	—	—	Rc 3/4	19	7	14	88	40	65	88	46	
20	G											52	1	G 1	20								
	R											—	—	Rc 1	20								
25	G											63	1	G 1 1/4	23								
	R	175	180	80	40	60	15	150	20	135	90	—	—	Rc 1 1/4	23	3	18	—	50	83	—	60	
30	G											65	1	G 1 1/2	23								
	R											—	—	Rc 1 1/2	23								

● CBD*P

● Handle adjusting type

(in the case of nominal dimension other than 30)

● Screw adjusting type

● Handle with key adjusting type

(in the case of nominal dimension of 10, 20)

● Handle adjusting type

(in the case of nominal dimension of 30)

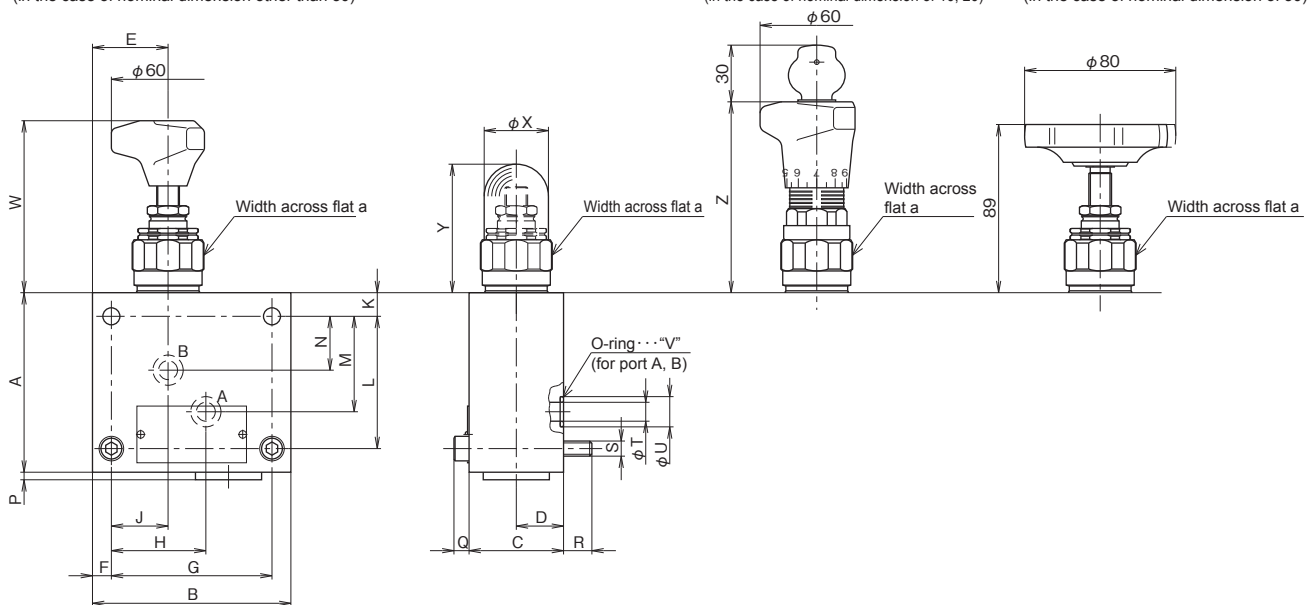

Nominal dimension	A	B	C	D	E	F	G	H	J	K	L	M	N	P	Q	R	S	T	U	O-ring dimension "V"	W	X	Y	Z	a
10	95	105	50	25	40	10	85	50	30	12.5	70	50.5	28.5	4	8	15	4-M8	10	16	2-JIS B2401 P12 Hs90	91	35	68	91	36
20	135	145	60	30	50	15	115	65	35	25	85	63	29	8	12	20	4-M12	20	30	2-JIS B2401 G25 Hs90	88	40	65	88	46
30	175	180	80	40	60	15	150	70	45	25	125	82	35	5	16	25	4-M16	30	40	2-JIS B2401 G35 Hs90	—	50	83	—	60

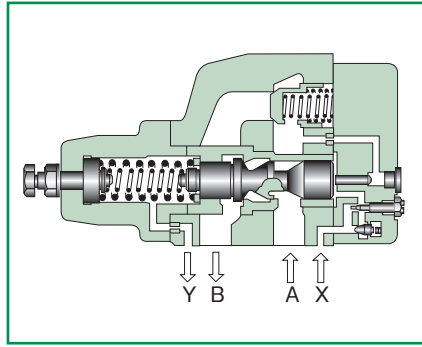
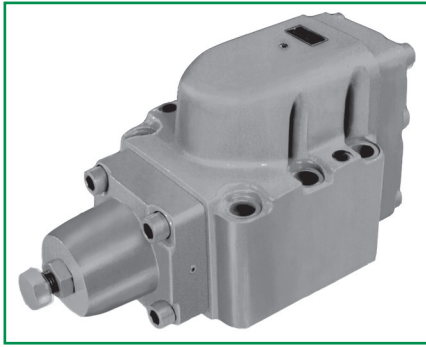

Counterbalance valve – with unloading function

Overview

This counterbalance valve is used to prevent load drop within a cylinder under overrunning load conditions and to control its lowering speed.

Features

- As the spool of the counterbalance valve is provided with the flow control part and seat part together, stable brake pressure can be obtained and at the same the leakage amount is small and the slipping-down amount of ram can be made very small.
- When weight drop (fast feed state) is changed to

- pressurization (slow feed state), ram speed change can be adjusted and smooth operation can be performed by controlling spool valve closing speed with variable throttle.
- The passage in the casing is composed of through holes and the flow resistance is small.

Type indication

KDZ 15 P - 3.2 / 25 - 100 -

Counterbalance valve (with unloading function)

Nominal dimension
15, 25, 40

Connection method
P = Gasket connection type

Series number: 3, 2

Type of hydraulic oil

- No symbol = Mineral based hydraulic oil
- V = Phosphate ester based hydraulic oil
- W = Fatty ester based hydraulic oil
- Water-glycol based hydraulic oil

Brake pressure

- 100 = 0 to 9.8 MPa
- 150 = 7.8 to 14.7 MPa
- 210 = 14.7 to 20.6 MPa (varies depending on self-weight of ram)

Spool notch area symbol

Symbol	Brake flow during pressurization
25	120L/min or less
100	120L/min or more

Hydraulic symbols

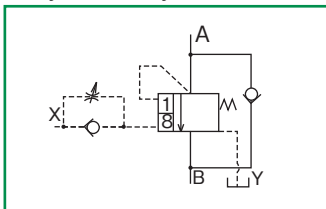

Specifications

Nominal dimension	15	25	40
Maximum working pressure MPa (kgf/cm ²)	24.5(250)		
Maximum flow rate L/min	120	240	500
Cracking pressure MPa (kgf/cm ²)	0.34(3.5)		
Stroke volume of spool cm ³ (during activation of external pilot pressure)	1.9	3.7	10.0
Mass kg	8	13.5	59

Pressure drop characteristics (viscosity 36 mm²/s (cSt))

● In the case of check valve free flow

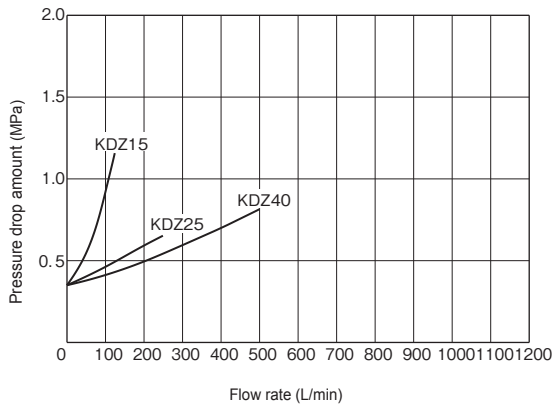

● In case of internal pilot operation
(Pilot pressure 2.5MPa (25kgf/cm²))

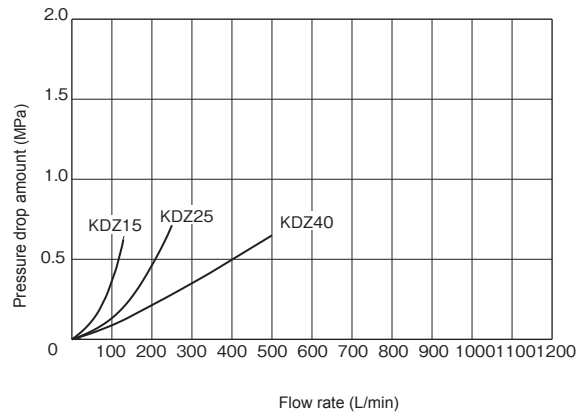

● Pressure increase value per turn (clockwise) of adjust thread MPa (kgf/cm²)

Maximum working pressure	Nominal dimension	15	25	40
100		2.63 (26.8)	2.80 (28.5)	2.62 (26.7)
150		2.63 (26.8)	2.80 (28.5)	2.00 (20.4)
210		2.63 (26.8)	2.80 (28.5)	2.39 (24.4)

(Note) As the above value is a calculated value, there are slight variations in the product.

Minimum external pilot pressure

● The minimum external pilot pressure refers to the external pilot pressure necessary for moving the main spool to the stroke end and fully opening the passage from A to B. The calculation is performed with the following formula.

Type	Minimum external pilot pressure
KDZ15P - * / * - *	(Set pressure for braking period) × $\frac{1}{8.2}$ + 1.1MPa
KDZ25P - * / * - *	(Set pressure for braking period) × $\frac{1}{9.8}$ + 1.2MPa
KDZ40P - * / * - 100 - 150 - 210	(Set pressure for braking period) × $\frac{1}{10.2}$ + 1.3MPa + 1.0MPa + 1.2MPa

Accessories

● Mounting bolt

Type	Hexagon socket head cap thread	Quantity	Tightening torque N·m (kgf·cm)
KDZ15P	M10×80L	4 pcs.	56.8 ± 8.5 (580 ± 87)
KDZ25P	M10×85L	6 pcs.	
KDZ40P	M22×140L	6 pcs.	617.4 ± 92.6 (6300 ± 945)

Dimension drawing

●KDZ

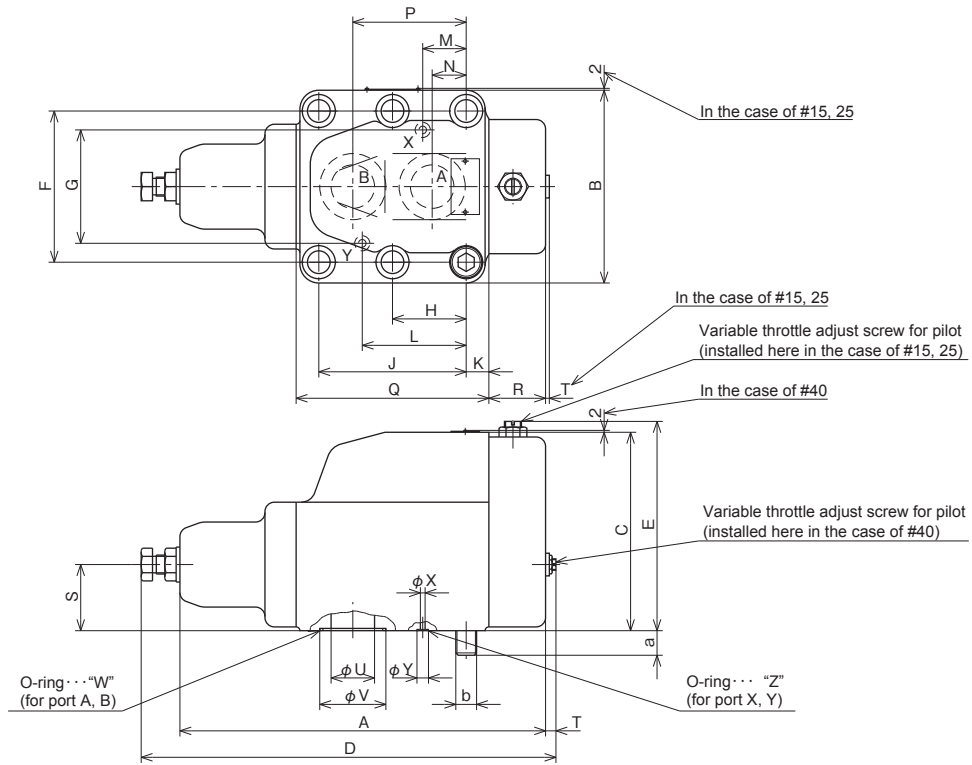

Nominal dimension	A	B	C	D	E	F	G	H	J	K	L	M	N	P	Q	R	S	T	U	V	O-ring dimension "W"	X	Y
15	221	102	104	260	114	80	66	—	60	14	39	21	11	49	88	28	38	0	15	30	2-JIS B2401 G25 Hs90	6	12
25	273	120	128	312	141	97	90	42	84	13	60	24	17	67	110	40	43	4	22	35	2-JIS B2401 G30 Hs90	6	12
40	387	204	210	450	—	160	120	78	156	24	120	36	36	120	204	60	70	12	46	70	2-JIS B2401 G65 Hs90	8	16
Nominal dimension	O-ring dimension "Z"		a	b																			
15	2-JIS B2401 P9 Hs90		16	4-M10																			
25	2-JIS B2401 P9 Hs90		12	6-M10																			
40	2-JIS B2401 P12 Hs90		26	6-M22																			

Flow control valve

	Page
Variable throttle valve ······ T1M ······	3-2
Throttle valve (1) ······ T ······	3-4
Throttle valve (2) ······ T1M ······	3-6
Throttle valve – Cartridge type ······ F1M ······	3-8
Slow return check valve (1) ······ TC ······	3-10
Slow return check valve (2) ······ TC1M ······	3-12
Slow return check valve – Cartridge type ······ FC1M ······	3-14
Slow return check valve – Gasket type ······ KMK ······	3-16
Precision throttle valve ······ F ······	3-18
Temperature and pressure compensated	
flow regulating valve (1) ··· FJC5 to 16 ······	3-22
Temperature and pressure compensated	
flow regulating valve (2) ······ FJC30 ······	3-25
Three-way flow regulating valve ······ FK ······	3-27

In the type selection, we recommend the one indicated in color letters in the type indication explanation.

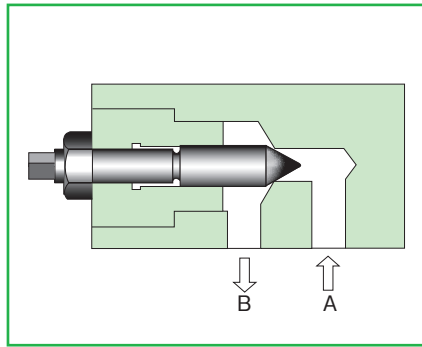

Overview

This variable throttle valve is of needle valve type and can regulate the flow rate steplessly by changing the throttle opening.

Features

1. As this is a needle valve, fine adjustments can be made.
2. As there is no leakage at all when it is fully closed, it can be used as a stop valve.
3. The throttle opening can be adjusted even during operation by turning the adjust thread.
4. As a lock nut is installed, there is no change in the throttle opening by vibration of the pipe during operation.

Type indication

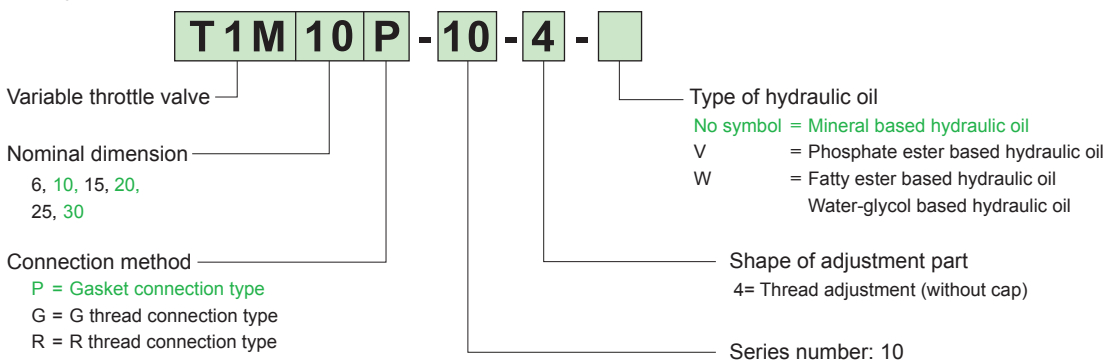

Hydraulic symbols

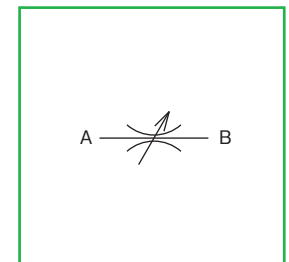

Specifications

Nominal dimension		6	10	15	20	25	30
Maximum working pressure MPa (kgf/cm ²)		30.9 (315)					
Maximum flow rate L/min		20	40	80	150	200	300
Mass kg	Gasket connection type	—	1.5	—	3	—	7
	Thread connection type	1	1	3	3	6.5	6.5

Accessories

Mounting bolt

Type	Hexagon socket head cap thread	Quantity	Tightening torque N·m (kgf·cm)
T1M10P	M8 ×50L	4 pcs.	29.4±4.4 (300±45)
T1M20P	M10×70L	4 pcs.	56.8±8.5 (580±87)
T1M30P	M16×90L	4 pcs.	235.2±35.2 (2400±360)

Pressure drop characteristics (viscosity 37 mm²/s (cSt))

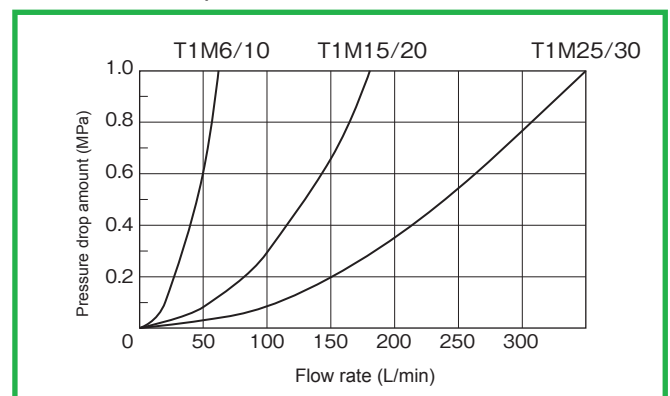

Dimension drawing

T1M*P

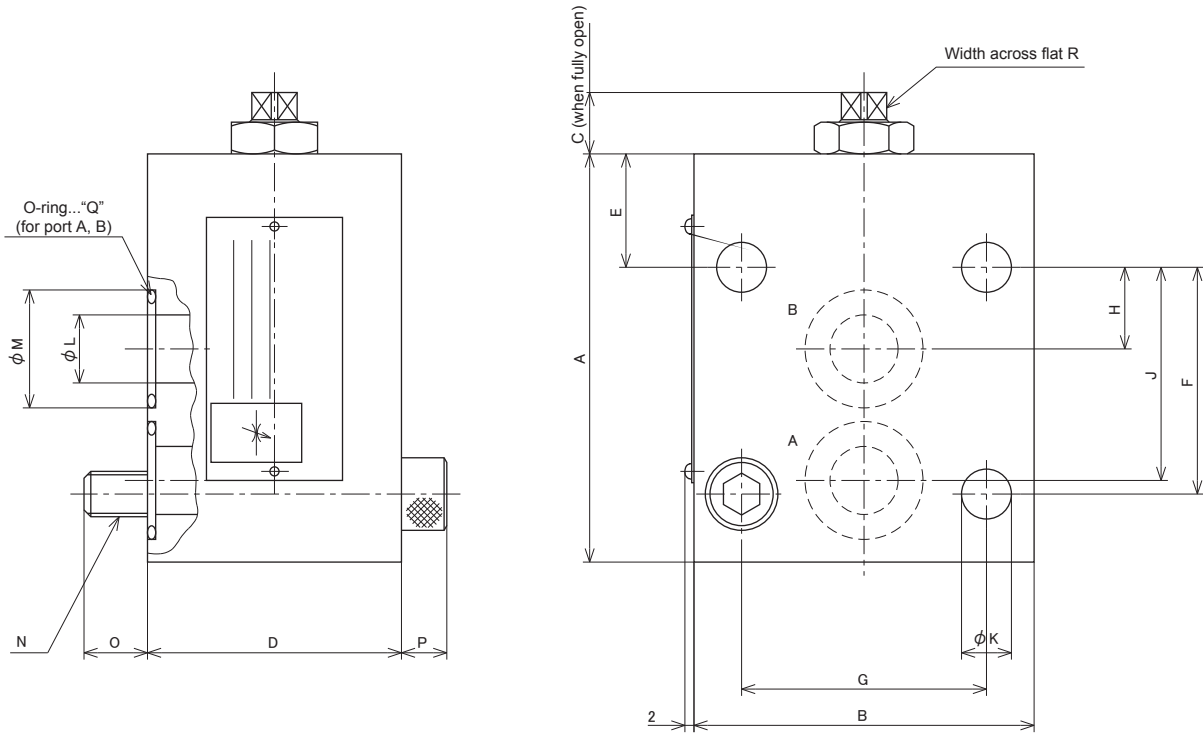

Nominal dimension	A	B	C	D	E	F	G	H	J	ϕK	ϕL	ϕM	N	O	P	O-ring dimension "Q"	R
10	75	65	26	40	30	30	45	7	27	9	8	16	4-M8	10	8	2-JISB2401 P12 Hs90	4
20	90	75	30	56	25	50	54	18	47	11	15	26	4-M10	14	10	2-JISB2401 P22 Hs90	8
30	125	110	32	70	35	75	80	20	65	18	25	40	4-M16	20	16	2-JISB2401 P35 Hs90	10

T1M*G/R

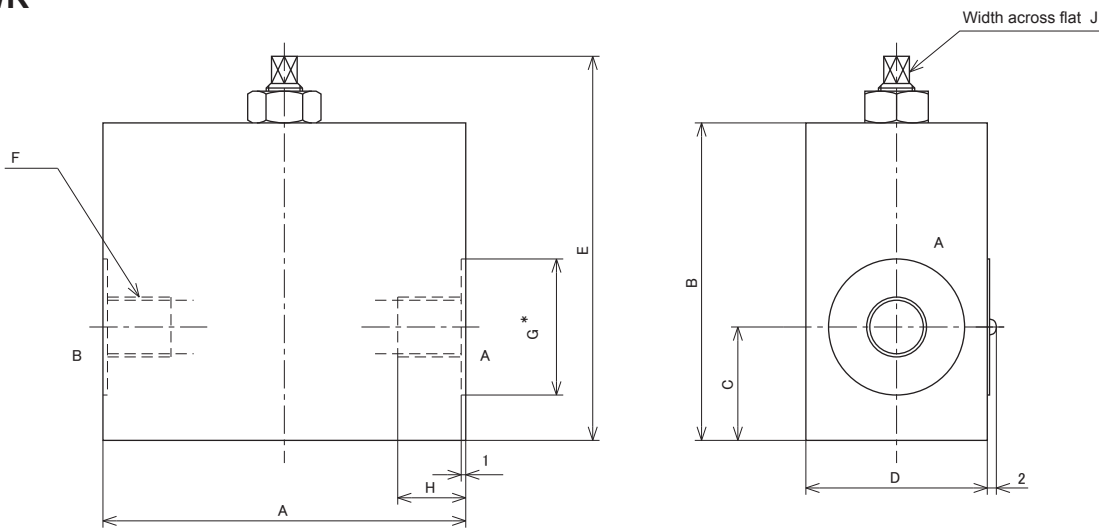

Nominal dimension		A	B	C	D	E	F	G*	H	J
6	G	80	70	25	40	85 to 95	G $\frac{1}{4}$	30	15	4
	R						Rc $\frac{1}{4}$	—	15	4
10	G	80	70	25	40	85 to 95	G $\frac{1}{2}$	42	16	4
	R						Rc $\frac{1}{2}$	—	16	4
15	G	100	85	30	56	100 to 115	G $\frac{3}{4}$	50	18	8
	R						Rc $\frac{3}{4}$	—	18	8
20	G	100	85	30	56	100 to 115	G1	60	20	8
	R						Rc1	—	20	8
25	G	140	115	44	70	132 to 147	G1 $\frac{1}{4}$	76	24	10
	R						Rc1 $\frac{1}{4}$	—	24	10
30	G	140	115	44	70	132 to 147	G1 $\frac{1}{2}$	76	24	10
	R						Rc1 $\frac{1}{2}$	—	24	10

* If F is a Rc screw, there is no counter bore G.

Throttle valve (1)

T

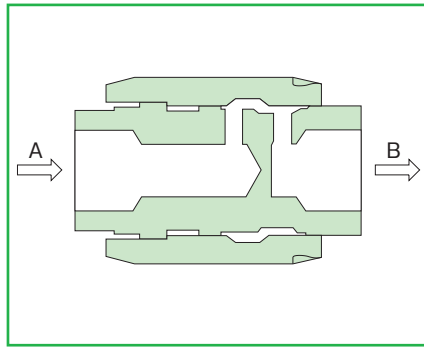
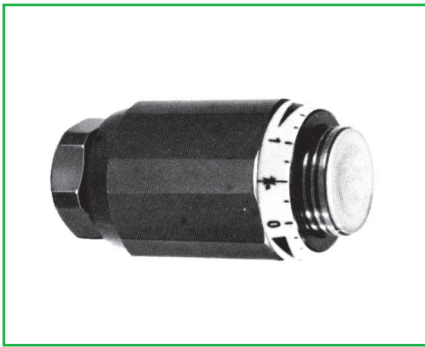

Overview

This variable throttle valve can regulate the flow rate steplessly by changing the throttle opening.

Features

1. Thanks to the adoption of special notches, it is superior in controllability when the opening is small.
2. As this has opening indication scales, it is superior in reproducibility.
3. As this is of in-line type by the thread connection method, it can be installed easily.

Type indication

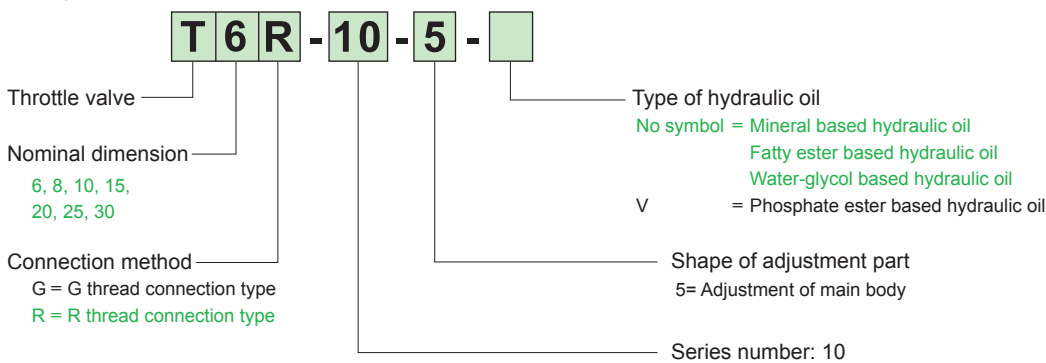

Specifications

Nominal dimension	6	8	10	15	20	25	30
Maximum working pressure MPa (kgf/cm ²)	30.9 (315)						
Maximum flow rate L/min	15	30	50	120	200	300	400
Mass kg	0.3	0.4	0.5	0.7	1.2	2.2	3

Hydraulic symbols

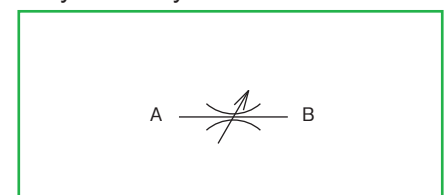

Pressure drop characteristics (viscosity 36 mm²/s (cSt))

● When the throttle valve is fully open

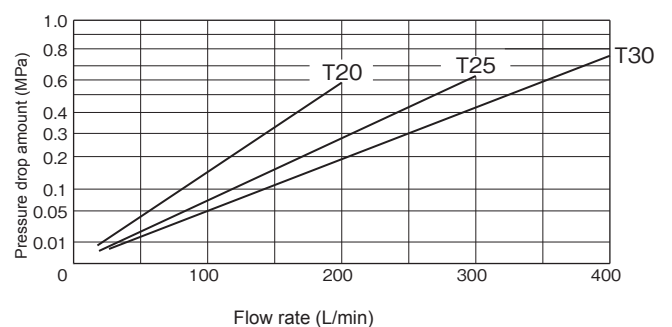
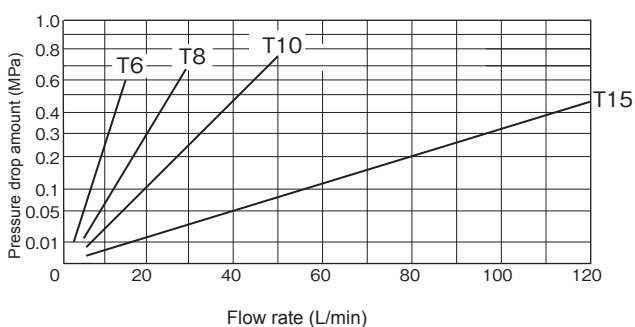

Pressure - Flow rate characteristics (viscosity 36 mm²/s (cSt))

T6

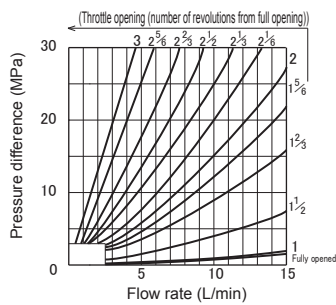

T8

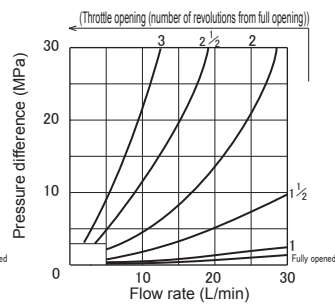

T10

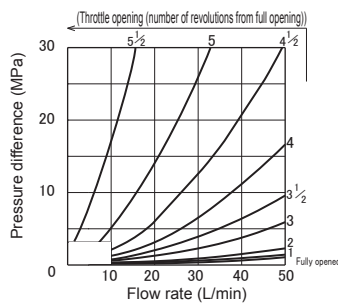

T15

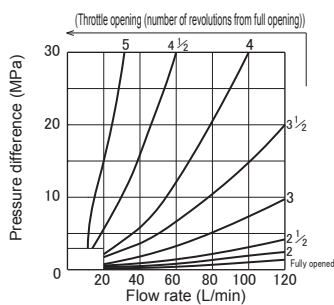

T20

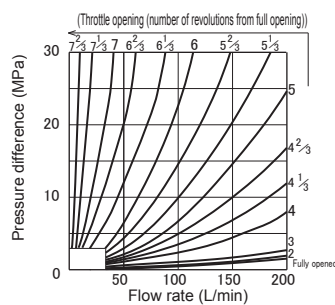

T25

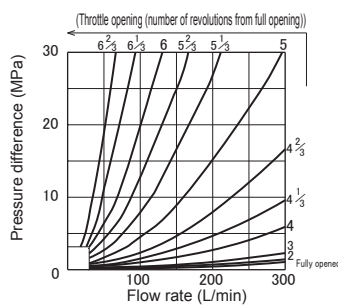

T30

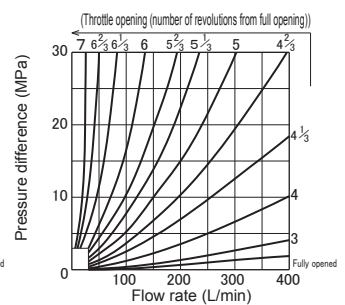

(Note) Throttle opening has an error of approx. one turn by accumulation of dimensional tolerance.

Dimension drawing

T

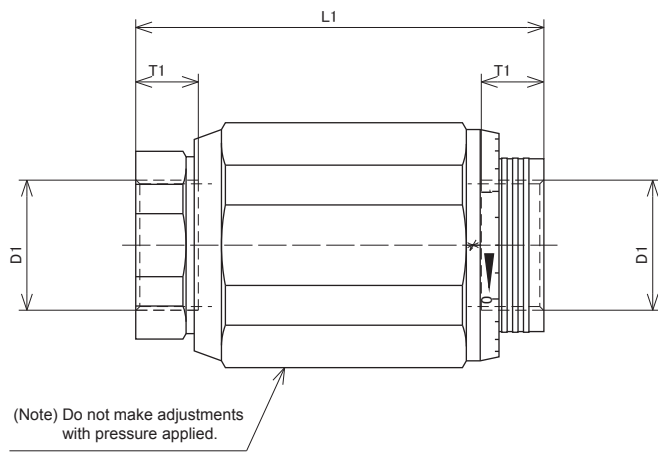
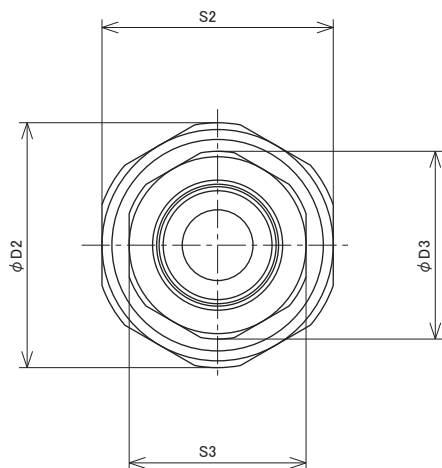

(Note) Do not make adjustments with pressure applied.

Nominal dimension		D1	D2	D3	S2	S3	L1	T1
6	G	G 1/4	44	29.5	41	27	65	12
	R	R 1/4						9
8	G	G 3/8	49.5	33	46	30	65	12
	R	R 3/8						10
10	G	G 1/2	58	42.5	55	41	80	14
	R	R 1/2						12
15	G	G 3/4	66	49.5	60	46	100	16
	R	R 3/4						14
20	G	G1	78	52.5	70	50	110	18
	R	R1						16
25	G	G1 1/4	90	62.5	85	60	130	23
	R	R1 1/4						18
30	G	G1 1/2	90	69	85	65	150	23
	R	R1 1/2						18

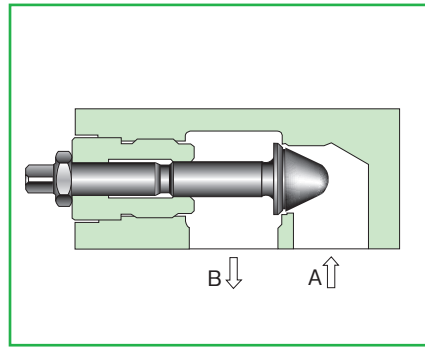
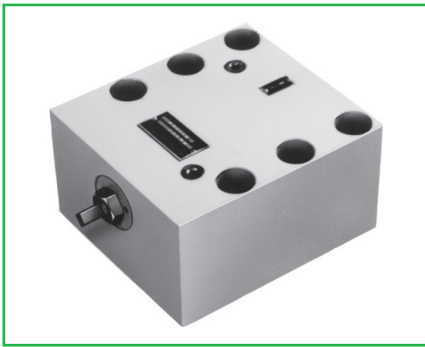

Overview

This variable throttle valve is of needle valve type and can regulate the flow rate steplessly by changing the throttle opening.

Features

- As this is a needle valve, fine adjustments can be made.
- As there is no leakage at all when it is fully closed, it can be used as a stop valve.
- The throttle opening can be adjusted even during operation by turning the adjust thread.
- As a lock nut is installed, there is no change in the throttle opening by vibration of the pipe during operation.

Hydraulic symbols

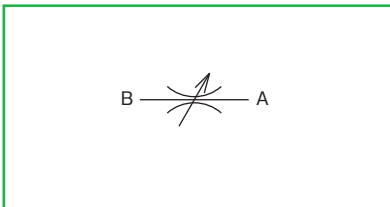

Type indication

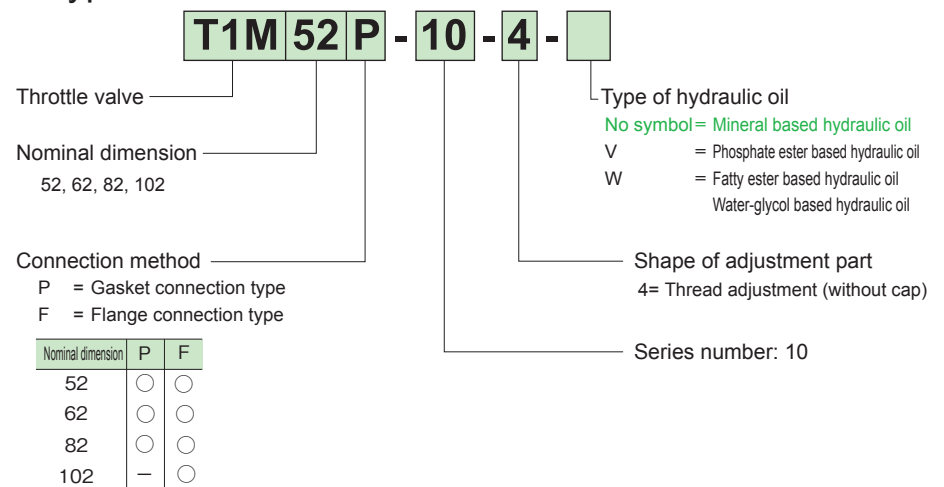

Specifications

Nominal dimension		52	62	82	102
Maximum working pressure MPa (kgf/cm ²)		30.9(315)			
Maximum flow rate L/min		700	1100	1800	3000
Mass kg	Gasket connection type	15	27	53	—
	Flange connection type	14	23	45	86

Flange

Valve type	Flange type	Connection diameter	Mass
T1M52F	TFAA-40	2B	2.6kg
	TFXA-40	2B	2.7kg
T1M62F	TFAA-50	2½B	3.9kg
	TFXA-50	2½B	4.5kg
T1M82F	TFAA-63	3B	7.9kg
	TFXA-63	3B	8.5kg
T1M102F	TFAA-80	4B	13kg
	TFXA-80	4B	14kg

When you use a flange, please place an order for the left flange type. For the dimension drawing, refer to page 16 of the appendix.

Accessories

Mounting bolt

Type	Hexagon socket head cap thread	Quantity	Tightening torque N·m (kgf·cm)
T1M52P	M16×95L	6 pcs.	235.2±35.2 (2400±360)
T1M62P	M20×115L	6 pcs.	431.2±64.6 (4400±660)
T1M82P	M20×145L	6 pcs.	

Pressure drop characteristics (viscosity 36 mm²/s (cSt))

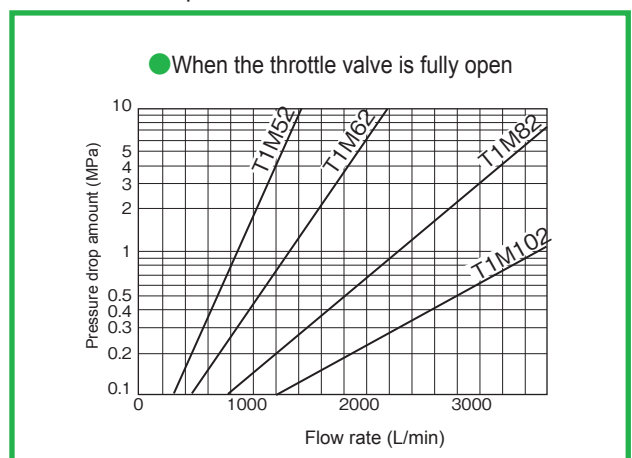

Dimension drawing

T1M*P

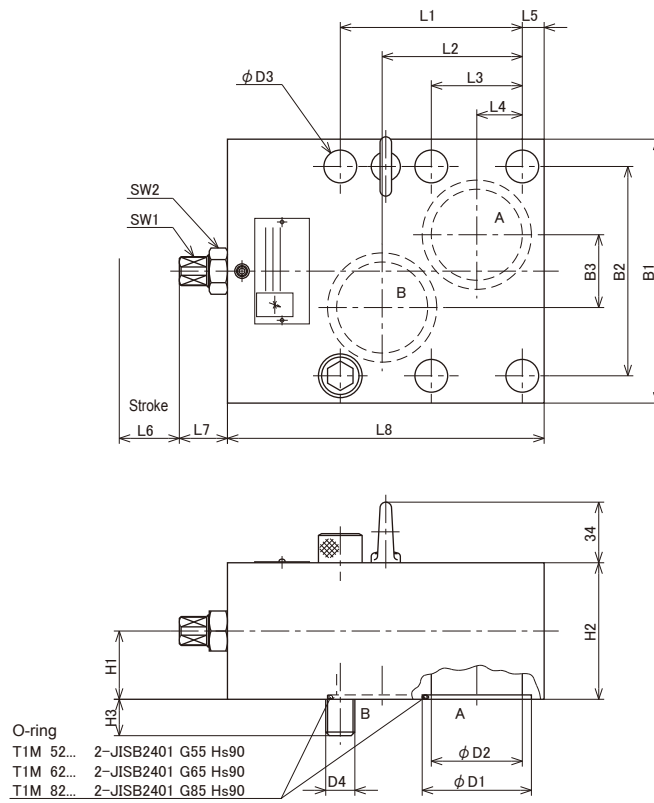

Nominal dimension	B1	B2	B3	D1	D2	D3	D4	H1	H2	H3	L1	L2	L3	L4	L5	L6	L7	L8	SW1	SW2
52	145	115	40	60	50	18	6-M16	37.5	75	20	100	77	50	25	12	33	26	174	14	22
62	180	140	40	70	60	22	6-M20	45	90	25	128	100	65	34	17.5	45	28	220	17	27
82	210	170	50	90	80	22	6-M20	60	120	25	140	115	70	30	35	57	27	274	17	30

T1M*F

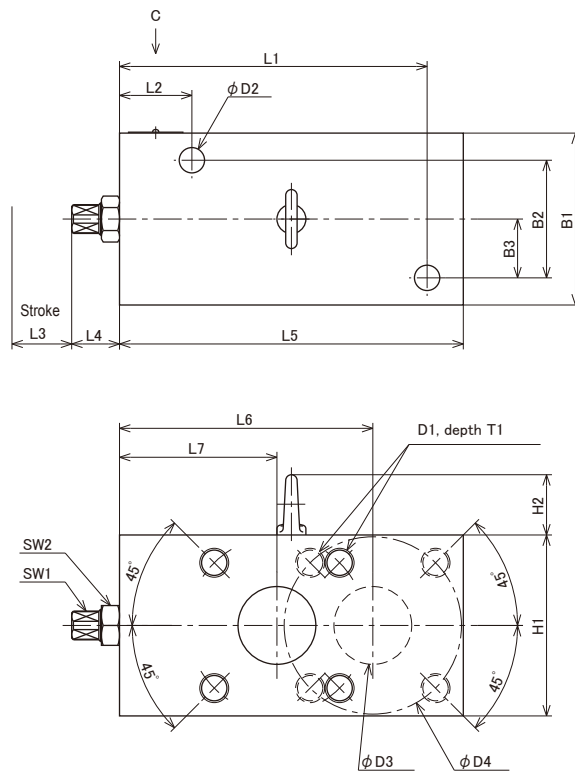

Nominal dimension	B1	B2	B3	D1	D2	D3	D4	H1	H2	L1	L2	L3	L4	L5	L6	L7	T1	SW1	SW2
52	95	65	32.5	4-M16	14	45	98	100	34	170	40	26	21	190	140	87	26	14	22
62	110	75	37.5	4-M20	14	53	118	120	34	205	45	29	27	230	170	106	32	17	27
82	140	95	47.5	4-M24	14	72	145	150	34	230	50	36	26	285	210	127	36	17	30
102	175	130	65	4-M30	22	90	175	180	42	310	70	44	33	360	270	162	40	27	41

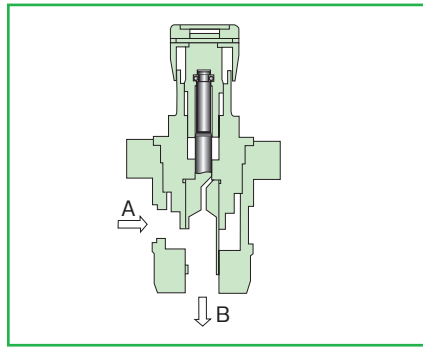

Overview

This variable throttle valve can regulate the flow rate steplessly by changing the throttle opening.

Features

1. As this is a cartridge type, it can be incorporated in a manifold in a compact way.
2. As this has opening indication scales, it is superior in reproducibility.
3. This is superior in controllability when the opening is small.

Type indication

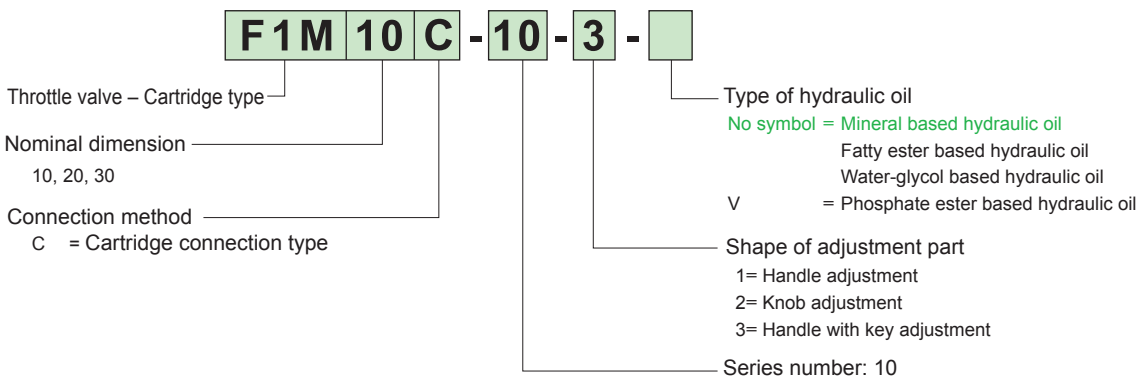

Hydraulic symbols

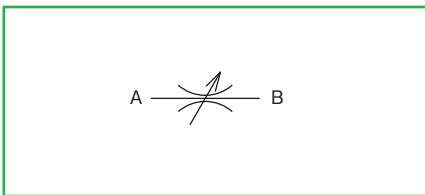

Specifications

Nominal dimension	10	20	30
Maximum working pressure MPa (kgf/cm ²)	30.9(315)		
Maximum flow rate L/min	100	200	400
Mass kg	0.9	1.8	3.8

Accessories

Mounting bolt

Type	Hexagon socket head cap thread	Quantity	Tightening torque N·m (kgf·cm)
F1M10C	M8 ×16L	4 pcs.	29.4±4.4 (300±45)
F1M20C	M12×25L	4 pcs.	98.0±14.7 (1000±150)
F1M30C	M16×30L	4 pcs.	235.2±35.2 (2400±360)

■ Pressure - Flow rate characteristics (viscosity 36 mm²/s (cSt))

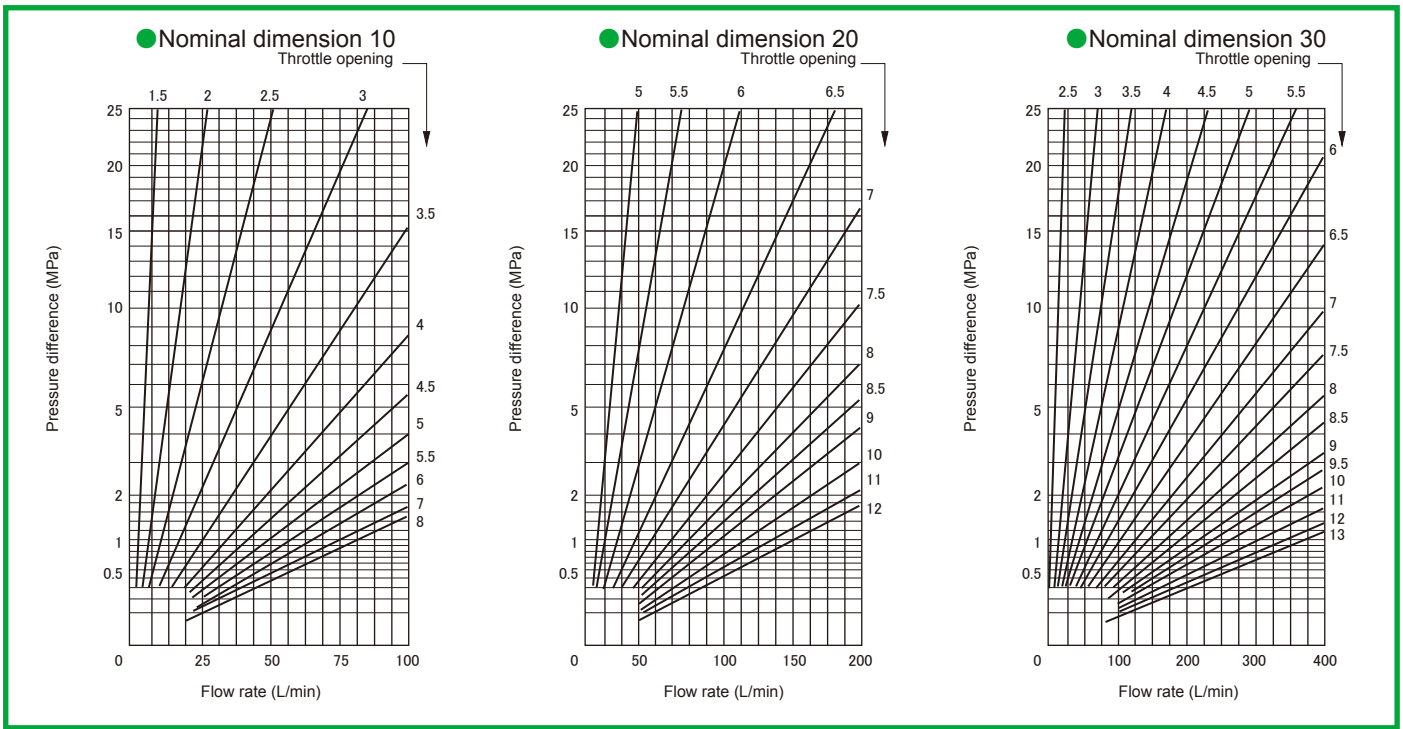

■ Dimension drawing

● Throttle valve - Cartridge type

● Handle adjusting type

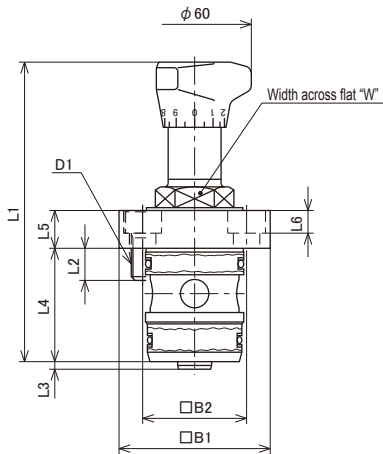

● Knob adjusting type

(The dimension which is not entered is the same as that of the handle adjusting type.)

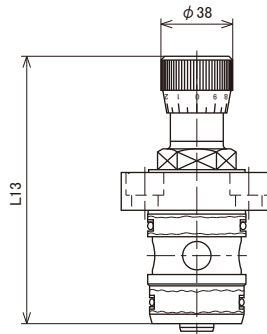

● Handle with key adjusting type

(The dimension which is not entered is the same as that of the handle adjusting type.)

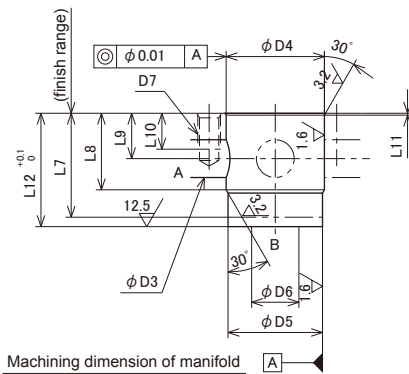
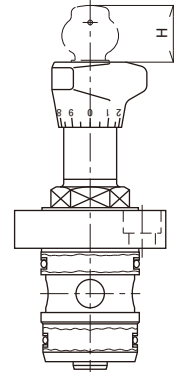

Machining dimension of manifold **A**

Nominal dimension	B1	B2	H	D1	D3	D4 ^{H7}	D5 ^{H7}	D6	D7	L1	L2	L3	L4	L5	L6	L7	L8	L9	L10	L11	L12	L13	W
10	65	48	30	4-M8	15	38	36	15	4-M8	136	10.8	2	46.5	12	6.8	44	34	20.5	15	1.5	47	119	30
20	80	55	30	4-M12	20	52	50	25	4-M12	160	17	2	60	20	12	55	40.5	24	19	1.5	60.5	142	36
30	105	70	30	4-M16	30	72	70	35	4-M16	187	20	5	80	26	16	75	58	35	22	2	80.5	169	55

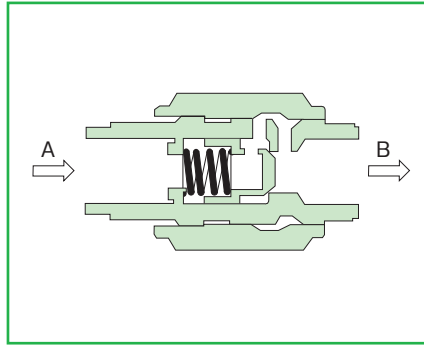

Overview

This slow return check valve, in which a check valve is assembled into the variable throttle valve, can restrict the flow in one direction and allow the flow in the opposite direction to pass freely.

Features

1. Thanks to the adoption of special notches, it is superior in controllability when the opening is small.
2. As this has opening indication scales, it is superior in reproducibility.
3. As this is of in-line type by the thread connection method, it can be assembled easily.

Type indication

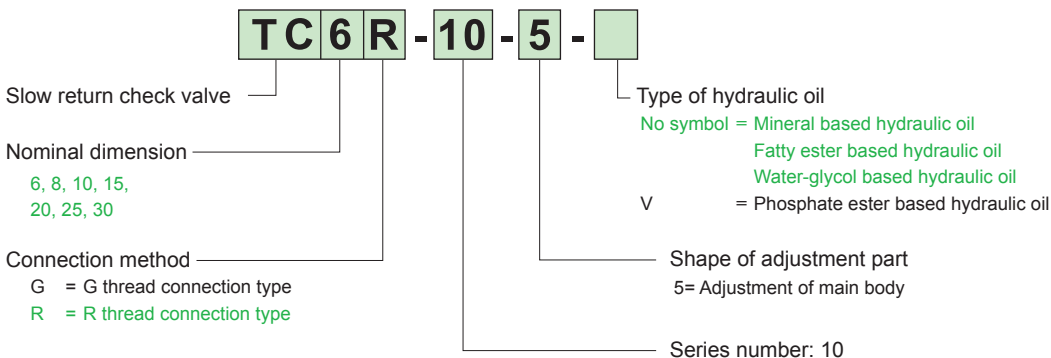

Hydraulic symbols

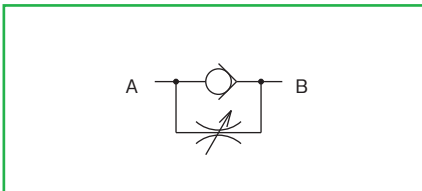

Specifications

Nominal dimension	6	8	10	15	20	25	30
Maximum working pressure MPa (kgf/cm ²)	30.9 (315)						
Maximum flow rate L/min	15	30	50	120	200	300	400
Cracking pressure MPa (kgf/cm ²)	0.05 (0.5)						
Mass kg	0.3	0.4	0.7	1.1	1.9	3.2	4.1

Pressure - Flow rate characteristics

- Similar to those of throttle valve (1). Refer to the section of the type number index "T6 to 30".

Pressure drop characteristics (viscosity 36 mm²/s (cSt))

- When the throttle valve is fully open and the check valve is free flow (B→A)

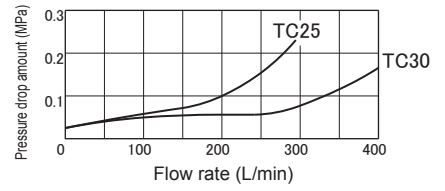
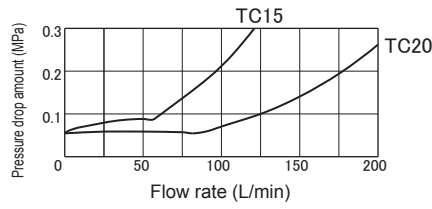
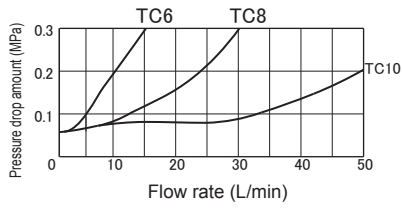

- When the throttle valve is fully open (A→B)

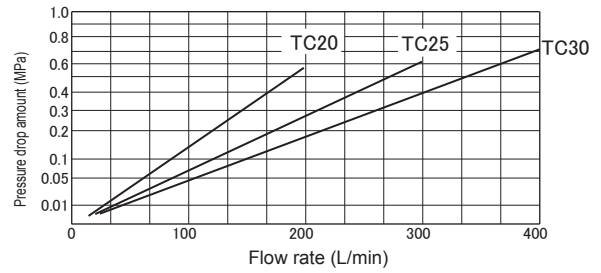
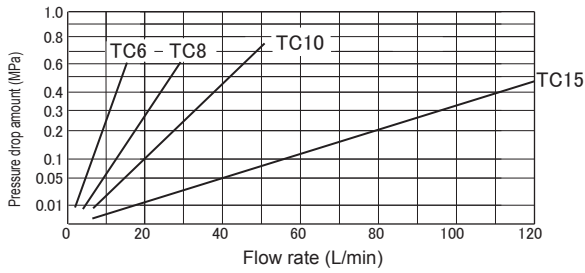

Dimension drawing

TC

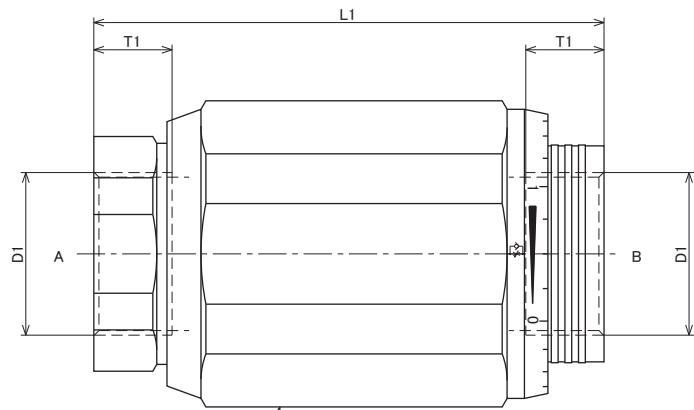
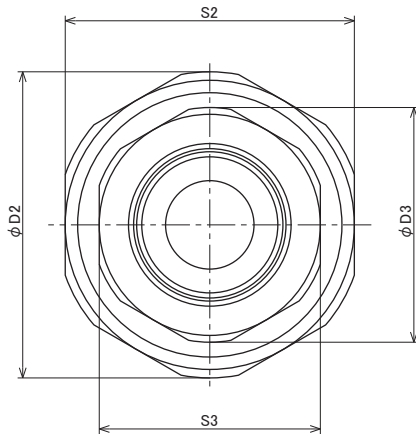

(Note) Do not make adjustments with pressure applied.

Nominal dimension	D1	D2	D3	S2	S3	L1	T1
6	G	G 1/4	44	29.5	41	27	65
	R	R 1/4					9
8	G	G 3/8	49.5	33	46	30	65
	R	R 3/8					10
10	G	G 1/2	58	42.5	55	41	80
	R	R 1/2					12
15	G	G 3/4	66	49.5	60	46	100
	R	R 3/4					14
20	G	G1	78	52.5	70	50	110
	R	R1					16
25	G	G1 1/4	90	62.5	85	60	130
	R	R1 1/4					18
30	G	G1 1/2	90	69	85	65	150
	R	R1 1/2					18

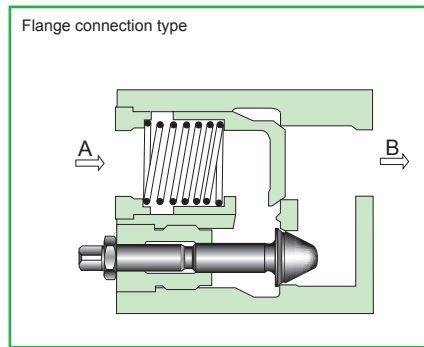

Hydraulic symbols

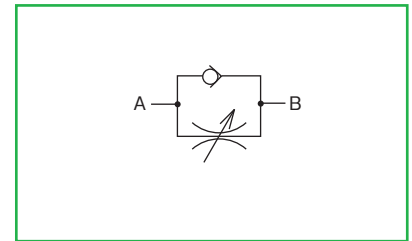

Overview

This slow return check valve, in which a check valve is assembled into the variable throttle valve, can restrict the flow in one direction and allow the flow in the opposite direction to pass freely.

Features

- As this is a needle valve, fine adjustments can be made.
- The throttle opening can be adjusted even during operation by turning the adjust thread.
- As a lock nut is installed, there is no change in the throttle opening by vibration of the pipe during operation.

Specifications

Nominal dimension		52	62	82	102
Maximum working pressure MPa (kgf/cm ²)		30.9 (315)			
Maximum flow rate L/min		700	1100	1800	3000
Cracking pressure MPa (kgf/cm ²)		0.05 (0.5)			
Mass kg	Gasket connection type	32	60	105	—
	Flange connection type	20	35	65	140

Flange

Valve type	Flange type	Connection diameter	Mass
TC1M52F	TFAA-40	2B	2.6kg
	TFXA-40	2B	2.7kg
TC1M62F	TFAA-50	2½B	3.9kg
	TFXA-50	2½B	4.5kg
TC1M82F	TFAA-63	3B	7.9kg
	TFXA-63	3B	8.5kg
TC1M102F	TFAA-80	4B	13kg
	TFXA-80	4B	14kg

When you use a flange, please place an order for the left flange type. For the dimension drawing, refer to page 16 of the appendix.

Accessories

Mounting bolt

Type	Hexagon socket head cap thread	Quantity	Tightening torque N·m (kgf·cm)
TC1M52P	M16×180L	6 pcs.	235.2±35.2 (2400±360)
TC1M62P	M20×215L	6 pcs.	431.2±64.6 (4400±660)
TC1M82P	M20×255L	6 pcs.	

Type indication

TC1M 52 P - 10 - 4 -

- Slow return check valve
- Nominal dimension: 52, 62, 82, 102
- Connection method: P = Gasket connection type, F = Flange connection type
- Type of hydraulic oil: No symbol = Mineral based hydraulic oil, V = Phosphate ester based hydraulic oil, W = Fatty ester based hydraulic oil, Water-glycol based hydraulic oil
- Shape of adjustment part: 4 = Thread adjustment (without cap)
- Series number: 10

Nominal dimension	P	F
52	○	○
62	○	○
82	○	○
102	—	○

Pressure drop characteristics (viscosity 36 mm²/s(cSt))

- When the throttle valve is fully open and the check valve is free flow (B→A)

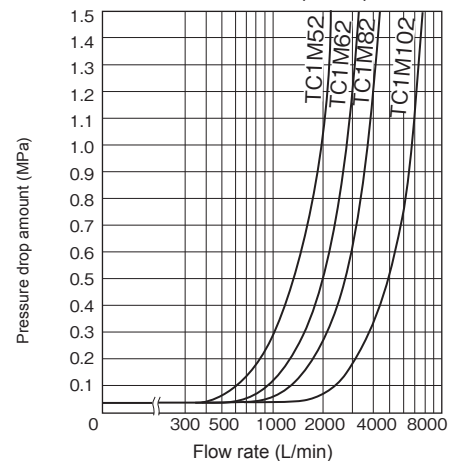

- When the throttle valve is fully open (A→B)

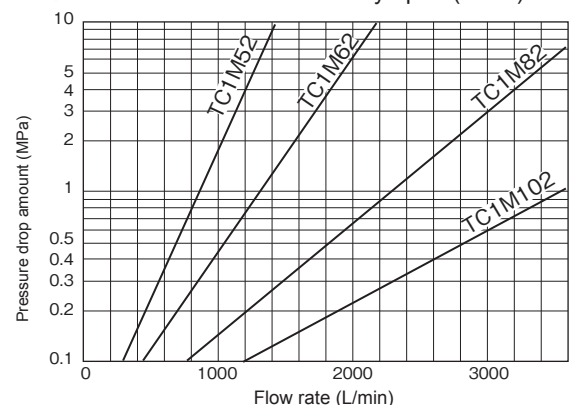

Dimension drawing

● TC1M*P

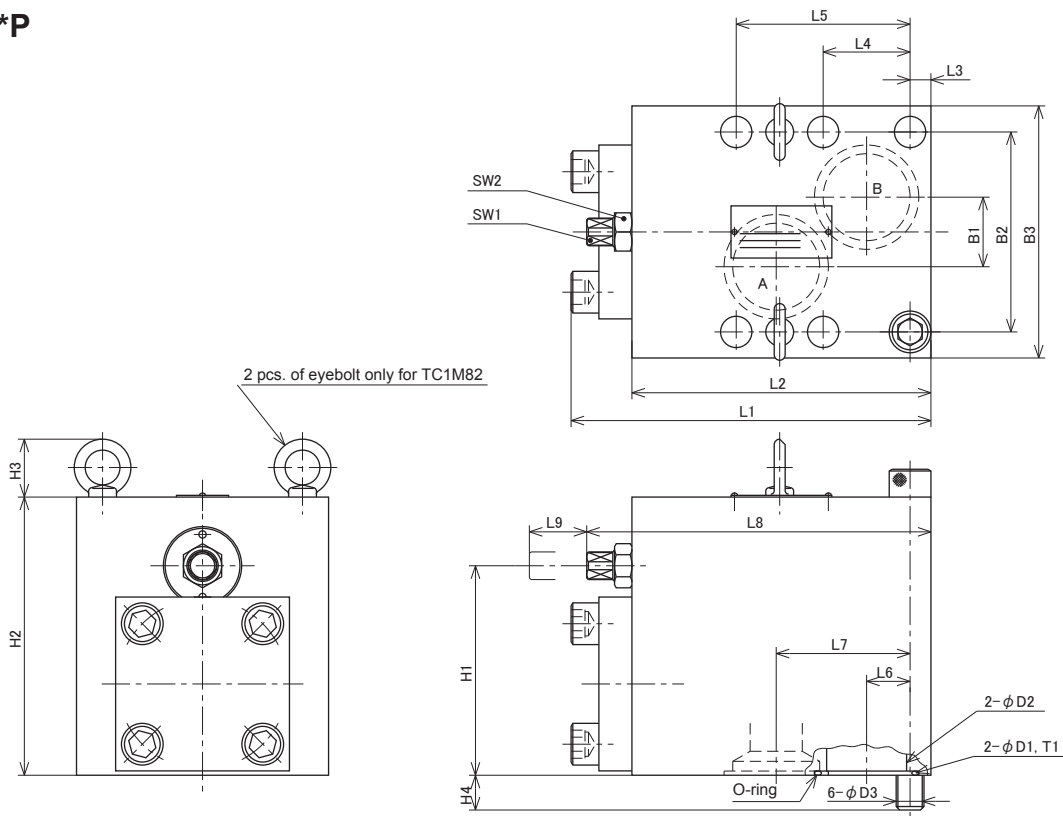

Nominal dimension	B1	B2	B3	D1	D2	D3	H1	H2	H3	H4	L1	L2	L3	L4	L5	L6	L7	L8	L9	T1	SW1	SW2	O-ring dimension
52	40	115	145	60	50	M16	120.5	160	34	20	207	172	12	50	100	25	77	198	33	2.4	14	22	2-JISB2401 G55 Hs90
62	40	140	180	70	60	M20	142	190	42	25	262.5	220	17.5	65	128	34	100	248	45	2.4	17	27	2-JISB2401 G65 Hs90
82	50	170	210	90	80	M20	172	230	42	25	325	275	35	70	140	30	115	302	57	2.4	17	30	2-JISB2401 G85 Hs90

● TC1M*F

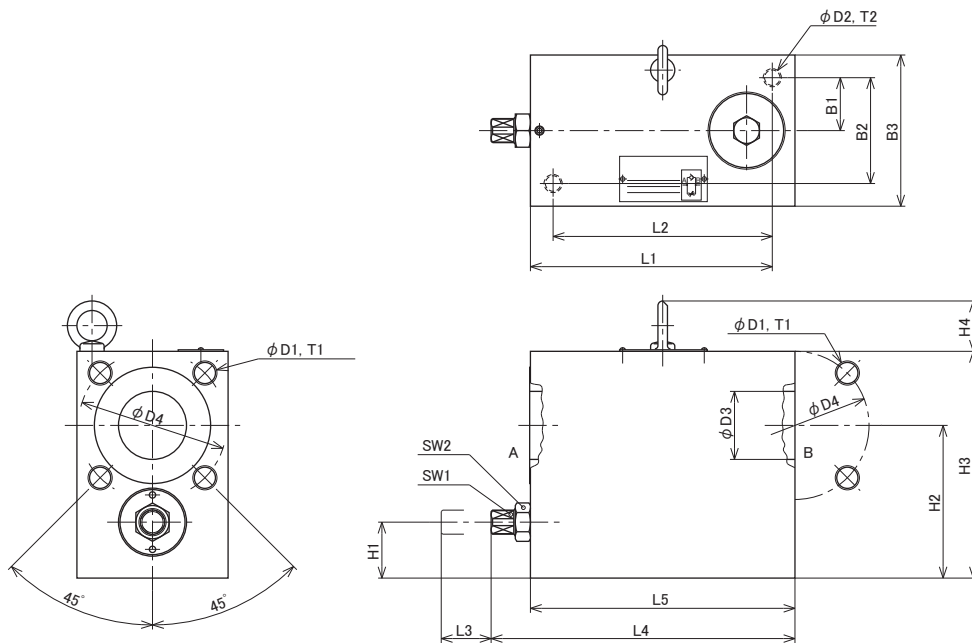

Nominal dimension	B1	B2	B3	D1	D2	D3	D4	H1	H2	H3	H4	L1	L2	L3	L4	L5	T1	T2	SW1	SW2
52	35	70	100	4-M16	2-M12	45	98	37	101	150	34	160	145	33	201	175	26	20	14	22
62	45	90	120	4-M20	2-M12	53	118	44	121	180	34	195	180	45	238	210	32	20	17	27
82	55	110	150	4-M24	2-M12	72	145	52	146	220	42	240	220	57	287	260	36	20	17	30
102	70	140	180	4-M30	2-M16	90	175	70	186	275	51	320	270	70	408	370	40	30	27	41

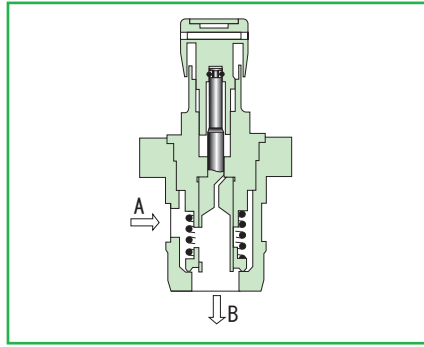

Overview

This slow return check valve, in which a check valve is assembled into the variable throttle valve, can restrict the flow in one direction and allow the flow in the opposite direction to pass freely.

Features

1. As this is a cartridge type, it can be incorporated in a manifold in a compact way.
2. As this has opening indication scales, it is superior in reproducibility.
3. This is superior in controllability when the opening is small.

Type indication

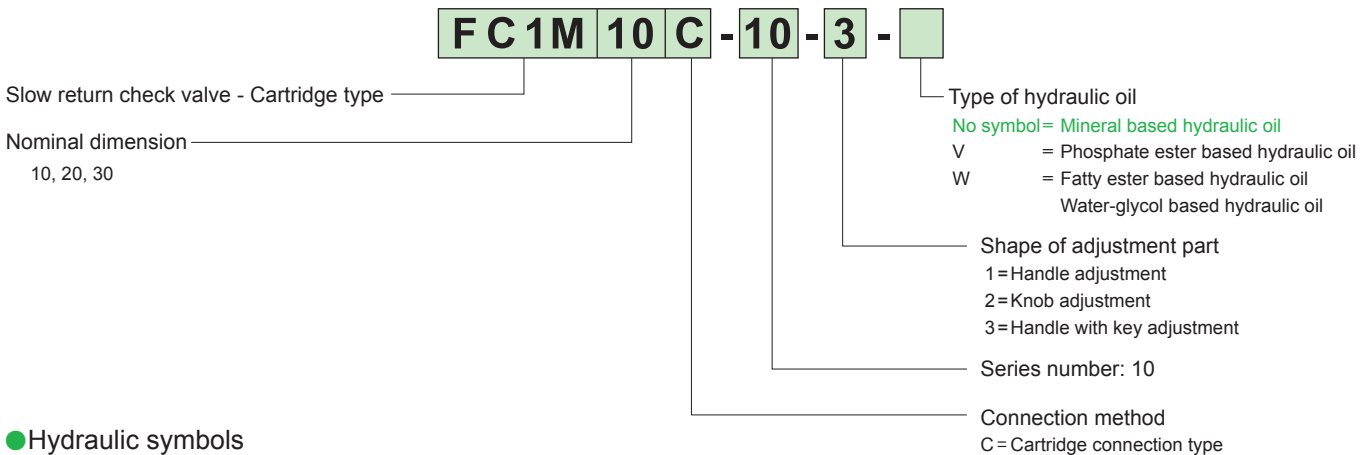

Hydraulic symbols

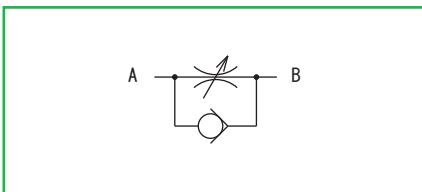

Specifications

Nominal dimension	10	20	30
Maximum working pressure MPa (kgf/cm ²)	30.9 (315)		
Maximum flow rate L/min	100	200	400
Cracking pressure MPa (kgf/cm ²)	0.1 (1.0)		
Mass kg	0.9	1.8	3.8

Pressure - Flow rate characteristics (viscosity 36 mm²/s (cSt))

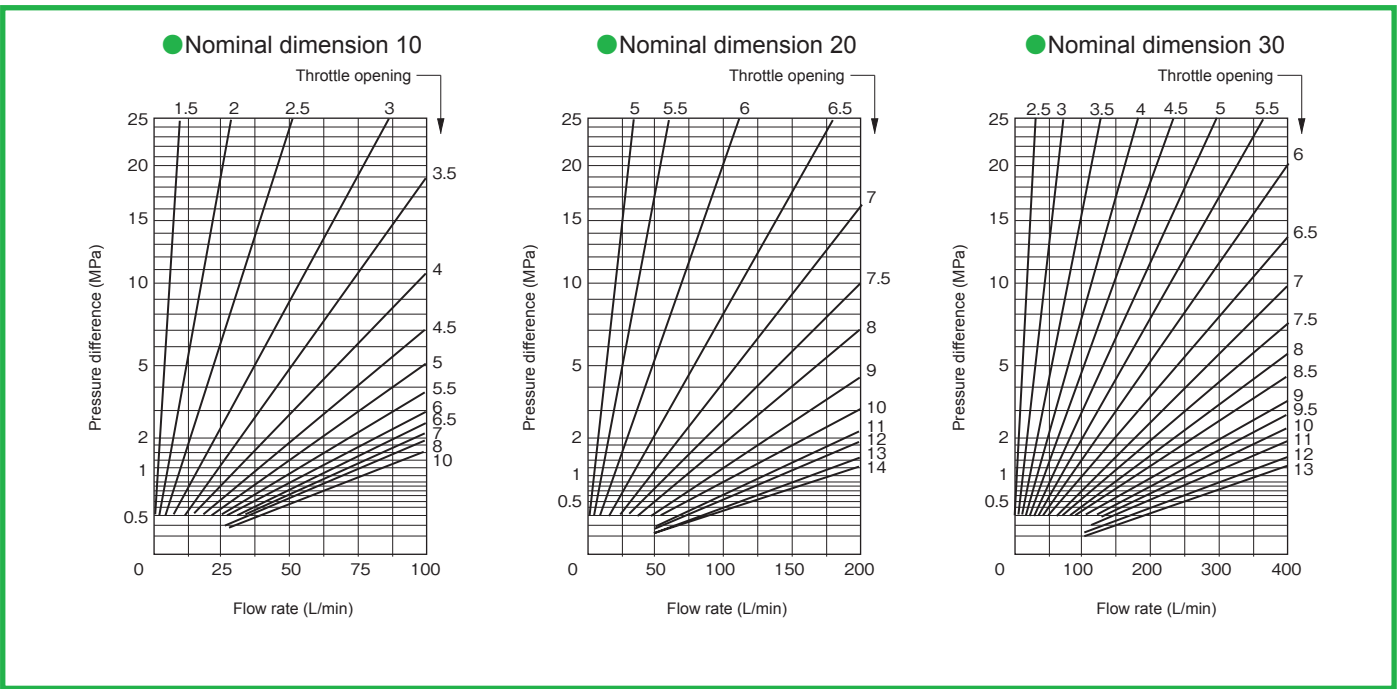

Pressure drop characteristics (viscosity 36 mm²/s (cSt))

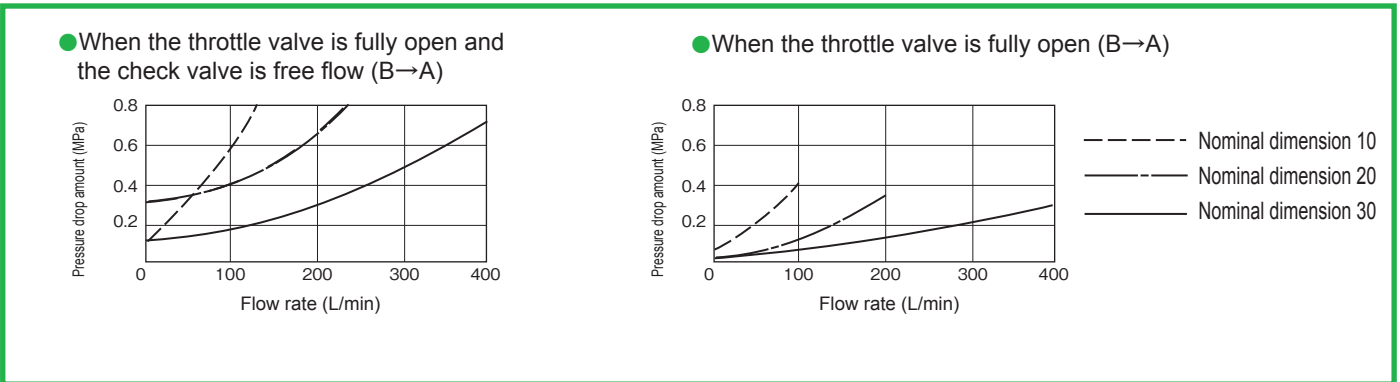

Dimension drawing

- The outside dimension is same as that of the throttle valve - cartridge type. Refer to the section of the type number index "F1M10, 20, 30".

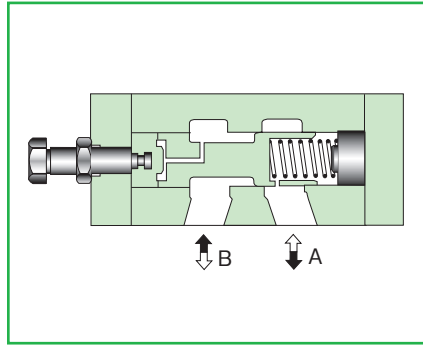
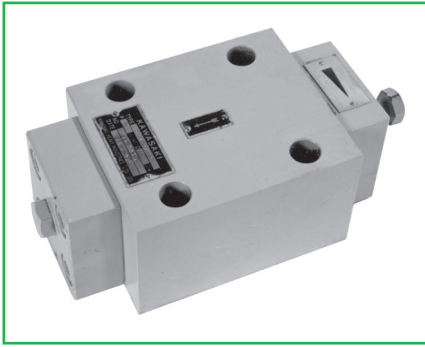

Overview

This slow return check valve, in which a check valve is assembled into the variable throttle valve, can restrict the flow in one direction and allow the flow in the opposite direction to pass freely.

Features

1. This is of gasket connection type.
2. As a lock nut is installed, there is no change in the throttle opening by vibration of the pipe during operation.
3. The number of parts is small and the structure is simple.
4. As there is no seat part, it is superior in durability.

Type indication

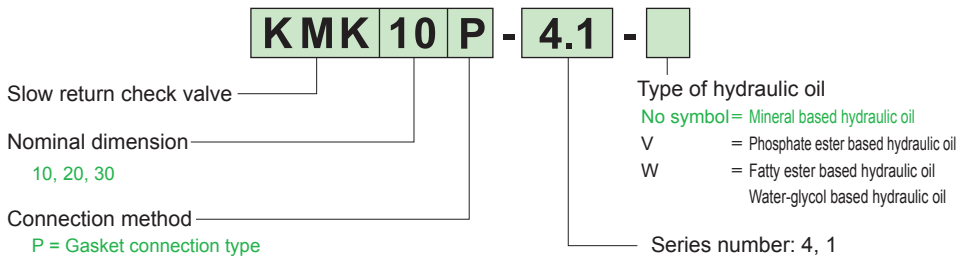

Hydraulic symbols

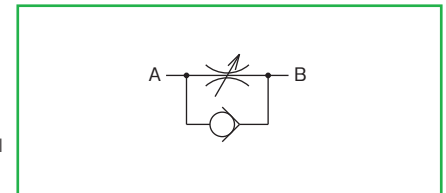

Precautions in use

- Make adjustments with no pressure applied. Be careful that if the adjust thread is loosened excessively by a spanner, etc., the valve may be broken.

Specifications

Nominal dimension	10	20	30
Maximum working pressure MPa (kgf/cm ²)	30.9 (315)		
Maximum flow rate L/min	100	200	300
Cracking pressure MPa (ikgf/cm ²)	0.05 (0.5)		
Mass kg	4.3	9.0	22

Pressure - Flow rate characteristics (viscosity 36 mm²/s (cSt))

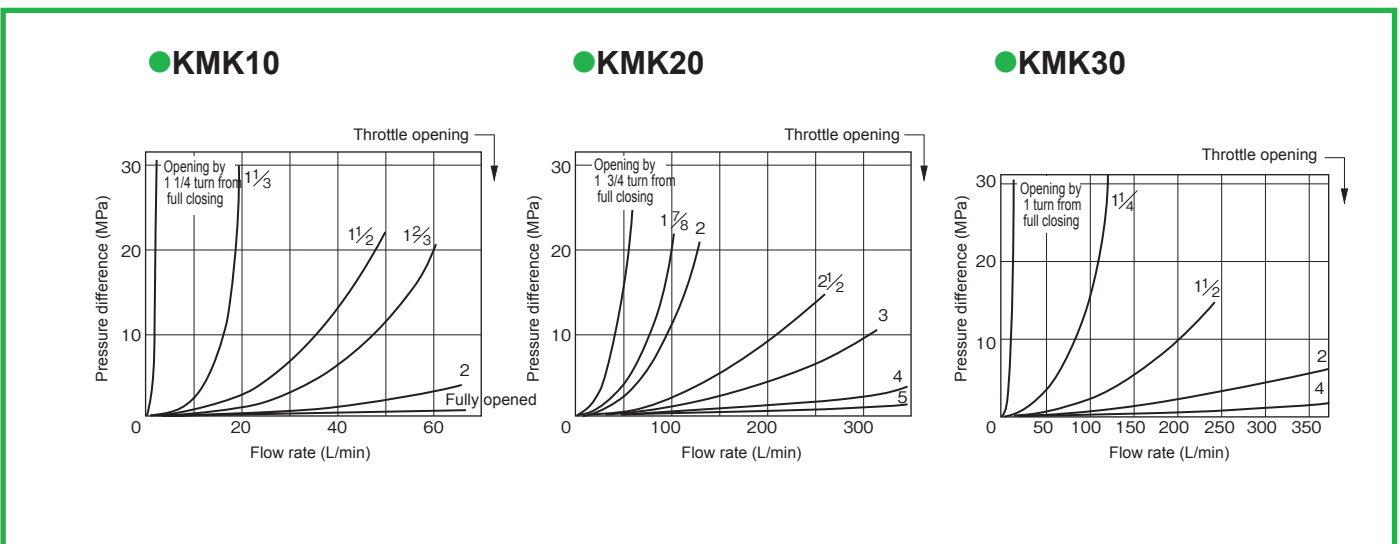

Pressure drop characteristics (viscosity 36 mm²/s (cSt))

- When the throttle valve is fully open and the check valve is free flow (B→A)

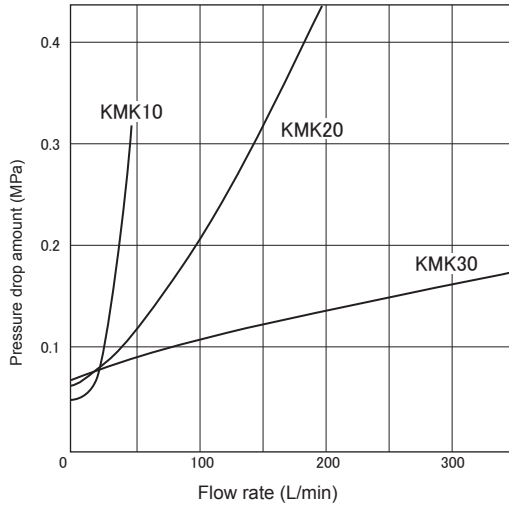

Accessories

- Mounting bolt

Type	Hexagon socket head cap thread	Quantity	Tightening torque N·m (kgf·cm)
KMK10P	M10 × 65L	4 pcs.	56.8 ± 8.5 (580 ± 87)
KMK20P	M14 × 90L	4 pcs.	156.8 ± 23.5 (1600 ± 240)
KMK30P	M16 × 120L	6 pcs.	235.2 ± 35.2 (2400 ± 360)

Dimension drawing

- KMK

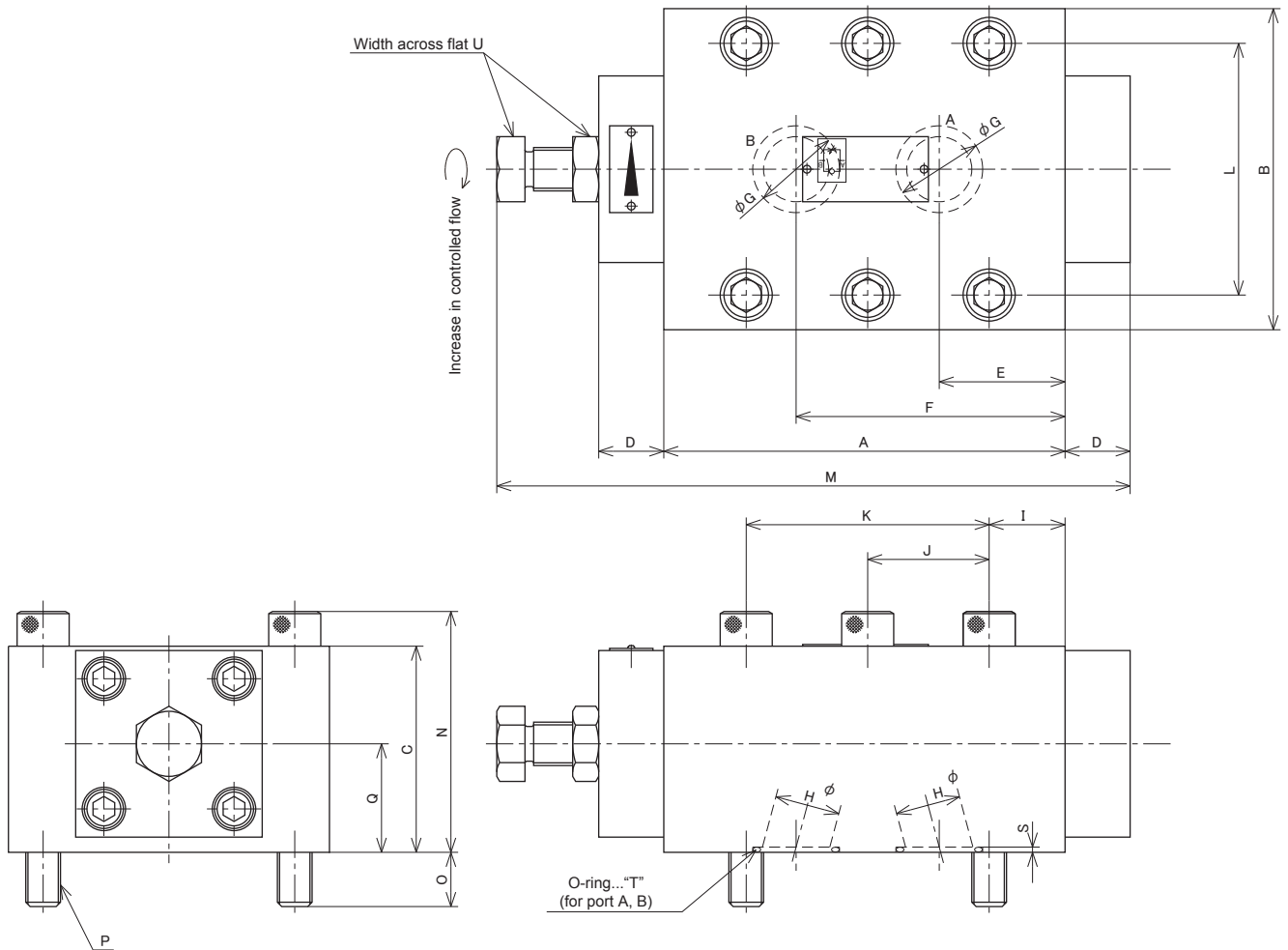

Nominal dimension	A	B	C	D	E	F	G	H	I	J	K	L	M	N	O	P	Q	S	O-ring dimension "T"	U
10	110	84	50	22	39	69	22	11	29	—	40	64	184	60	15	4-M10	25	1.8	2-JIS B2401 P18 Hs90	17
20	140	103	70	28	46	94	30	18	34	—	72	76	226	84	20	4-M14	35	2.5	2-JIS B2401 G25 Hs90	19
30	185	148	95	30	58	124	40	30	35	56	112	116	295	111	25	6-M16	50	2.5	2-JIS B2401 G35 Hs90	30

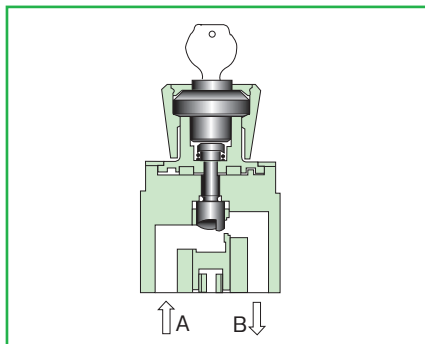

Overview

This precision throttle valve can regulate the flow rate steplessly by changing the throttle opening.

Features

- As the restriction part is of sharp-edged orifice structure, the valve is less likely to be sensitive to the effect of viscosity change of oil and high-precision temperature compensation can be obtained.
- Valves of the cartridge type, gasket connection type and thread connection type are available.

Type indication

F5C-10-3/3Q-

- F**: Precision throttle valve
- 5**: Nominal dimension 5, 10
- C**: Connection method
 - P = Gasket connection type
 - G = G thread connection type
 - R = R thread connection type
 - C = Cartridge type
- 10**: Series number: 10
- 3**: Shape of adjustment part
 - 3 = Handle with key adjustment
- 3Q**: Throttle pin symbol
 - No symbol = Mineral based hydraulic oil
 - V = Phosphate ester based hydraulic oil
 - W = Fatty ester based hydraulic oil
 - Water-glycol based hydraulic oil

Hydraulic symbols

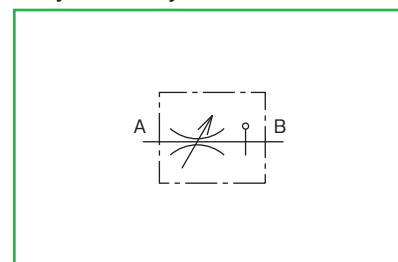

Specifications

Nominal dimension		5	10
Maximum working pressure MPa (kgf/cm ²)		20.6 (210)	
Maximum flow rate L/min		10	50
Mass kg	Gasket connection type	1.4	
	Thread connection type	1.6	
	Cartridge type	1.0	

Option

A precision throttle valve with a check valve is also available. Please contact us for the details. (nominal dimension 5 only)

Hydraulic symbols

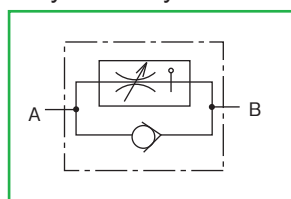

Type indication

FC5P-10

Sub-plate

Valve type	Sub-plate type	Connection diameter	Mass
F5P	FJC5R14-0	Rc $\frac{1}{4}$	1kg
	FJC5G14-0	G $\frac{1}{4}$	
F10P	P-F10R12-0	Rc $\frac{1}{2}$	1.2kg
	P-F10G12-0	G $\frac{1}{2}$	

When you use a sub-plate, please place an order for the following sub-plate type. For the dimension drawing, refer to page 8 of the appendix.

Accessories

Mounting bolt

Type	Hexagon socket head cap thread	Quantity	Tightening torque N·m (kgf·cm)
F5P	M5×50L	4 pcs.	6.9±1.0 (70±10)
F10P			

Pressure - Flow rate characteristics (viscosity 36 mm²/s (cSt))

F5

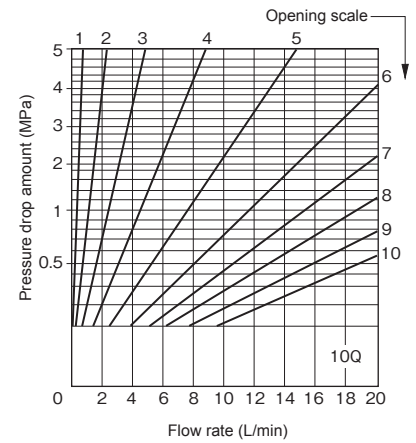
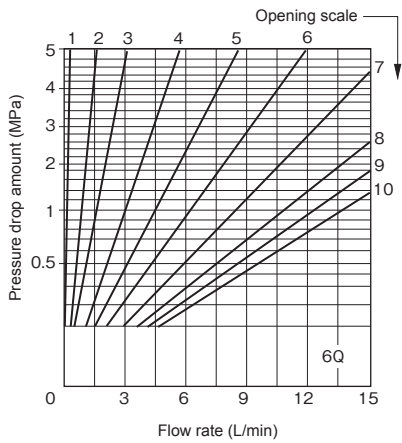
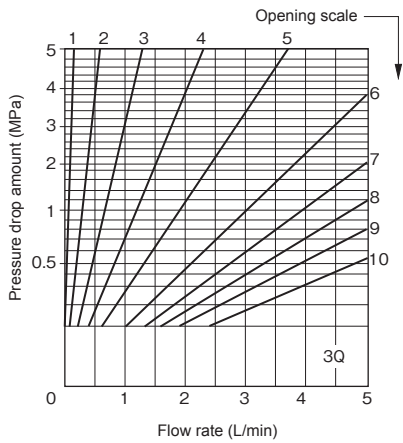
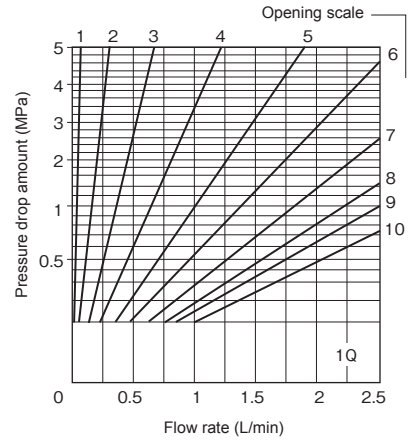
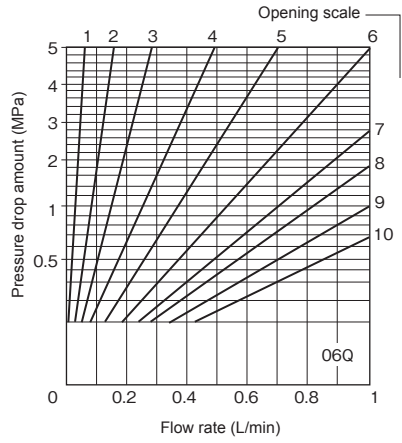
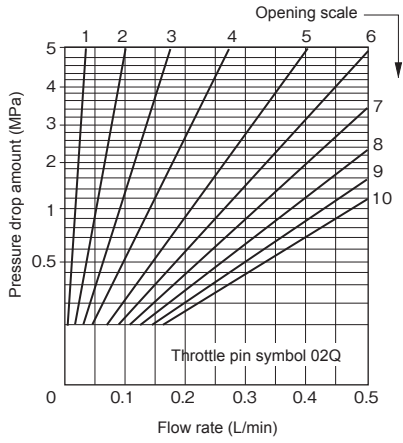

F10

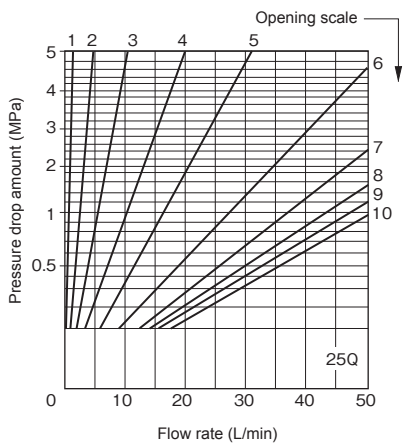
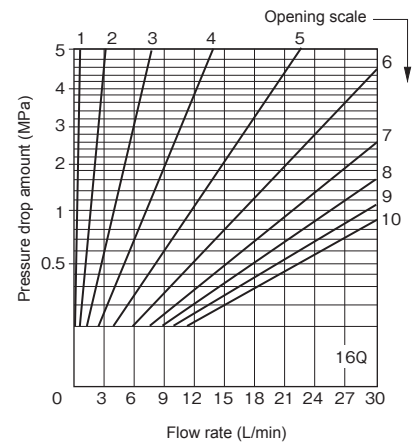
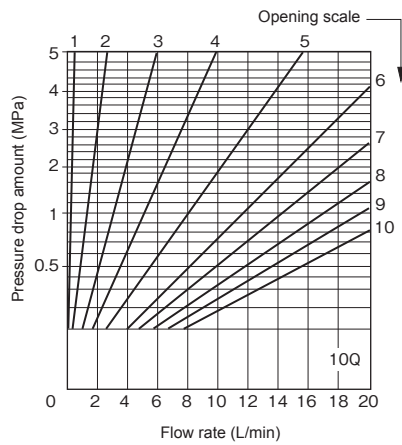
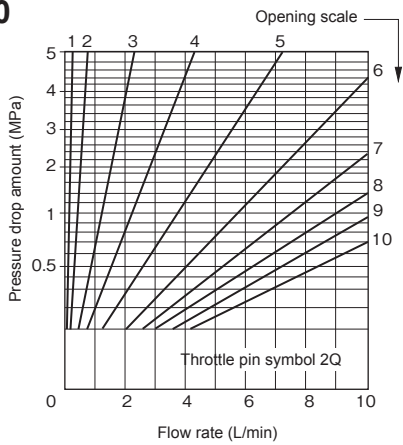

F10

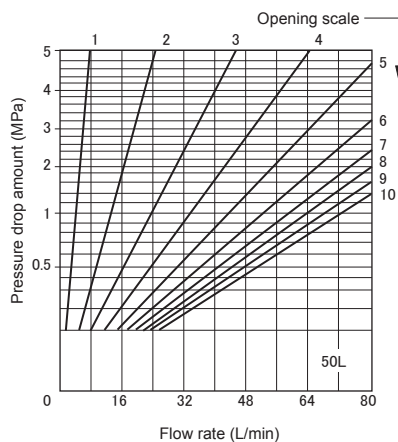
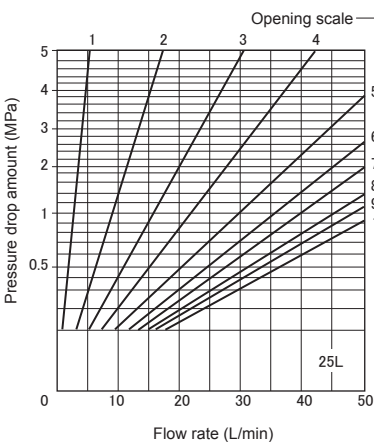
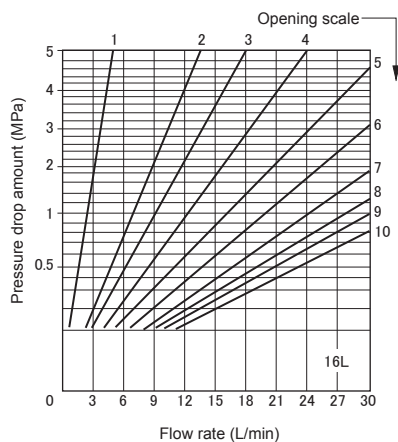
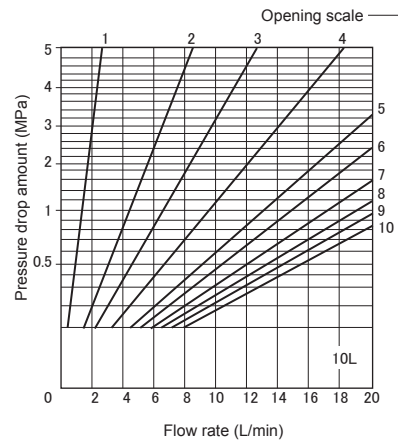
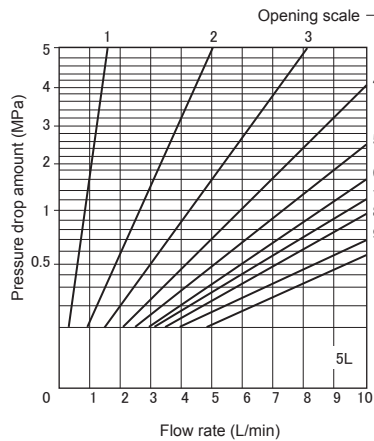
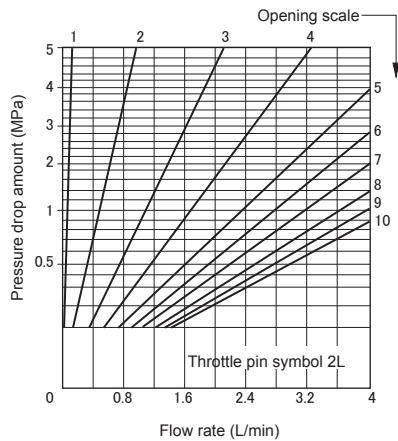

Dimension drawing

F*P

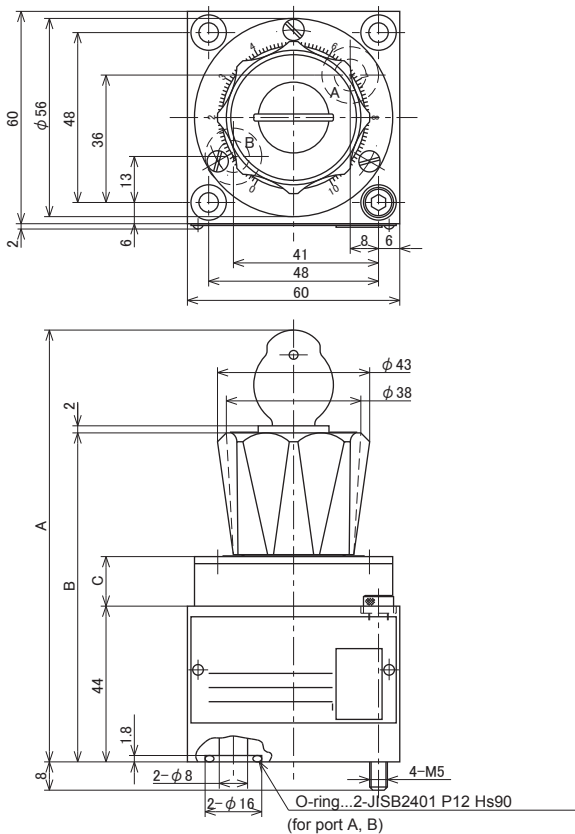

Nominal dimension	A	B	C
5	122	92.5	14
10	124	94.5	16

F*G/R

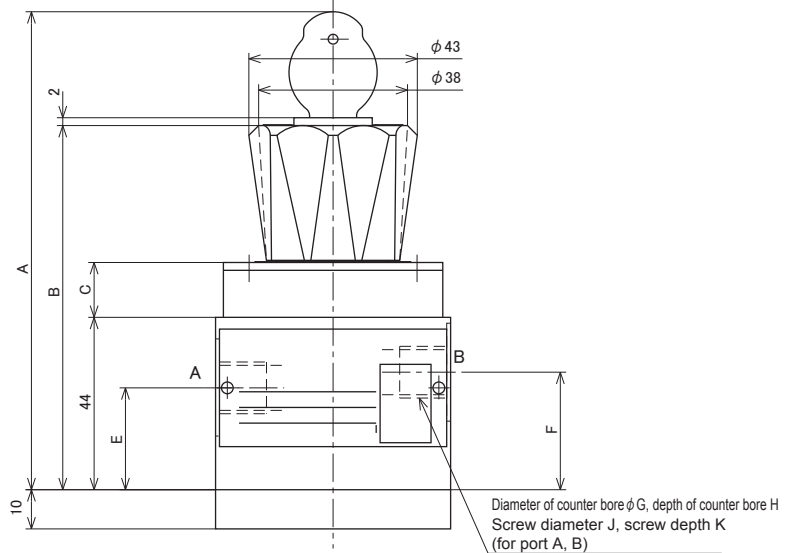
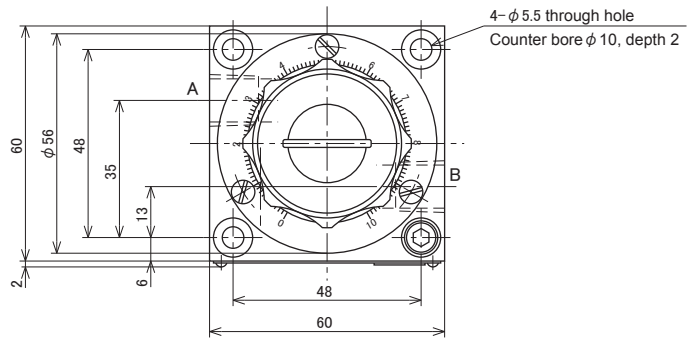

Nominal dimension	A	B	C	E	F	G	H	J	K
5	G	122	92.5	14	26	25	1	G $\frac{1}{4}$	13
	R							Rc $\frac{1}{4}$	12.5
10	G	124	94.5	16	22	25	1	G $\frac{1}{4}$	13
	R							Rc $\frac{1}{4}$	12.5

F*C

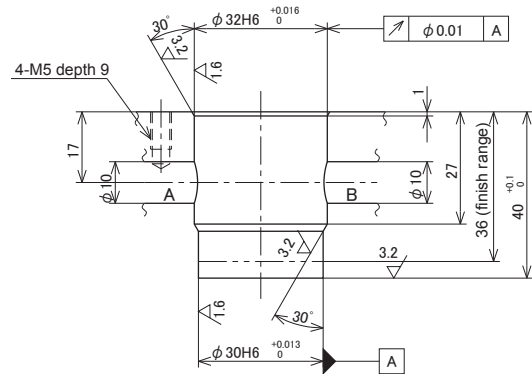
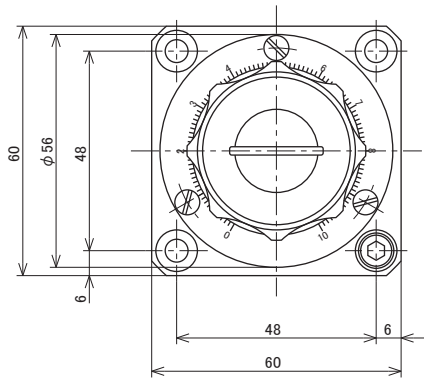

Machining dimension of manifold

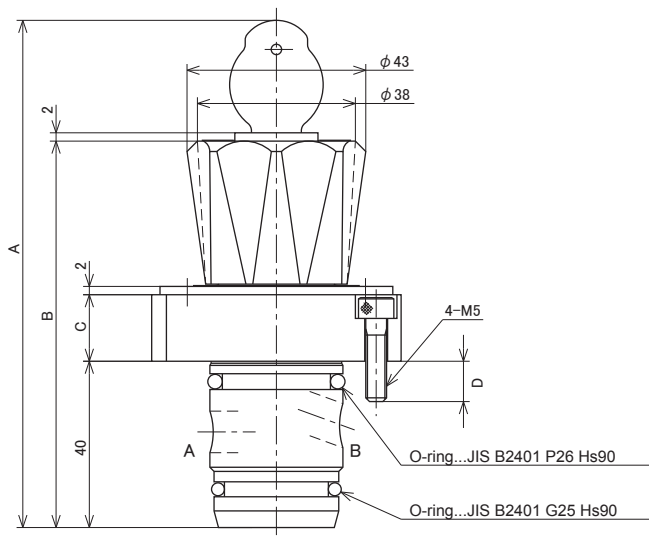

Nominal dimension	A	B	C	D
5	122	92.5	16	8
10	124	94.5	18	6

Temperature and pressure compensated flow regulating valve (1) FJC5 to 16

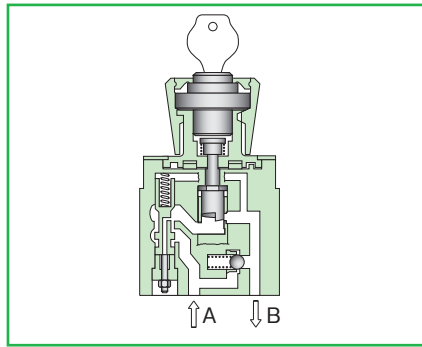

Overview

This temperature and pressure compensated flow regulating valve controls the flow rate of the hydraulic circuit to be constant regardless of change in pressure and temperature and allows for precise speed control of the actuator.

Features

- As the restriction part is of sharp-edged orifice structure, high-precision temperature compensation can be obtained.
- To prevent a jumping phenomenon that occurs at the time of startup of the actuator, a jumping prevention device can be installed.
- A wide variety of types of maximum regulated flow rate are available, optimum control can be performed.
- As the handle key is adopted for the adjusting part, the flow rate does not change even if you touch the handle by mistake other than during adjustment.

Type indication

Temperature and pressure compensated flow regulating valve (1)

F J C 10 P - 11 - 3 / 10 L J -

Temperature and pressure compensated flow regulating valve

Nominal dimension
5, 10, 16

Connection method
P = Gasket connection type

Series number: Nominal dimension 5 = 10
Nominal dimension 10, 16 = 11

Shape of adjustment part
3 = Handle with key adjustment

Type of hydraulic oil
No symbol = Mineral based hydraulic oil
V = Phosphate ester based hydraulic oil
W = Fatty ester based hydraulic oil
Water-glycol based hydraulic oil

Presence/absence of jumping prevention device
No symbol = Without jumping prevention device
J = With jumping prevention device

Maximum regulated flow rate symbol

Hydraulic symbols

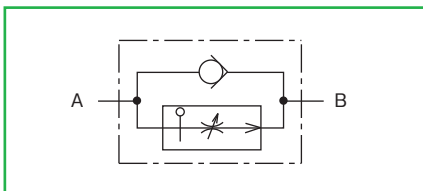

Nominal dimension	5	10	16
Maximum regulated flow rate (L / min)			
0.2	02Q	—	—
0.6	06Q	—	—
1.2	1Q	—	—
3	3Q	—	—
6	6Q	—	—
10	10Q	10L	—
15	15Q	—	—
16	—	16L	—
25	—	25L	—
50	—	50L	—
60	—	—	60L
100	—	—	100L
160	—	—	160L

Option

A temperature and pressure compensated flow regulating valve with a lever in which only the operating part shape is different can be manufactured.

- Type indication: ······Add -C01 to the end. (10 and 16 size only)

Specifications

Nominal dimension		5						10				16				
Maximum working pressure (port A) MPa (kgf/cm ²)		20.6 (210)						30.9 (315)								
Maximum flow rate L/min		0.2	0.6	1.2	3	6	10	15	10	16	25	50	60	100	160	
Minimum controlled flow rate cm ³ /min (Note 1)		25	30	50	80	100	150	200	150	200	200	300	400	1,500	2,000	
Accuracy of flow regulation (%) (with respect to maximum flow rate)	Temperature compensation (-20 to +70°C)	±5		±3		±2										
	Pressure compensation (Nominal dimension 5 has pressure difference of 20.6 MPa (210 kgf/cm ²) Nominal dimension 10 and 16 have pressure difference of 30.9 MPa (315 kgf/cm ²))	±2						±4		±2		±4		±2		±4
Maximum operating pressure difference MPa (kgf/cm ²) (Note 2)		0.4 (4)						0.8 (8)		0.4 (4)		0.6 (6)		0.5 (5)		
Mass kg		1.6						5.6				11.3				

(Note 1) The minimum controlled flow rate shows the maximum leak amount from port A to port B when the adjusted opening is 0.
(port A: Maximum working pressure, port B: 0 Mpa)

(Note 2) This shows the minimum pressure difference between the inlet and outlet necessary for regulating the flow rate. However, if the valve is used with the maximum controlled flow rate, the pressure drop amount inside the valve is added and the pressure difference between the inlet and outlet is approximately 1.0 MPa.

Sub-plate

Valve type	Sub-plate type	Connection diameter	Mass
FJC5P	P-FJC5R14-0	Rc1/4	1kg
	P-FJC5G14-0	G1/4	
FJC10P	P-FJC10R12-0	Rc1/2	2kg
	P-FJC10G12-0	G1/2	
	P-FJC10R34-0	Rc3/4	3kg
	P-FJC10G34-0	G3/4	
FJC16P	P-FJC16R1-0	Rc 1	6kg
	P-FJC16G1-0	G1	
	P-FJC16R54-0	Rc1 1/4	
	P-FJC16G54-0	G1 1/4	

When you use a sub-plate, please place an order for the left sub-plate type. For the dimension drawing, refer to pages 4 and 8 of the appendix.

Accessories

Mounting bolt

Type	Hexagon socket head cap thread	Quantity	Tightening torque N·m (kgf·cm)
FJC5P	M5×50L	4 pcs.	6.9±1.0 (70±10)
FJC10P	M8×50L	4 pcs.	29.4±4.4 (300±45)
FJC16P	M10×75L	4 pcs.	56.8±8.5 (589±87)

Opening - Flow rate characteristics (viscosity 36 mm²/s (cSt))

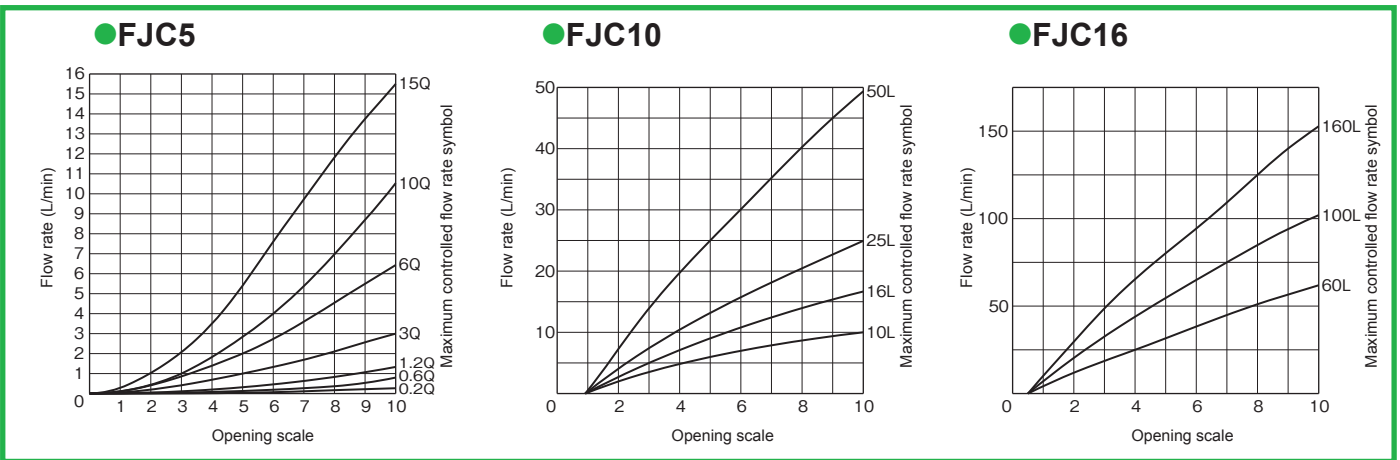

Pressure drop characteristics (viscosity 36 mm²/s (cSt))

In the case of check valve free flow

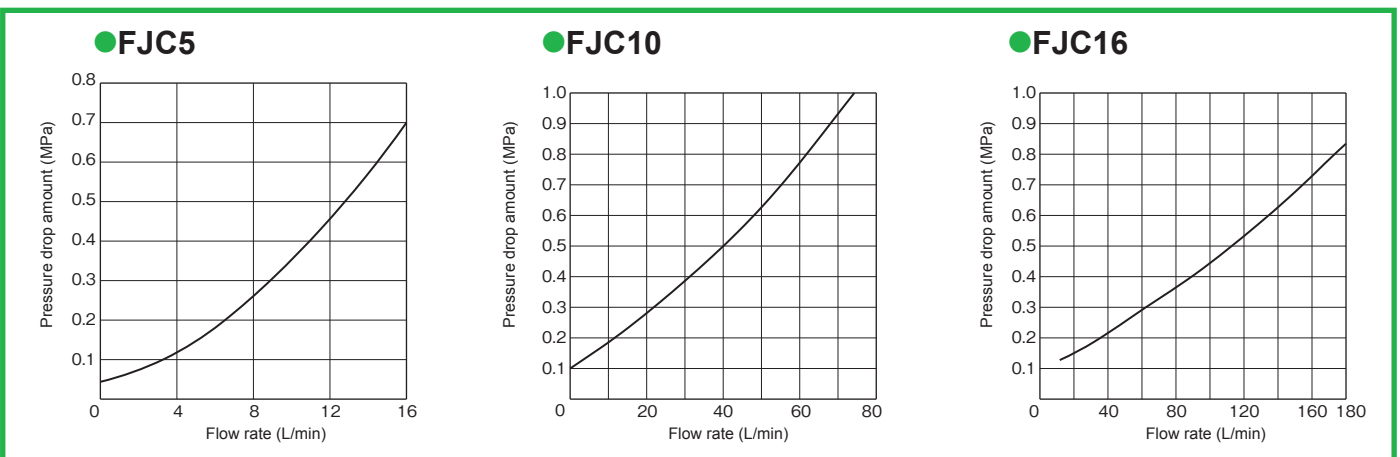

Dimension drawing

FJC5

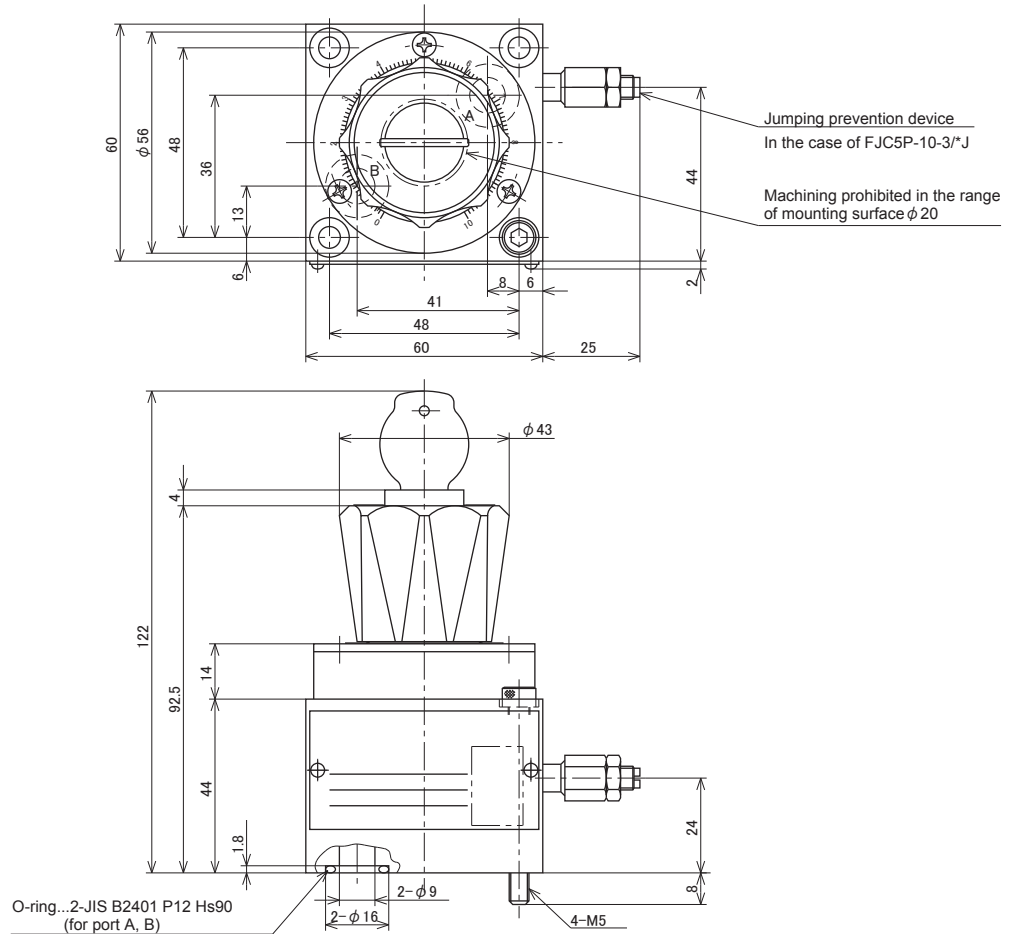

FJC16

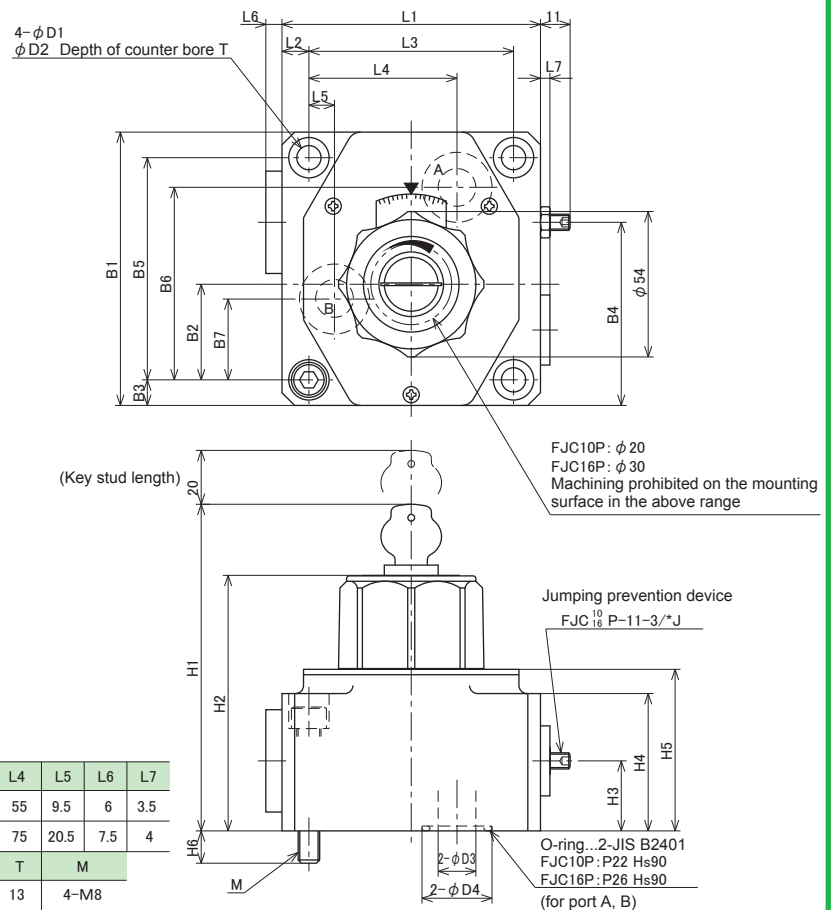

Nominal dimension	B1	B2	B3	B4	B5	B6	B7	L1	L2	L3	L4	L5	L6	L7
10	101.5	35.5	9.5	68	82.5	71.5	30	96	10	76	55	9.5	6	3.5
16	123.5	41.5	11	81.5	101.5	90.5	15	125.5	12	101.5	75	20.5	7.5	4
Nominal dimension	H1	H2	H3	H4	H5	H6	D1	D2	D3	D4	T	M		
10	125	95	26	51	60	12	9	15	14	26	13	4-M8		
16	147	117	34	72	82	15	11	18	20	32	12	4-M10		

Temperature and pressure compensated flow regulating valve (2) FJC30

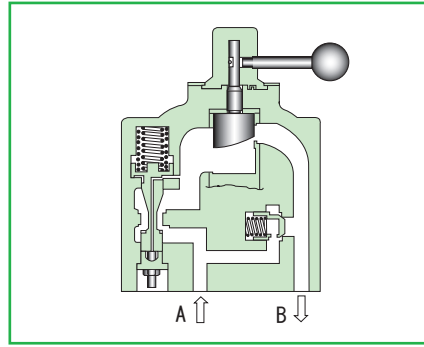

Overview

This temperature and pressure compensated flow regulating valve controls the flow rate of the hydraulic circuit to be constant regardless of change in pressure and temperature and allows for precise speed control of the actuator.

Features

- As the restriction part is of sharp-edged orifice structure, high-precision temperature compensation can be obtained.
- To prevent a jumping phenomenon that occurs at the time of startup of the actuator, a jumping prevention device can be installed.

Type indication

FJC 30 P - 10 - 5 / 250 J -

Temperature and pressure compensated flow regulating valve		Type of hydraulic oil
Nominal dimension	30	No symbol = Mineral based hydraulic oil
Connection method	P = Gasket connection type	V = Phosphate ester based hydraulic oil
Series number: 10		W = Fatty ester based hydraulic oil
Shape of adjustment part	5 = Lever adjustment	Water-glycol based hydraulic oil
		Presence/absence of jumping prevention device
		No symbol = Without jumping prevention device
		J = With jumping prevention device
		Maximum regulated flow rate symbol
		250 = 250 L / min
		350 = 350 L / min

Hydraulic symbols

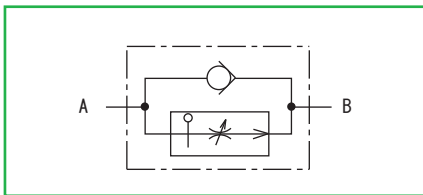

Sub-plate

Valve type	Sub-plate type	Connection diameter	Mass
FJC30P	P-FJC30R54-0	Rc 1/4	28kg
	P-FJC30G54-0	G 1/4	
	P-FJC30R32-0	Rc 1/2	
	P-FJC30G32-0	G 1/2	

When you use a sub-plate, please place an order for the above sub-plate type. For the dimension drawing, refer to page 4 of the appendix.

Specifications

Nominal dimension		30
Maximum working pressure (port A) MPa (kgf/cm ²)		30.9 (315)
Maximum flow rate L/min		250 350
Minimum controlled flow rate cm ³ /min (Note 1)		4
Accuracy of flow regulation (%) (with respect to maximum flow rate)	Temperature compensation (-20 to +70°C)	±3
	Pressure compensation	±5 (when pressure difference is 30.9 MPa (315 kgf/cm ²))
Maximum operating pressure difference MPa (kgf/cm ²) (Note 2)		1.0 (10) 1.8 (18)
Mass kg		32

- (Note 1) The minimum controlled flow rate shows the maximum leak amount from port A to port B when the adjusted opening is 0. (port A: 30.9 MPa, port B: 0 Mpa)
- (Note 2) This shows the minimum pressure difference between the inlet and outlet necessary for regulating the flow rate. However, if the valve is used with the maximum controlled flow rate, the pressure drop amount inside the valve is added and the pressure difference between the inlet and outlet is approximately 2.5 MPa.

Accessories

Mounting bolt

Type	Hexagon socket head cap thread	Quantity	Tightening torque N·m (kgf·cm)
FJC30P	M20 × 110L	4 pcs.	431.2 ± 64.6 (4400 ± 660)

Opening - Flow rate characteristics

(viscosity 60 to 80 mm²/s (cSt))

(Pressure difference 10 MPa constant)

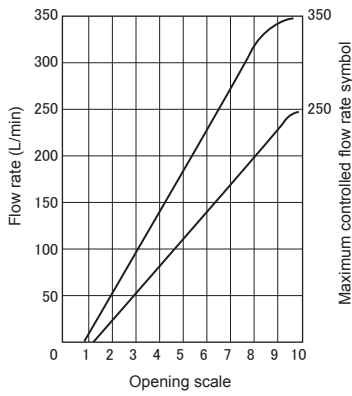

Pressure - Flow rate characteristics (viscosity 60 to 80 mm²/s (cSt))

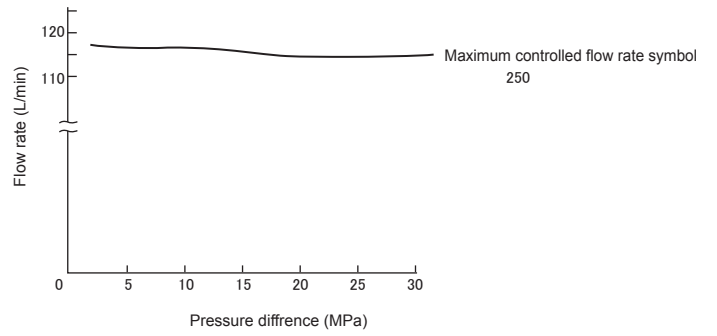

Dimension drawing

FJC30

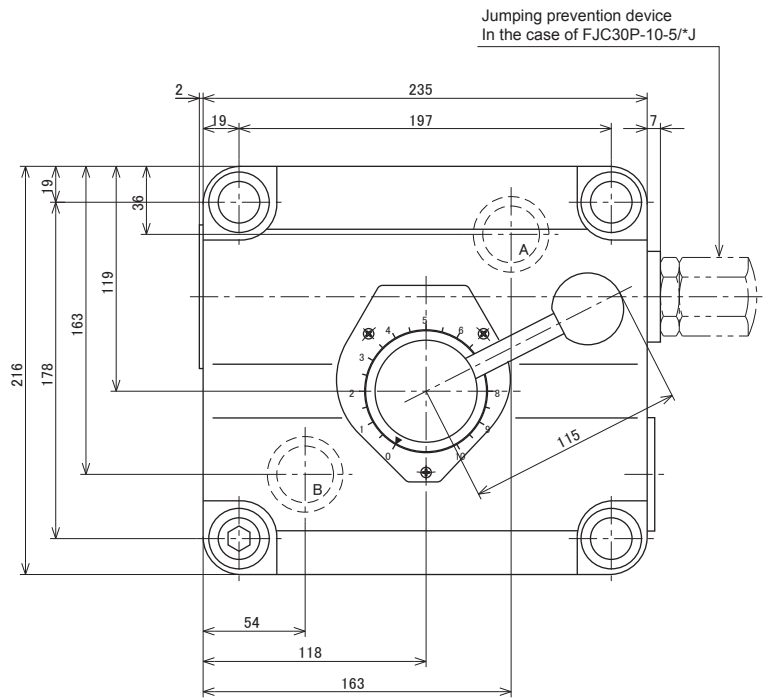
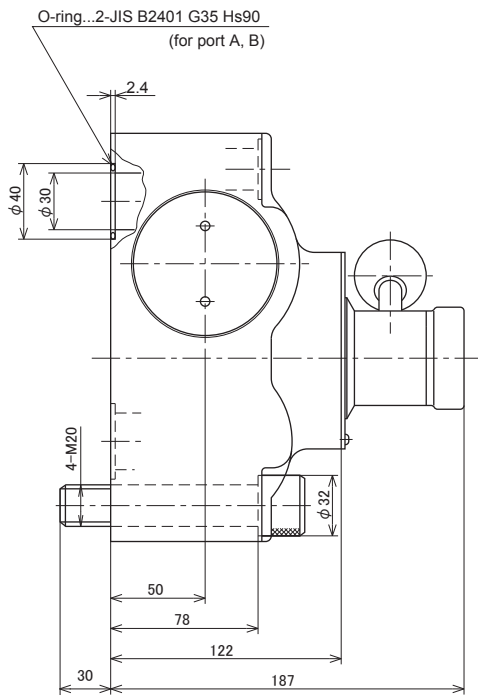

Flow regulating valve (2)

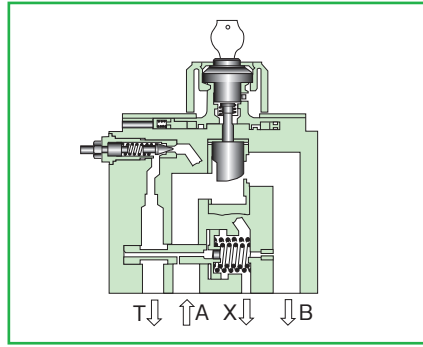

Overview

This three-way flow regulating valve is an energy-saving type flow regulating valve that has both the meter-in flow regulating function and pressure regulating function. By using this valve, only the flow rate corresponding to the opening setting is supplied to the load side and excess oil is bled off. At that time, as the inlet side pressure is kept slightly higher than the load pressure, energy consumption is substantially reduced.

Features

1. As the restriction part is of sharp-edged orifice structure, high-precision temperature compensation can be obtained.
2. As the handle key is adopted for the adjusting part, the flow rate does not change even if you touch the handle by mistake other than during adjustment.
3. The three-way flow regulating valve with a relief valve for restricting the maximum pressure or the valve with a port for vent unloading is available.

Type indication

FK 10 P - 11 - 3 / 10L R X -

Three-way flow regulating valve

Nominal dimension

10, 16

Connection method

P = Gasket connection type

Series number: 11

Shape of adjustment part

3 = Handle with key adjustment

Maximum regulated flow rate symbol

Type of hydraulic oil

- No symbol = Mineral based hydraulic oil
- V = Phosphate ester based hydraulic oil
- W = Fatty ester based hydraulic oil
- Water-glycol based hydraulic oil

Presence/absence of unloading port

- No symbol = Without port X
 - X = With port X
- (however, nominal dimension 10 is all "X".)

Presence/absence of relief valve

- No symbol = Without relief valve
- R = With relief valve

Nominal dimension	10	16
Maximum regulated flow rate (L / min)		
10	10L	—
16	16L	—
25	25L	—
50	50L	—
60	—	60L
100	—	100L
160	—	160L

Hydraulic symbols

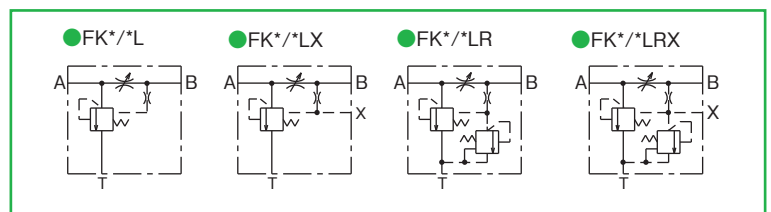

Specifications

Nominal dimension		10				16		
Maximum working pressure (port A) MPa (kgf/cm ²)		30.9 (315)						
Maximum controlled flow rate L/min (port A→B)		10	16	25	50	60	100	160
Minimum controlled flow rate cm ³ /min (Note 1)		150	200	200	300	400	1,500	2,000
Maximum pump flow rate L/min		50		100	320			
Accuracy of flow regulation (%) (with respect to maximum flow rate)	Temperature compensation (-20 to +70°C)	±2						
	Pressure compensation	Refer to "Pressure - Flow rate characteristics" below.						
Maximum operating pressure difference MPa (kgf/cm ²) (Note 2)		0.4 (4)		0.6 (6)	0.5 (5)			
Mass kg		5.6				11.3		

(Note 1) The minimum controlled flow rate shows the maximum leak amount from port A to port B when the adjusted opening is 0. (port A: Maximum working pressure, port B: 0 Mpa)

(Note 2) This shows the minimum pressure difference between the inlet and outlet necessary for regulating the flow rate. However, if the valve is used with the maximum regulated flow rate, the pressure drop amount inside the valve is added and the pressure difference between the inlet and outlet is approximately 1 MPa.

Sub-plate

Valve type	Sub-plate type	Connection diameter	Mass
FK10P	P-FK10R12-0	Rc $\frac{1}{2}$	2.8 kg
	P-FK10G12-0	G $\frac{1}{2}$	
FK16P	P-FK16R1-0	Rc1	7.3 kg
	P-FK16G1-0	G1	

When you use a sub-plate, please place an order for the left sub-plate type. For the dimension drawing, refer to page 12 of the appendix.

Accessories

● Mounting bolt

Type	Hexagon socket head cap thread	Quantity	Tightening torque N·m (kgf·cm)
FK10P	M8×50L	4 pcs.	29.4±4.4 (300±45)
FK16P	M10×75L	4 pcs.	56.8±8.5 (580±87)

Pressure - Flow rate characteristics (viscosity 36 mm²/s (cSt))

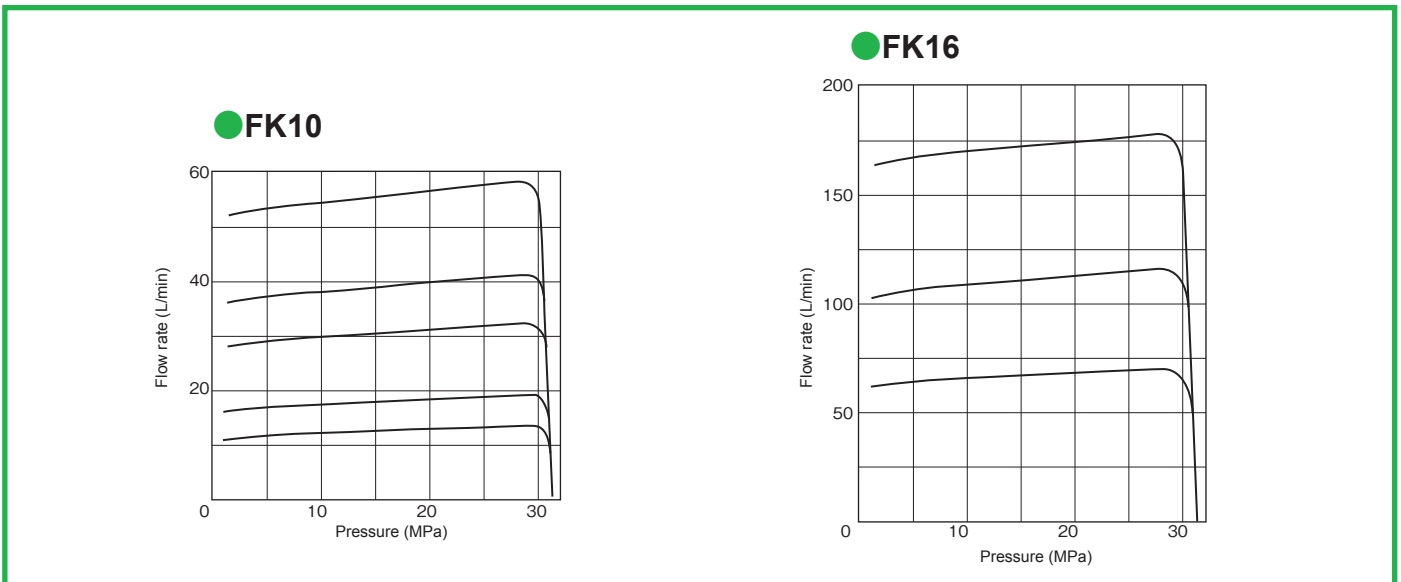

Pressure override characteristics (viscosity 36 mm²/s (cSt))

In the case with relief valve

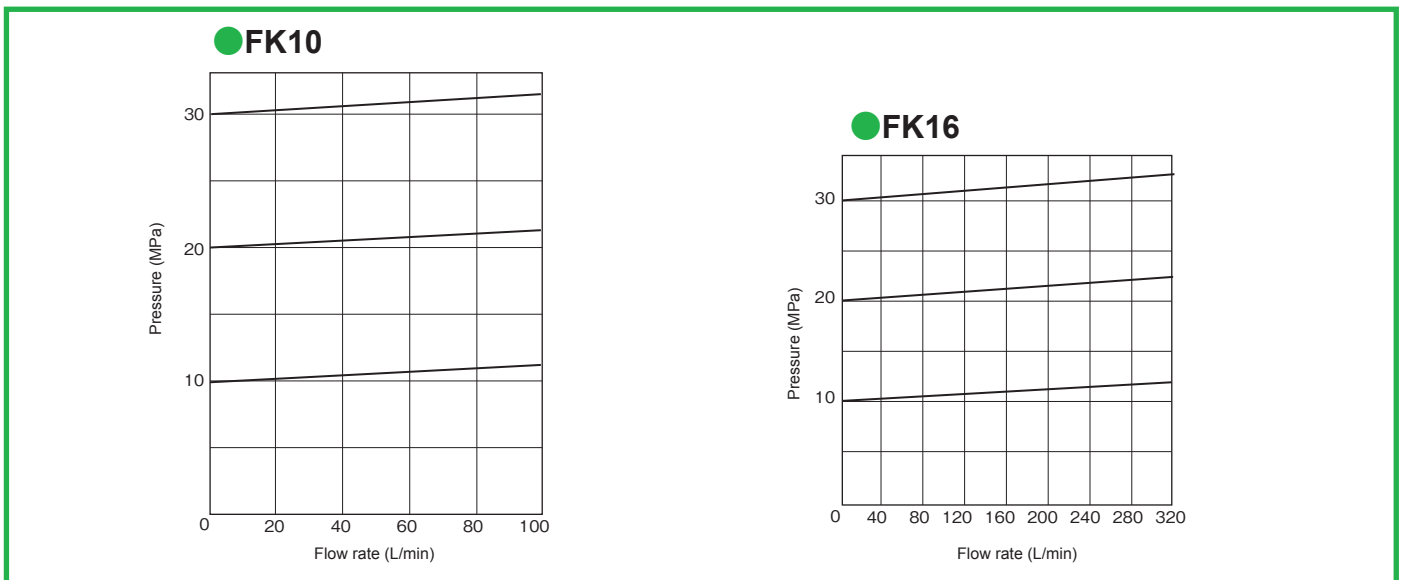

Dimension drawing

●FK10

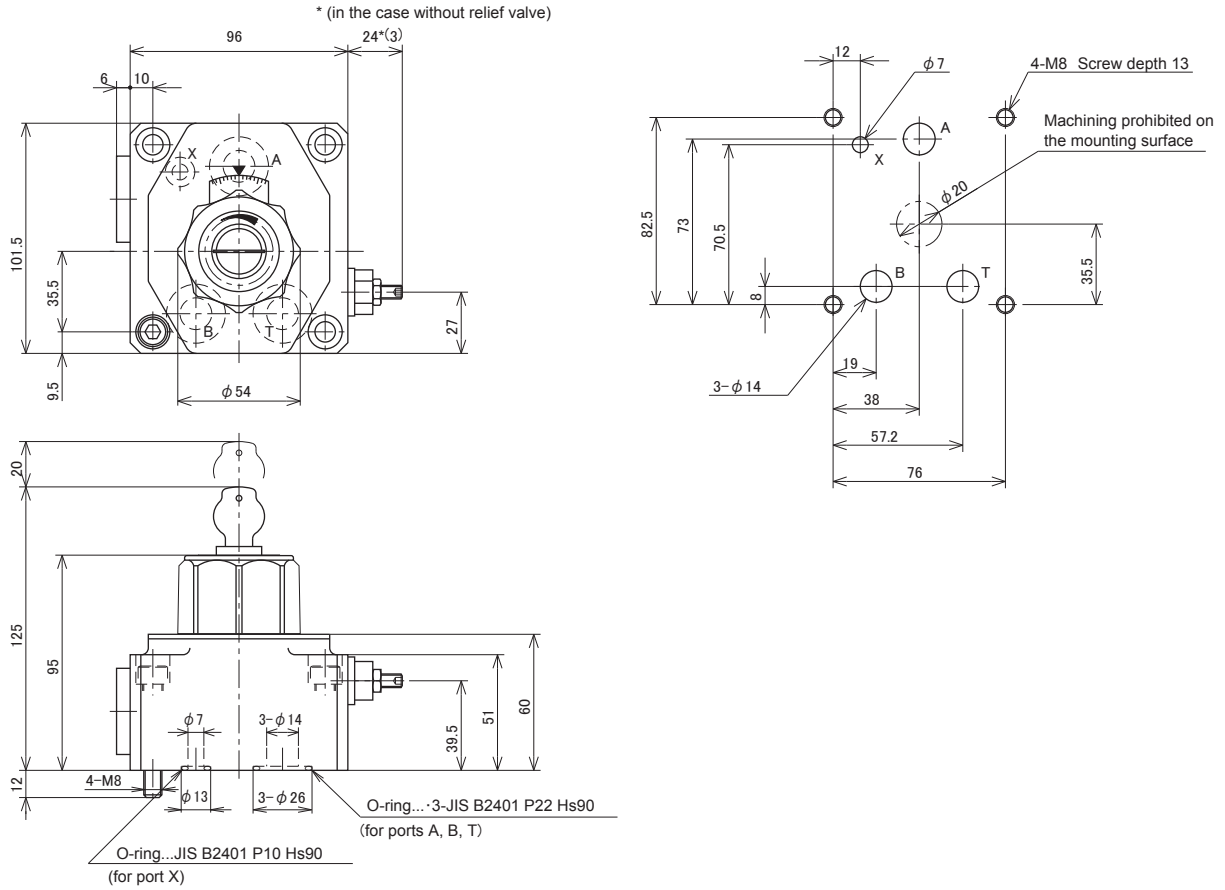

●FK16

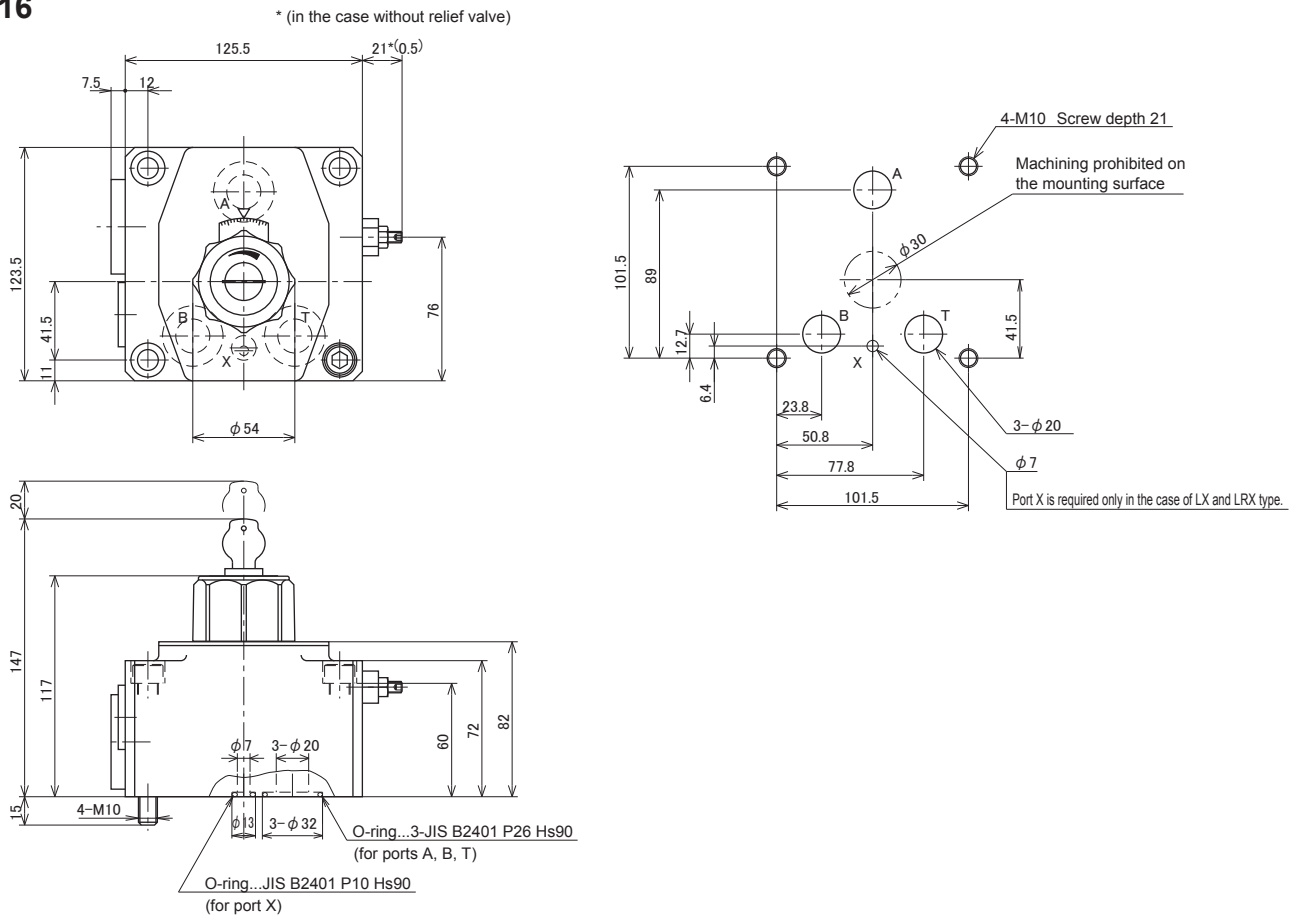

Sandwich valve

As the mounting dimension of the sandwich valve matches that of the solenoid operated directional valve, the hydraulic circuit can be configured only by inserting it between the solenoid operated directional valve and the manifold or the sub-plate.

Page

Check valve	S-(2)C	4-2
Pilot operated check valve	S-(2)CH	4-5
Relief valve	S-(2)RB	4-9
Sequence valve – Direct operated	S-SD	4-12
Pressure reducing valve – Direct operated	S-PRD	4-16
Throttle valve	S-(2)T	4-20
Slow return check valve	S-(2)TC	4-26
Check valve block	S-4C	4-33
Check valve block	ZA	4-36
Shock damping valve	ZNS	4-39

(Note) The mounting bolt dimension of the solenoid operated directional valve manufactured by us is as shown in the table below.

Valve type	Mounting bolt dimension	Tightening torque N·m (kgf·cm)
DE6 (20, 30 series)	M5-45*	6.4 ± 0.5 (65 ± 5)
DE10 (20 series)	M6-35*	13 ± 1 (133 ± 10)

*The mounting bolt dimension in the case of 10 Series is as shown in the table below.

Valve type	Mounting bolt dimension	Tightening torque N·m (kgf·cm)
DE6 (10 series)	M5-50	7.4 ± 0.5 (75 ± 5)
DE10 (10 series)	M6-50	11.8 ± 1.7 (120 ± 18)

In the type selection, we recommend the one indicated in color letters in the type indication explanation.

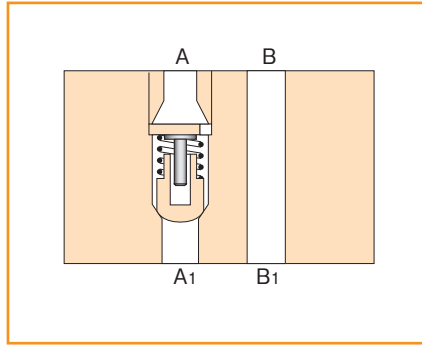

Type indication

S - C 6 - 11 - T 05 -

Sandwich type

Check valve

- C = Single type
- 2C = Double type

Nominal dimension

6, 10

Series number: 11

Type of hydraulic oil

- No symbol = Mineral based hydraulic oil
- V = Phosphate ester based hydraulic oil
- W = Fatty ester based hydraulic oil
- Water-glycol based hydraulic oil

Cracking pressure

05 = 0.05MPa (0.5kgf/cm²)

Check valve incorporated port symbol

	Symbol	Check valve incorporated port	Direction of free flow
C	T	Port T	T → T ₁
	P	Port P	P ₁ → P
	A	Port A	A ₁ → A
	B	Port B	B ₁ → B
	C	Port A	A → A ₁
2C	D	Port B	B → B ₁
	E	Port A Port B	A → A ₁ B → B ₁

Specifications

Nominal dimension	6	10
Maximum working pressure MPa (kgf/cm ²)	30.9 (315)	
Maximum flow rate L/min	40	100
Cracking pressure MPa (kgf/cm ²)	0.05 (0.5)	
Mass kg	0.9	2.4

Mounting bolt

Type	Hexagon socket head cap thread	Quantity	Tightening torque N·m (kgf·cm ²)
C6	M5×85L	4 pcs.	6.4±0.5 (65±5)
C10	M6×85L	4 pcs.	13 ± 1 (133±10)

When the solenoid valve is 10 Series, mounting bolts are as shown in the table below.

Type	Hexagon socket head cap thread	Quantity	Tightening torque N·m (kgf·cm ²)
C6	M5×90L	4 pcs.	7.4±0.5 (75 ± 5)
C10	M6×100L	4 pcs.	11.8 ± 1.7 (120±18)

Pressure drop characteristics (viscosity 36 mm²/s (cSt))

When the throttle valve is fully open and the check valve is free flow

S-(2)C6

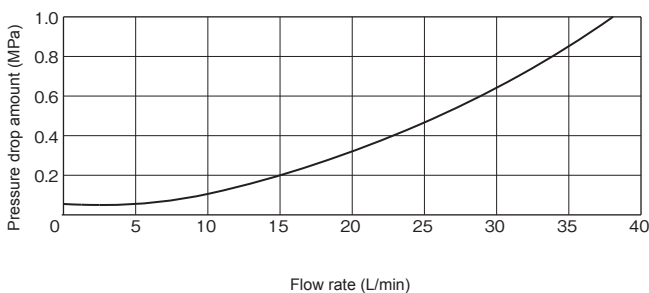

S-(2)C10

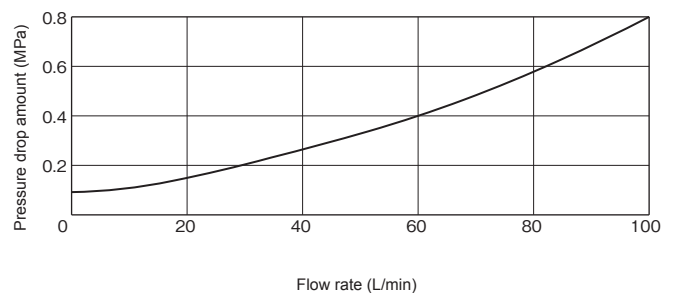

● Hydraulic symbols

● S-C6-11-A

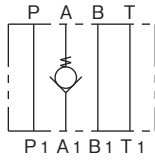

● S-C10-11-A

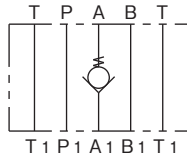

● S-C6-11-B

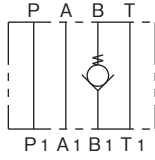

● S-C10-11-B

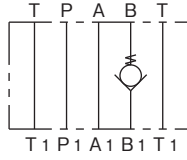

● S-C6-11-P

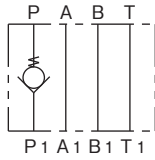

● S-C10-11-P

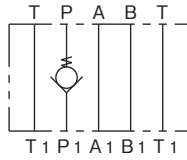

● S-C6-11-C

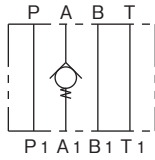

● S-C10-11-C

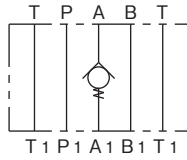

● S-C6-11-D

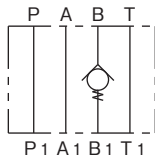

● S-C10-11-D

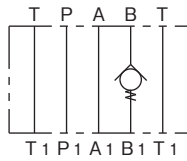

● S-C6-11-T

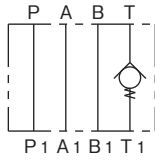

● S-C10-11-T

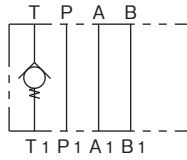

● S-2C6-11-E

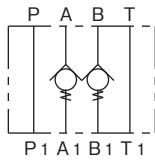

● S-2C10-11-E

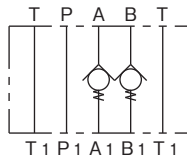

(Note) P1, A1, B1 and T1 show ports on the sub-plate side while P, A, B and T show ports on the selector valve side.

Dimension drawing

● S-(2)C6

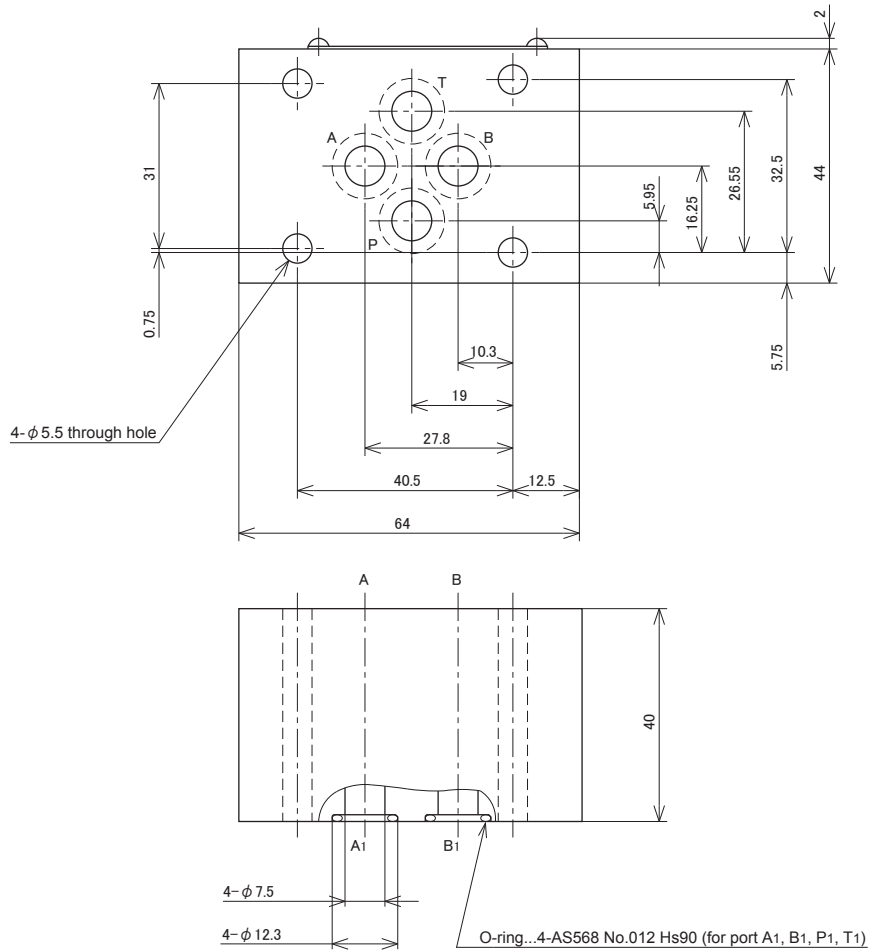

● S-(2)C10

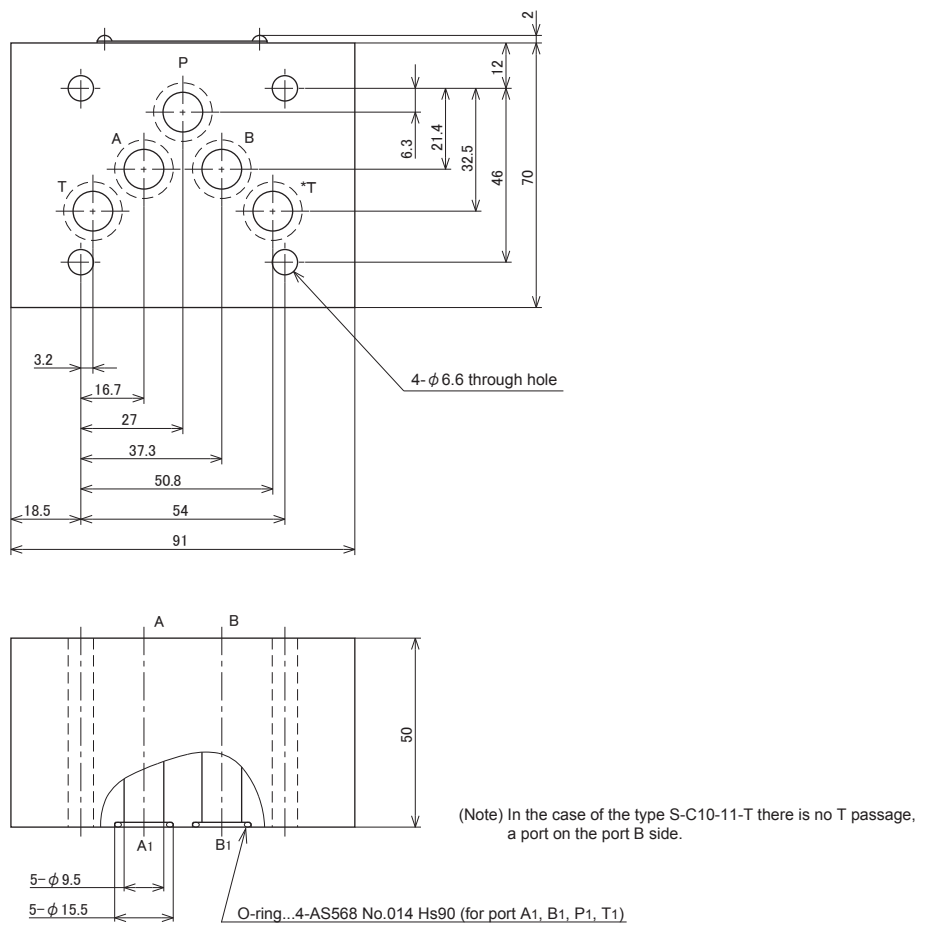

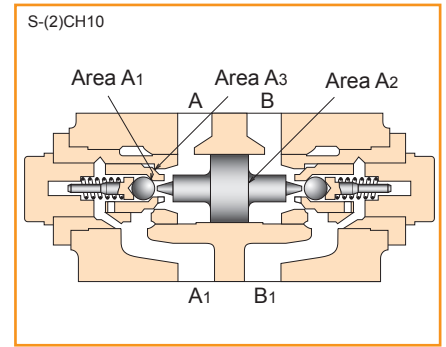
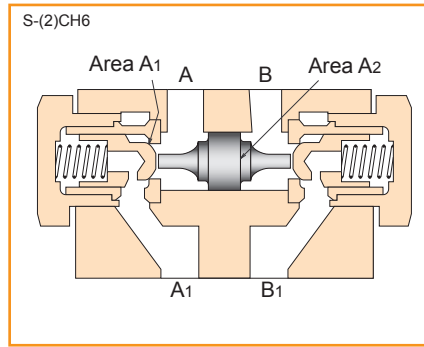

Type indication

S - CH6 - 11 - A -

Sandwich type

Pilot operated check valve

CH = Single type
2CH = Double type

Nominal dimension

6, 10, 16, 22

Mounting bolt

Type	Hexagon socket head cap thread	Quantity	Tightening torque N·m (kgf·cm ²)
S-(2)CH6	M5 ×85L*	4 pcs.	6.4 ± 0.5 (65 ± 5)
S-(2)CH10	M6 ×85L*	4 pcs.	13 ± 1 (133 ± 10)
S-(2)CH16	M6 ×135L	2 pcs.	11.8 ± 1.7 (120 ± 18)
	M10×140L	4 pcs.	56.8 ± 8.5 (580 ± 87)
S-(2)CH22	M12×160L	6 pcs.	98.0 ±14.7 (1000 ±150)

*When the solenoid valve is 10 Series, mounting bolts are as shown in the table below.

Type	Hexagon socket head cap thread	Quantity	Tightening torque N·m (kgf·cm ²)
S-(2)CH6	M5×90L	4 pcs.	7.4 ± 0.5 (75 ± 5)
S-(2)CH10	M6×100L	4 pcs.	11.8 ± 1.7 (120 ± 18)

Hydraulic symbols

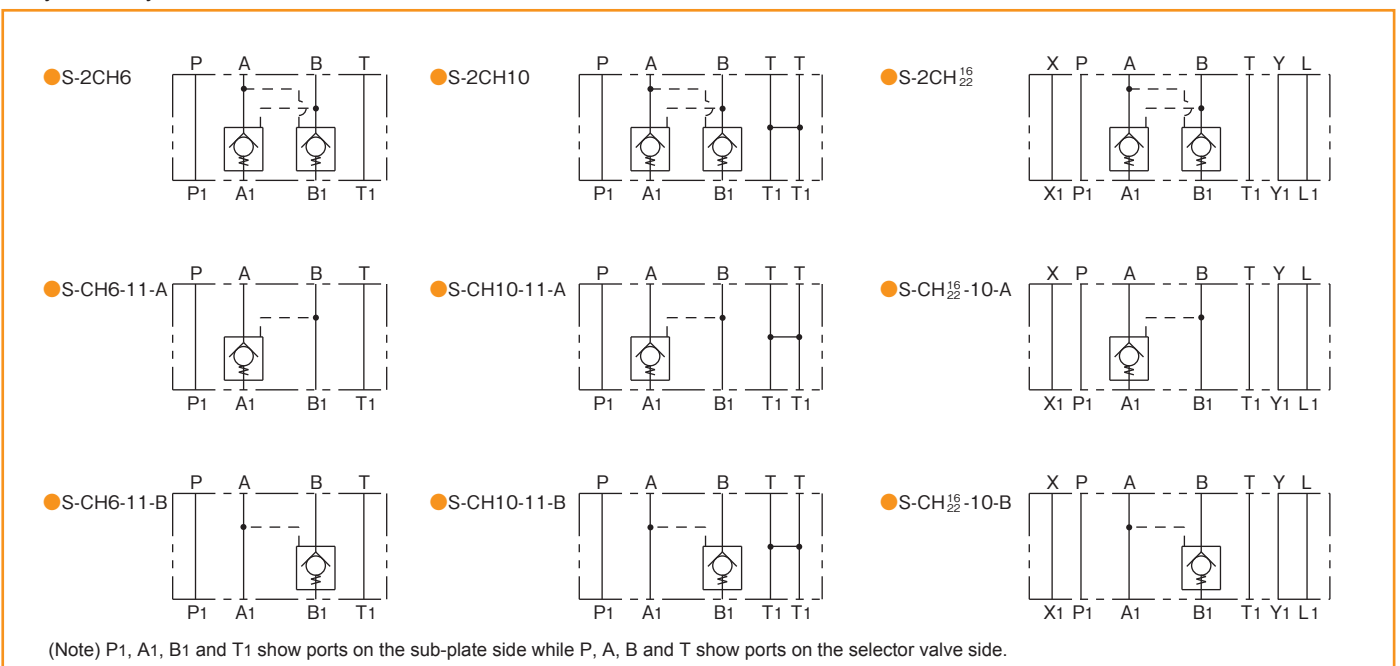

(Note) P1, A1, B1 and T1 show ports on the sub-plate side while P, A, B and T show ports on the selector valve side.

Type of hydraulic oil

No symbol = Mineral based hydraulic oil
V = Phosphate ester based hydraulic oil
W = Fatty ester based hydraulic oil
Water-glycol based hydraulic oil

Check valve incorporated port symbol

	Symbol	Check valve incorporated port	Direction of free flow
2CH	No symbol	Port A	A → A1
		Port B	B → B1
CH	A	Port A	A → A1
	B	Port B	B → B1

Series number:

Nominal dimension 6, 10 = 11
Nominal dimension 16, 22 = 10

Specifications

Nominal dimension		6	10	16	22
Maximum working pressure MPa (kgf/cm ²)		30.9(315)			
Maximum flow rate L/min		50	80	200	300
Cracking pressure MPa (kgf/cm ²)		0.1(1)	0.05(0.5)	0.1(1)	
Area ratio (Refer to the inside structural drawing.)	$\frac{A_1}{A_2}$	$\frac{1}{2.97}$	$\frac{1}{10.89}$	$\frac{1}{11.88}$	$\frac{1}{12.3}$
	$\frac{A_3}{A_2}$	—	$\frac{1}{2.78}$	$\frac{1}{2.77}$	$\frac{1}{2.78}$
Mass kg		0.9	2.2	7.0	11.2

Precautions in use

- To securely close the check valve, connect both A and B ports to the tank line when the directional control valve is at neutral position.

(example of use)

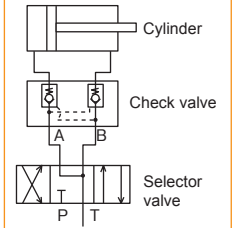

Pressure drop characteristics (viscosity 36 mm²/s (cSt))

● S-(2)CH6

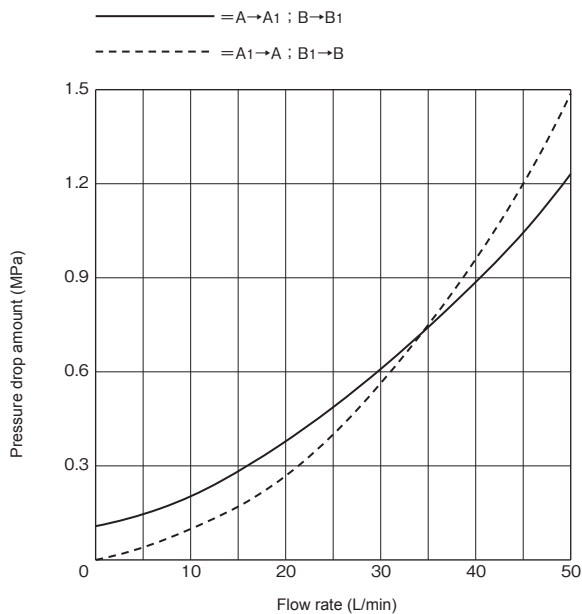

● S-(2)CH10

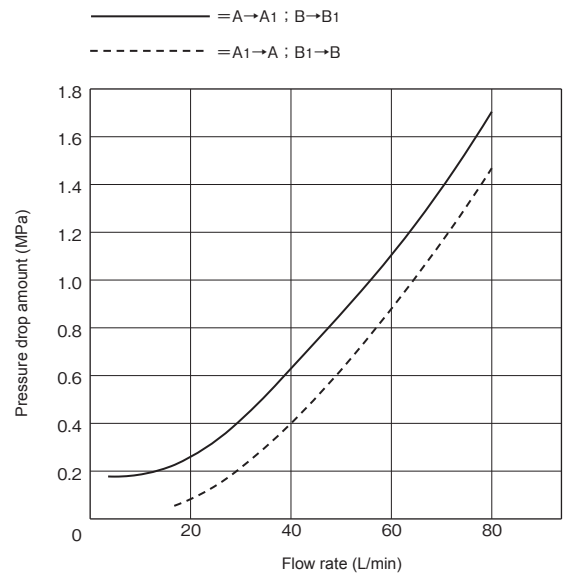

● S-(2)CH16

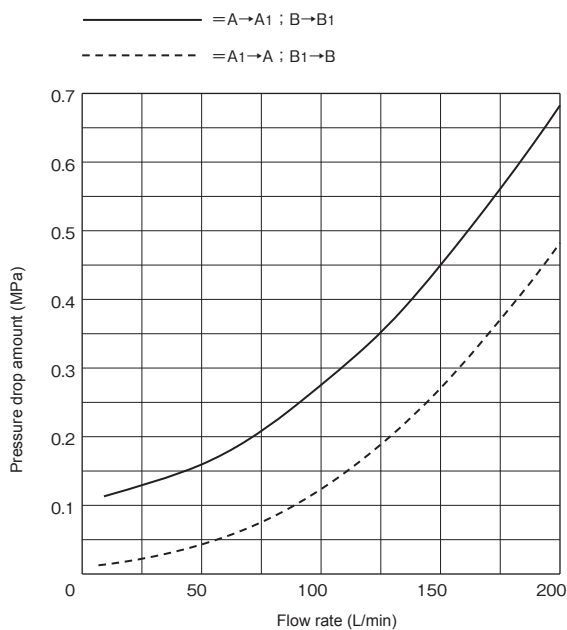

● S-(2)CH22

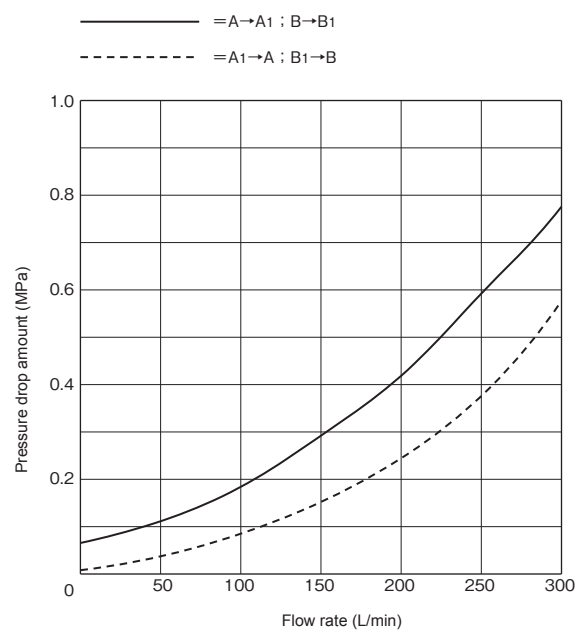

Dimension drawing

● S-(2)CH6

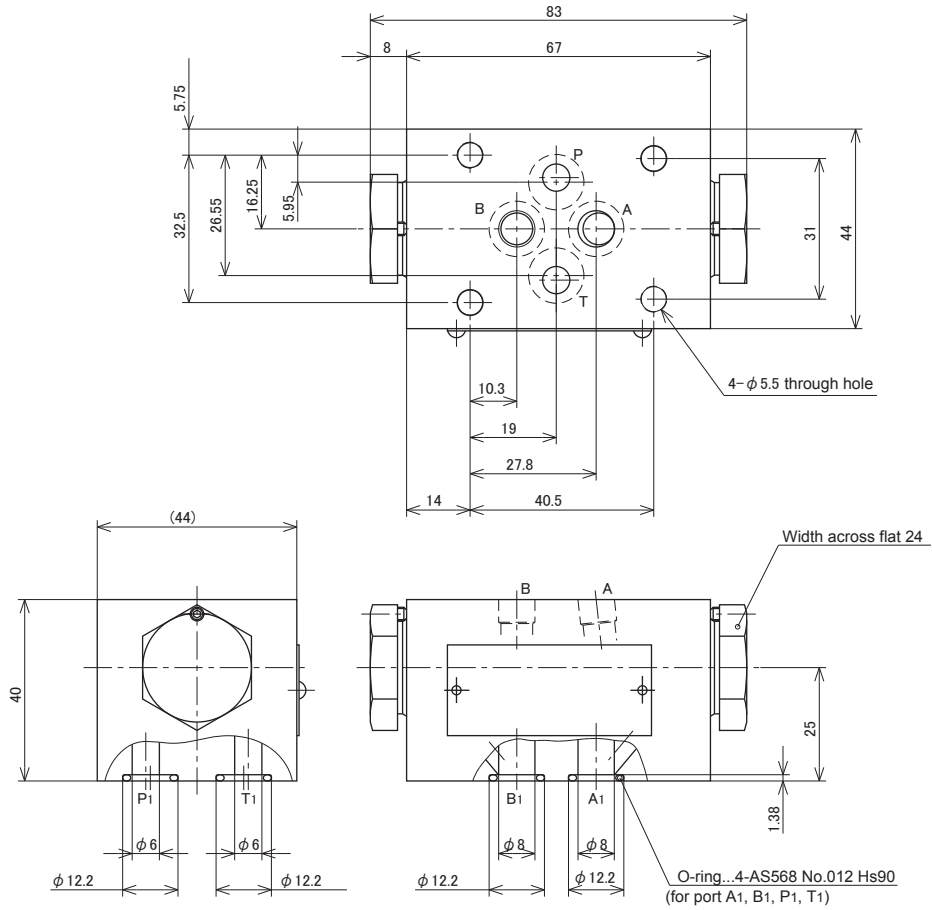

● S-(2)CH10

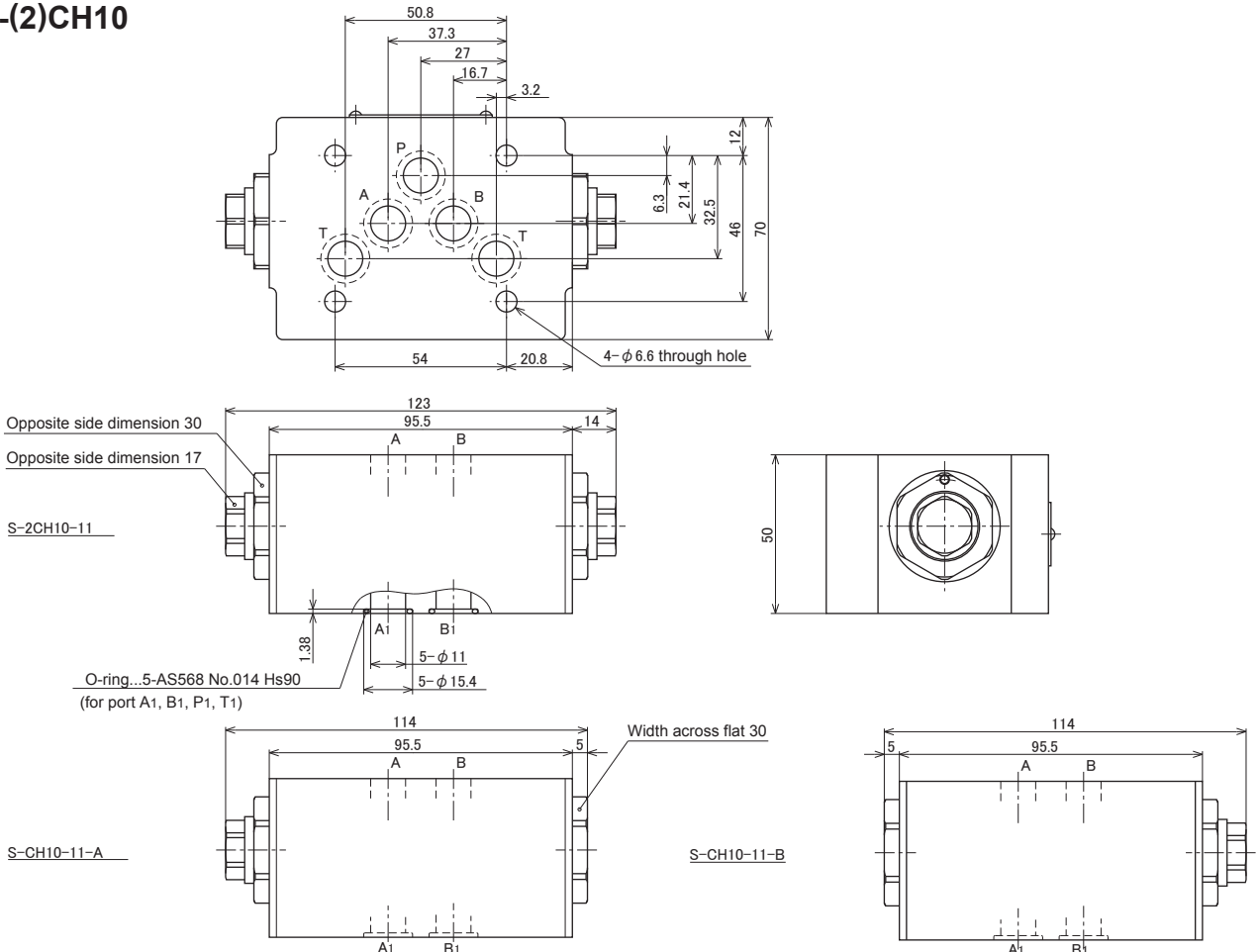

● S-(2)CH16

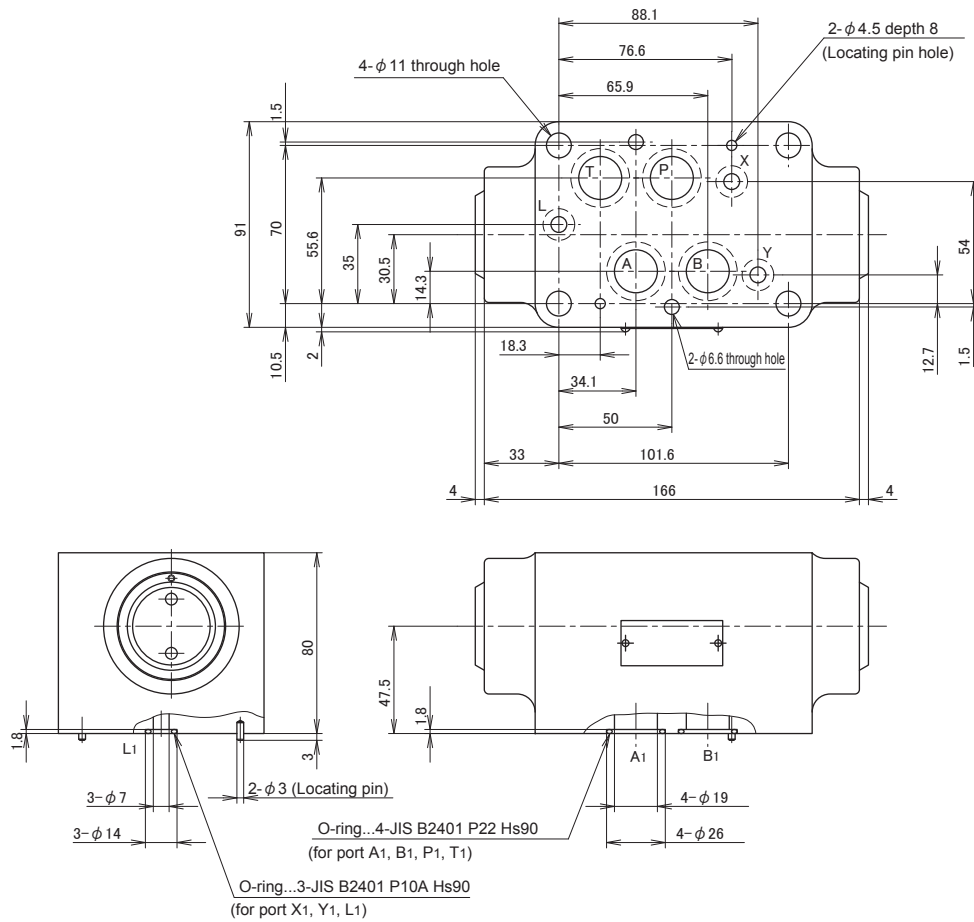

● S-(2)CH22

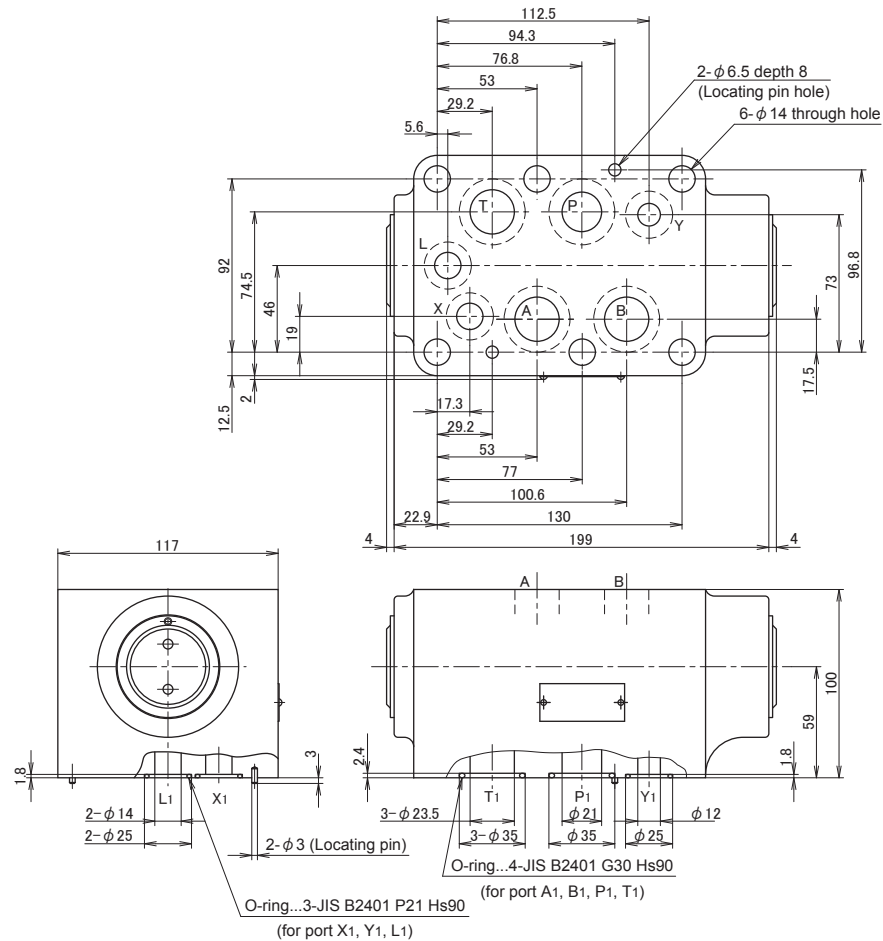

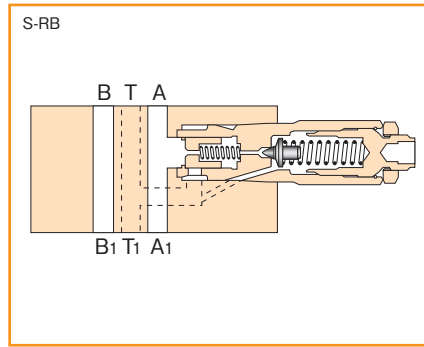

Type indication

S - RB 6 - 10 - A 4 / 315 -

Sandwich type

Relief valve

RB = Single type

2RB = Double type

Nominal dimension

6, 10

Series number: 10

Relief valve incorporated port symbol

Type of hydraulic oil

No symbol = Mineral based hydraulic oil

V = Phosphate ester based hydraulic oil

W = Fatty ester based hydraulic oil

Water-glycol based hydraulic oil

Highest adjustment pressure

100 = 9.8MPa (100kgf/cm²)

315 = 30.9MPa (315kgf/cm²)

Shape of adjustment part

4 = Thread adjustment (without cap)

	Symbol	Incorporated port	Flow direction of relief
RB	A	Port A	A → T
	B	Port B	B → T
	P	Port P	P → T
2RB	E	Port A	A → T
		Port B	B → T
	F	Port A	A → B
		Port B	B → A

● The relief valve - balance piston and cartridge type (refer to the section of the type number index of "RB1M6, 10") is used for the relief valve.

Hydraulic symbols

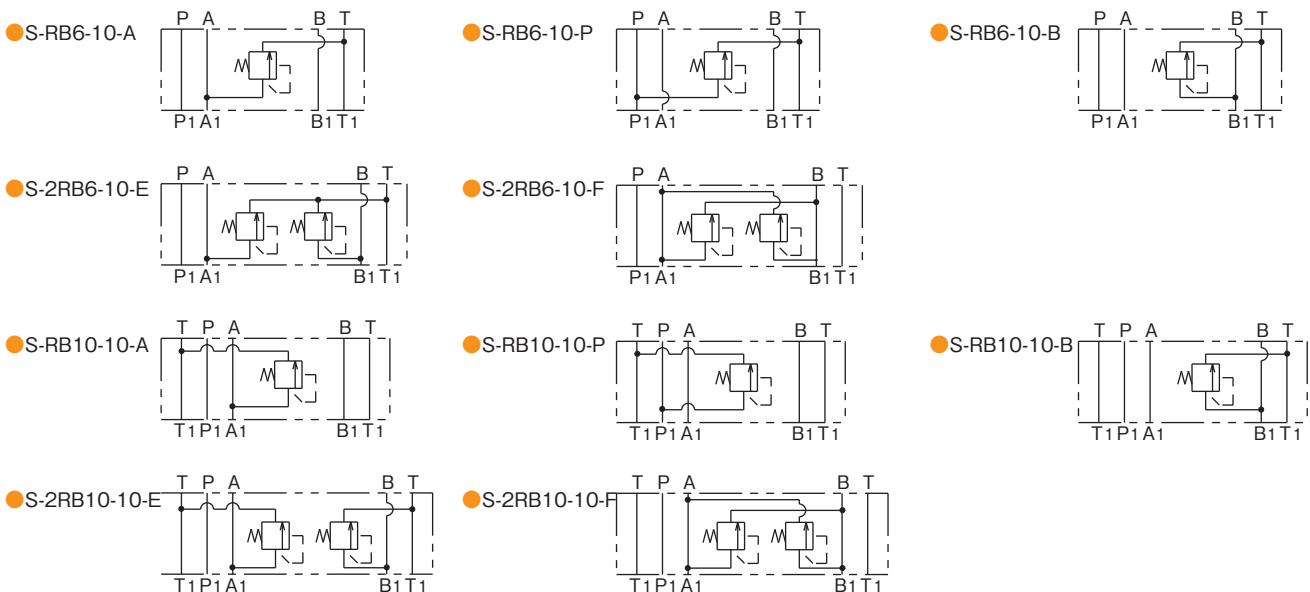

(Note) P1, A1, B1 and T1 show ports on the sub-plate side while P, A, B and T show ports on the selector valve side.

Specifications

Nominal dimension		6	10
Maximum working pressure MPa (kgf/cm ²)		30.9 (315)	
Maximum flow rate L/min		60	100
Highest adjustment pressure MPa (kgf/cm ²)		9.8 (100) or 30.9 (315)	
Mass kg	S-RB	0.95	2.0
	S-2RB	1.2	2.5

● Mounting bolt

Type	Hexagon socket head cap thread	Quantity	Tightening torque N·m (kgf·cm ²)
S-(2)RB6	M5×85L	4 pcs.	6.4±0.5 (65±5)
S-(2)RB10	M6×85L	4 pcs.	13±1 (133±10)

When the solenoid valve is 10 Series, mounting bolts are as shown in the table below.

Type	Hexagon socket head cap thread	Quantity	Tightening torque N·m (kgf·cm ²)
S-(2)RB6	M5×90L	4 pcs.	7.4±0.5 (75±5)
S-(2)RB10	M6×100L	4 pcs.	11.8±1.7 (120±18)

Pressure override characteristics (viscosity 36 mm²/s (cSt))

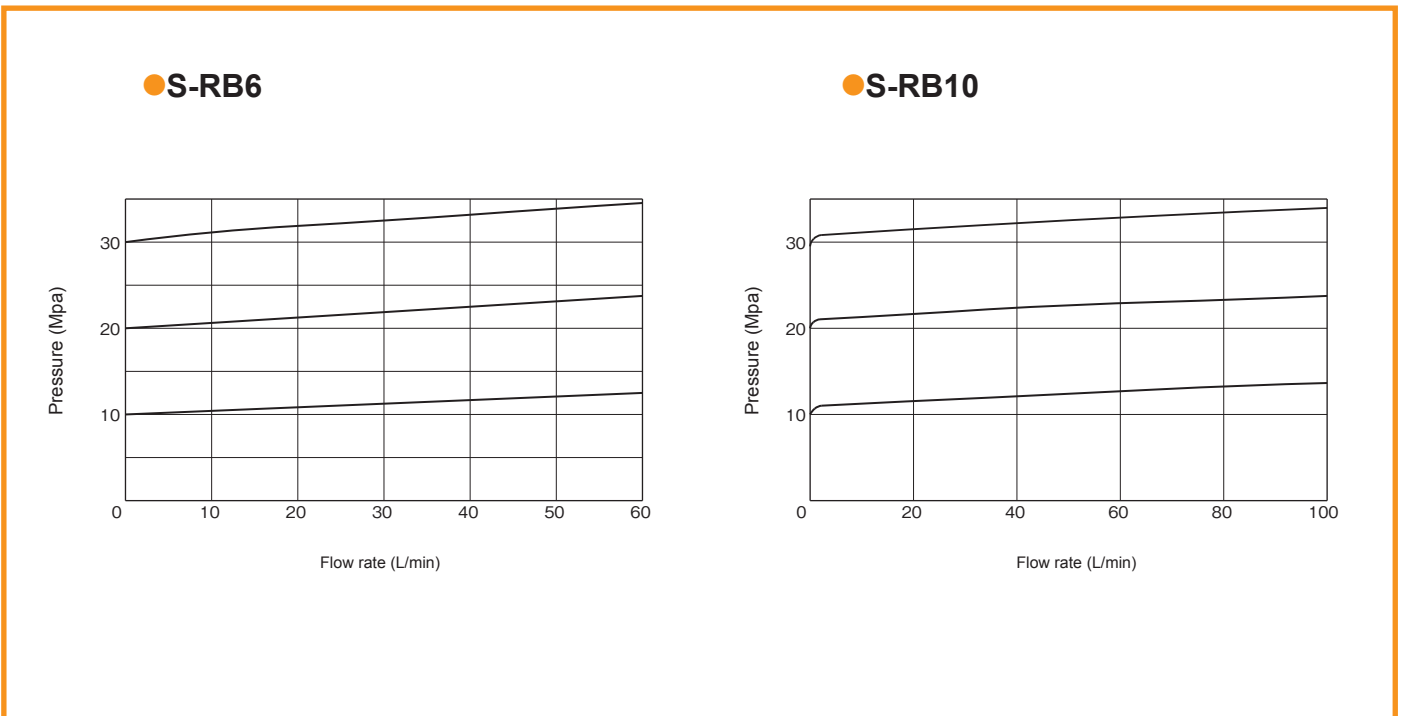

Dimension drawing

● S-(2)RB6

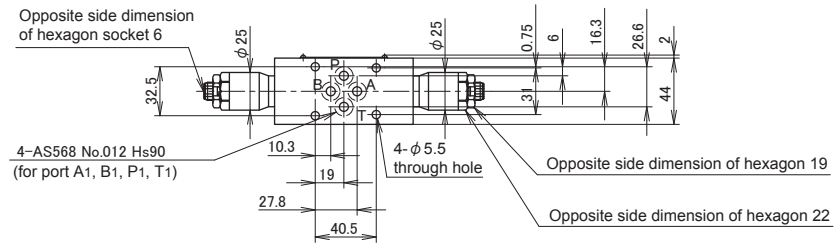

- In the case of S-RB6-10-A*

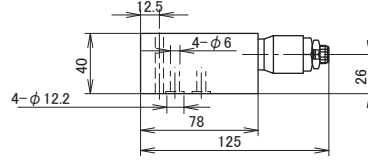

- In the case of S-RB6-10-B*
- In the case of S-RB6-10-P*

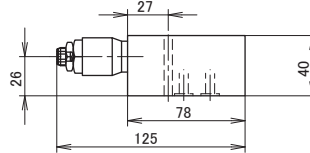

- In the case of S-2RB6-10-E*

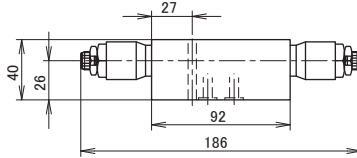

- In the case of S-2RB6-10-F*

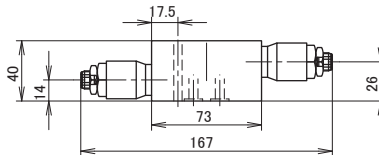

(Note) In the case of F, when the adjust screw of the relief valve on the A port side is adjusted, B port pressure can be adjusted. When the adjust screw of the relief valve on the B port side is adjusted, A port pressure can be adjusted.

● S-(2)RB10

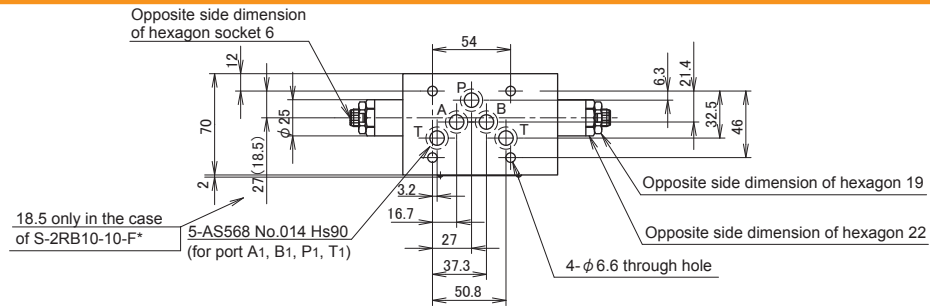

- In the case of S-RB10-10-A*
- In the case of S-RB10-10-P*

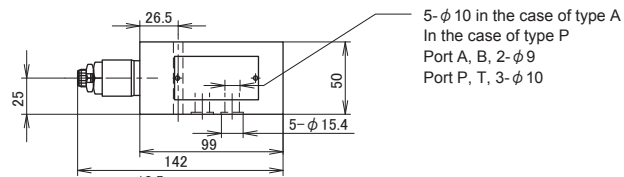

- In the case of S-RB10-10-B*

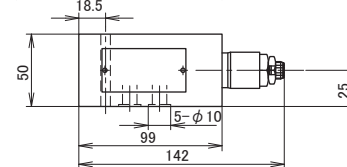

- In the case of S-2RB10-10-E*

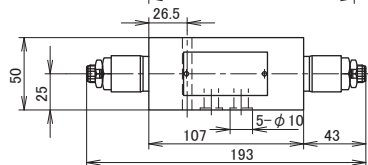

- In the case of S-2RB10-10-F*

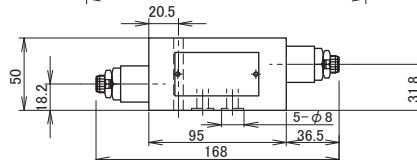

(Note) In the case of F, when the adjust screw of the relief valve on the A port side is adjusted, B port pressure can be adjusted. When the adjust screw of the relief valve on the B port side is adjusted, A port pressure can be adjusted.

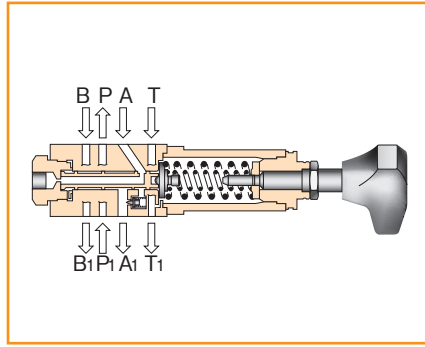
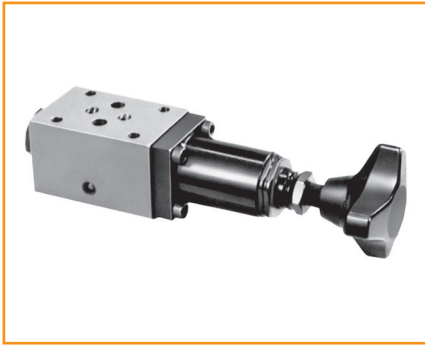

Type indication

S - SD 6 - 10 - P 1 / 25 Y C -

Sandwich type

SD = Sequence valve

CBD = Counterbalance valve

Nominal dimension

SD = 6, 10

CBD = 6

Series number: 10

Sequence valve incorporated port

A = Port A (CBDs have A only)

P = Port P

Shape of pressure adjusting part

1 = Handle adjustment

2 = Thread adjustment (with cap)

3 = Handle with key adjustment

Type of hydraulic oil

No symbol = Mineral based hydraulic oil

V = Phosphate ester based hydraulic oil

W = Fatty ester based hydraulic oil

Water-glycol based hydraulic oil

Types with/without check valve

No symbol = Without check valve

C = Types with a check valve

Pilot, Drain system

Y = Internal pilot and external drain

Pressure adjustment range MPa (kgf/cm²)

Symbol	Nominal dimension	
	6	10
25	0 to 2.5 (0 to 25)	0.2 to 2.5 (2 to 25)
75	0 to 7.4 (0 to 75)	0.4 to 7.4 (4 to 75)
150	2.9 to 14.7 (30 to 150)	1.0 to 14.7 (10 to 150)
210	3.4 to 20.6 (35 to 210)	1.0 to 20.6 (10 to 210)

Hydraulic symbols

● S-SD6-10-A*/*Y

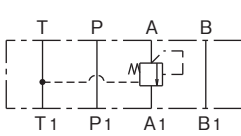

● S-SD6-10-A*/*YC

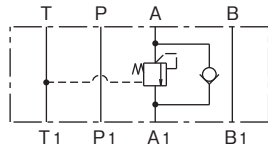

● S-SD6-10-P*/*Y

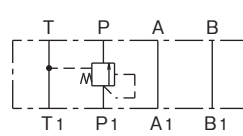

● S-CBD6-10-A*/*Y

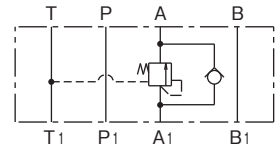

● S-SD10-10-A*/*Y

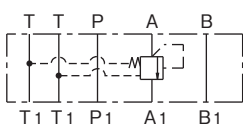

● S-SD10-10-A*/*YC

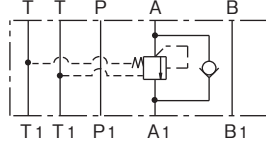

● S-SD10-10-P*/*Y

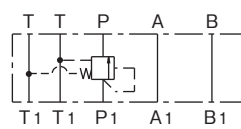

(Note) P1, A1, B1 and T1 show ports on the sub-plate side while P, A, B and T show ports on the selector valve side.

Specifications

Nominal dimension		6	10
Maximum working pressure MPa (kgf/cm ²)	Primary side	20.6 (210) (Note)	
	Secondary side	20.6 (210)	
	Back pressure (Port T)	5.9 (60)	1.5 (15)
Maximum flow rate L/min		30	50
Mass kg		1.2	3.1

(Note) Pressure adjustment range: When 150 is adjusted to 12.3 to 14.7 MPa (125 to 150 kgf/cm²), the maximum working pressure becomes 16.7 MPa (170 kgf/cm²).

● Pressure increase value per turn (clockwise) of adjust thread MPa (kgf/cm²)

Nominal dimension	6	10
Highest adjustment pressure		
25	0.3 (3.1)	0.29 (3.0)
75	0.87 (8.9)	0.86 (8.8)
150	1.51 (15.4)	1.72 (17.6)
210	2.05 (20.9)	2.4 (24.5)

● Mounting bolt

Type	Hexagon socket head cap thread	Quantity	Tightening torque N·m (kgf·cm ²)
S-SD6	M5×85L	4 pcs.	6.4±0.5 (65± 5)
S-CBD6	M5×85L	4 pcs.	
S-SD10	M6×85L	4 pcs.	13 ±1 (133±10)

When the solenoid valve is 10 Series, mounting bolts are as shown in the table below.

Type	Hexagon socket head cap thread	Quantity	Tightening torque N·m (kgf·cm ²)
S-SD6	M5×90L	4 pcs.	7.4±0.5 (75± 5)
S-CBD6	M5×90L	4 pcs.	
S-SD10	M6×100L	4 pcs.	11.8±1.7 (120±18)

Pressure override characteristics/Lowest adjustment pressure/Pressure drop characteristics

- Similar to those of the sequence valve - direct operated type.

Refer to the section of the type number index "SD6, 10".

Dimension drawing

● S-SD6-10-P

● Handle with key adjusting type

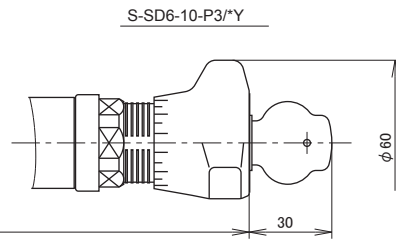

● Screw adjusting type

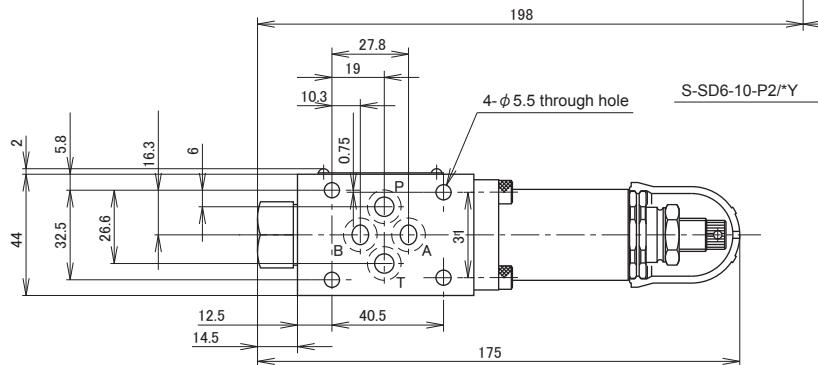

● Handle adjusting type

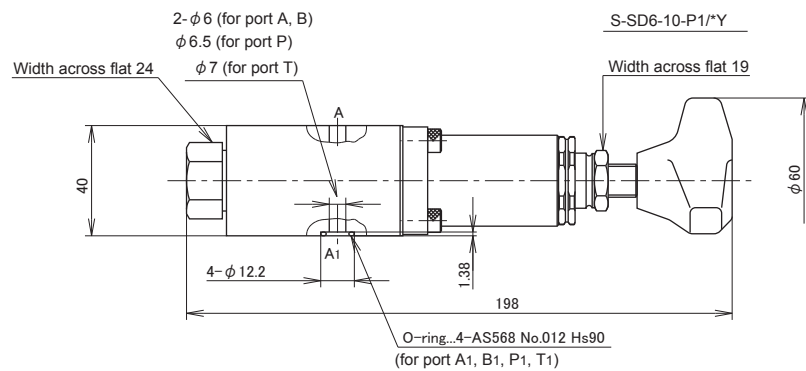

● S-CBD6-10-A

● S-SD6-10-A

● Handle with key adjusting type

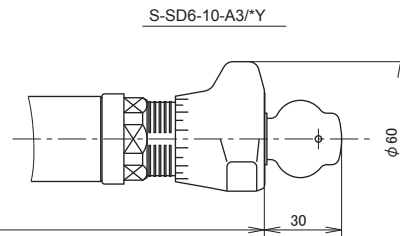

● Screw adjusting type

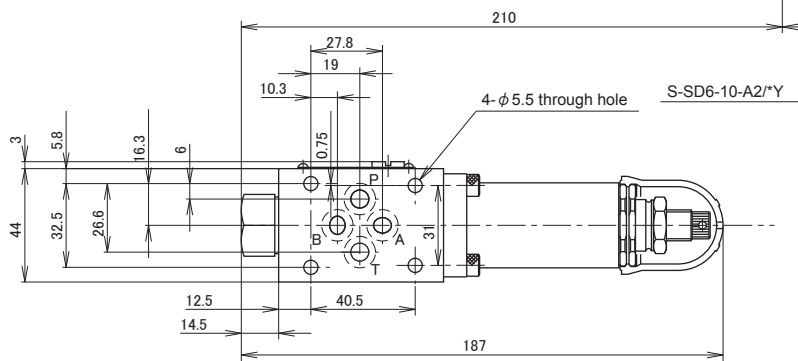

● Handle adjusting type

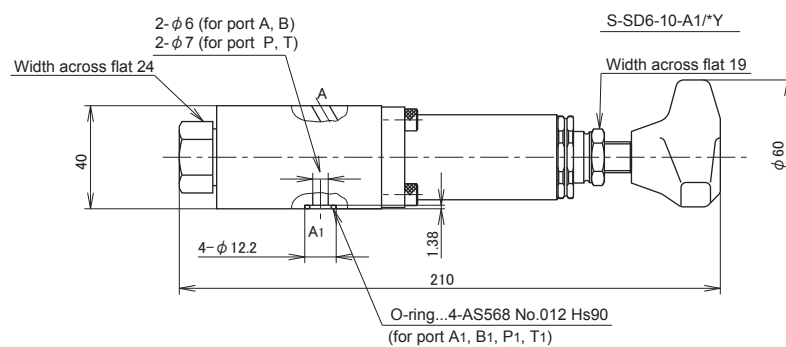

● S-SD10-10-P

● Handle with key adjusting type

● Screw adjusting type

● Handle adjusting type

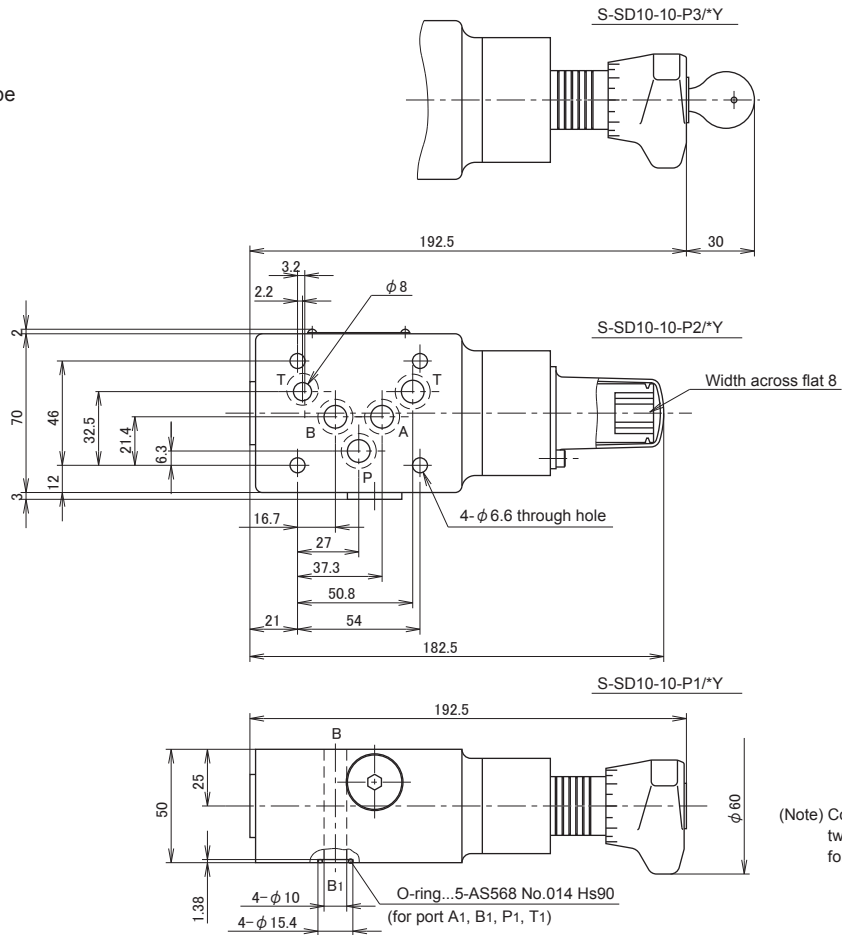

● S-SD10-10-A

● Handle with key adjusting type

● Screw adjusting type

● Handle adjusting type

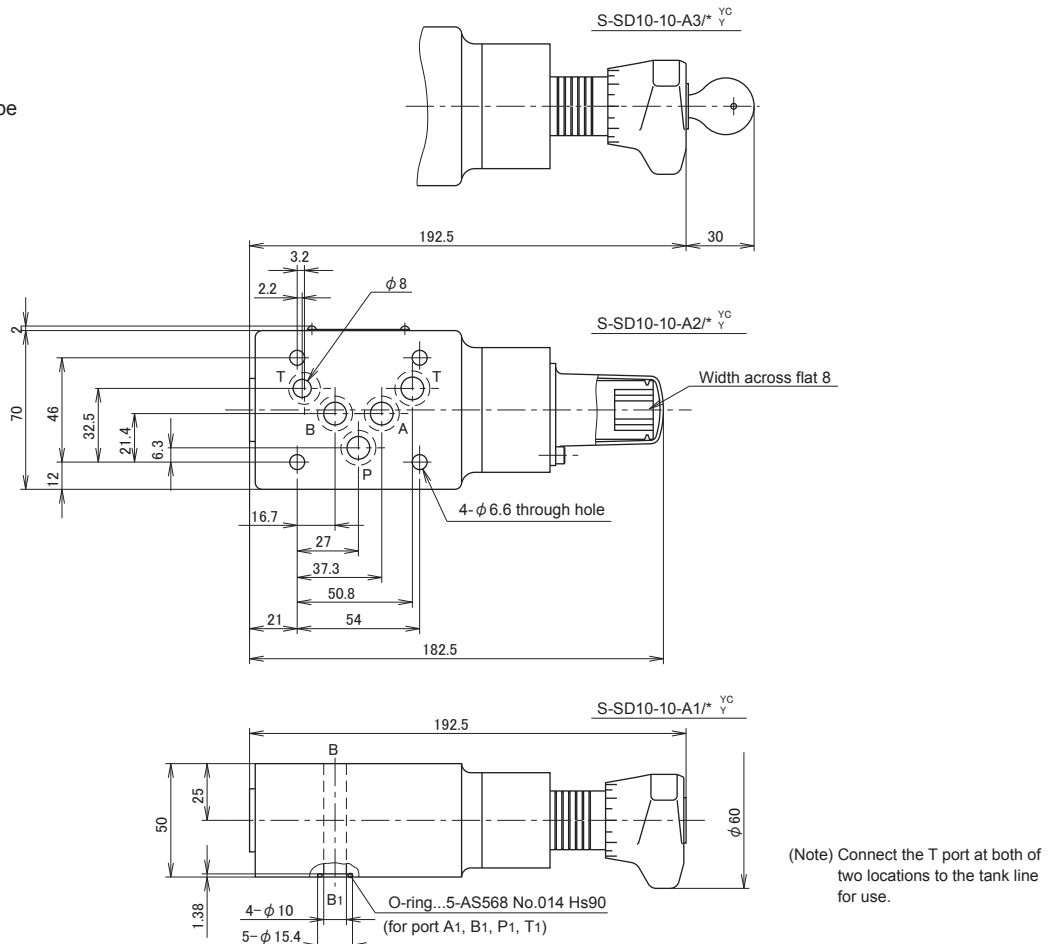

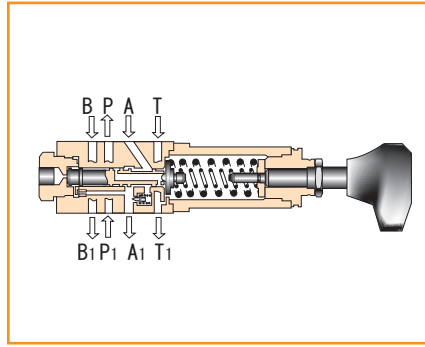
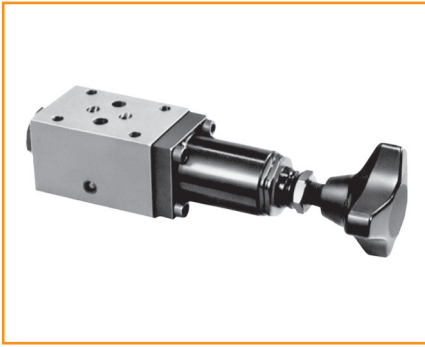

Type indication

S - PRD6 - 10 - P1 / 25YC -

Sandwich type

Pressure reducing valve

Nominal dimension

Series number: 10

Pressure reducing valve incorporated port

A = Port A

P = Port P

Shape of pressure adjusting part

1 = Handle adjustment

2 = Thread adjustment (with cap)

3 = Handle with key adjustment

Type of hydraulic oil

No symbol = Mineral based hydraulic oil

V = Phosphate ester based hydraulic oil

W = Fatty ester based hydraulic oil

Water-glycol based hydraulic oil

Types with/without check valve

No symbol = Without check valve

C = Types with a check valve

(This applies in case where the reducing valve is installed in the port A only)

Pilot, Drain system

Y = Internal pilot and external drain

Pressure adjustment range MPa (kgf/cm²)

Symbol	Nominal dimension	
	6	10
25	0.5 to 2.5 (5 to 25)	0.5 to 2.5 (5 to 25)
75	2.0 to 7.4 (20 to 75)	1.0 to 7.4 (10 to 75)
150	6.4 to 14.7 (65 to 150)	2.0 to 14.7 (20 to 150)
210	7.9 to 20.6 (80 to 210)	2.0 to 20.6 (20 to 210)

Hydraulic symbols

● S-PRD6-10-A*/*YC

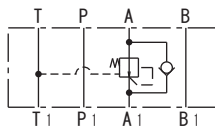

● S-PRD6-10-A*/*Y

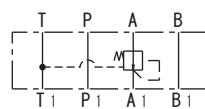

● S-PRD6-10-P*/*Y

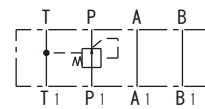

● S-PRD10-10-A*/*YC

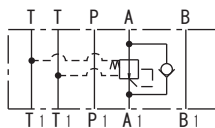

● S-PRD10-10-A*/*Y

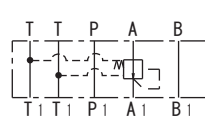

● S-PRD10-10-P*/*Y

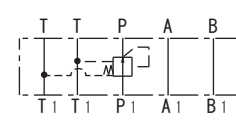

(Note) P1, A1, B1 and T1 show ports on the sub-plate side while P, A, B and T show ports on the selector valve side.

Specifications

Nominal dimension		6	10
Maximum working pressure MPa (kgf/cm ²)	Primary side	30.9 (315)	
	Secondary side	20.6 (210)	
	Back pressure Port T (Y)	5.9 (60)	1.5 (15)
Maximum flow rate L/min		30	45
Mass kg		1.2	3.1

● Pressure increase value per turn (clockwise) of adjust thread MPa (kgf/cm²)

Nominal dimension \ Highest adjustment pressure	6	10
25	0.3 (3.1)	0.29 (3.0)
75	0.87 (8.9)	0.86 (8.8)
150	1.51 (15.4)	1.72 (17.6)
210	2.05 (20.9)	2.4 (24.5)

● Mounting bolt

Type	Hexagon socket head cap thread	Quantity	Tightening torque N·m (kgf·cm ²)
S-PRD6	M5×85L	4 pcs.	6.4±0.5 (65± 5)
S-PRD10	M6×85L	4 pcs.	13 ±1 (133±10)

When the solenoid valve is 10 Series, mounting bolts are as shown in the table below.

Type	Hexagon socket head cap thread	Quantity	Tightening torque N·m (kgf·cm ²)
S-PRD6	M5×90L	4 pcs.	7.4±0.5 (75± 5)
S-PRD10	M6×100L	4 pcs.	11.8 ±1.7 (120±18)

Pressure override characteristics/ Pressure drop characteristics

- Similar to those of pressure reducing valve - direct operated type. Refer to the section of the type number index "PRD6, 10".

Dimension drawing

● S-PRD6-10-P

- Handle with key adjusting type

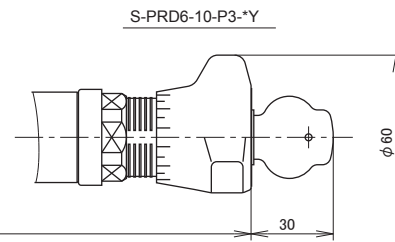

- Screw adjusting type

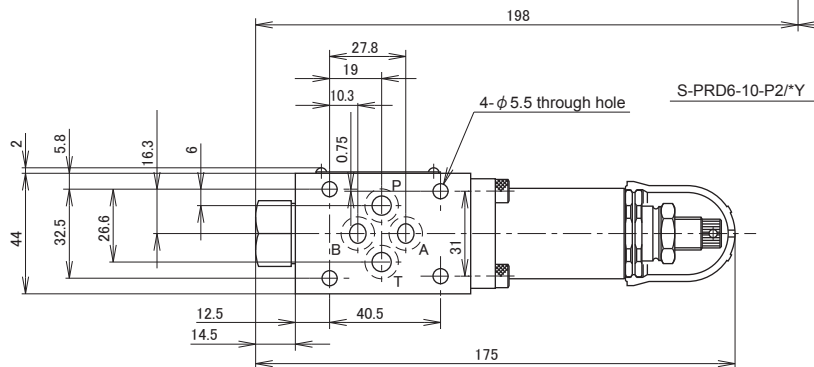

- Handle adjusting type

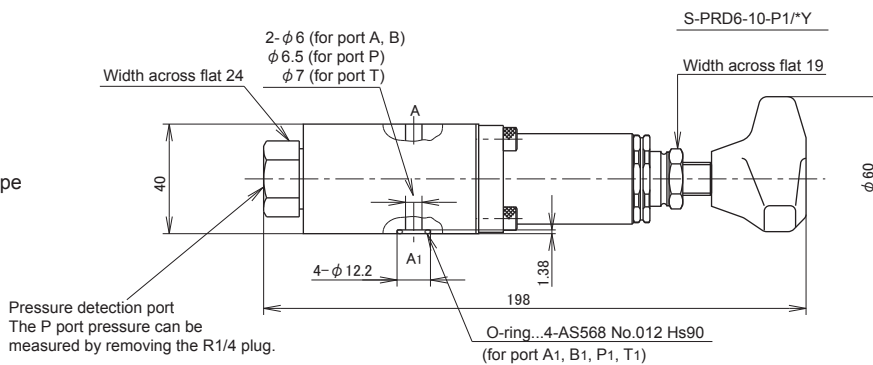

● S-PRD6-10-A

- Handle with key adjusting type

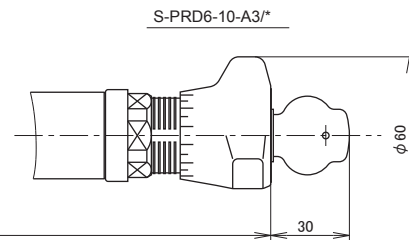

- Screw adjusting type

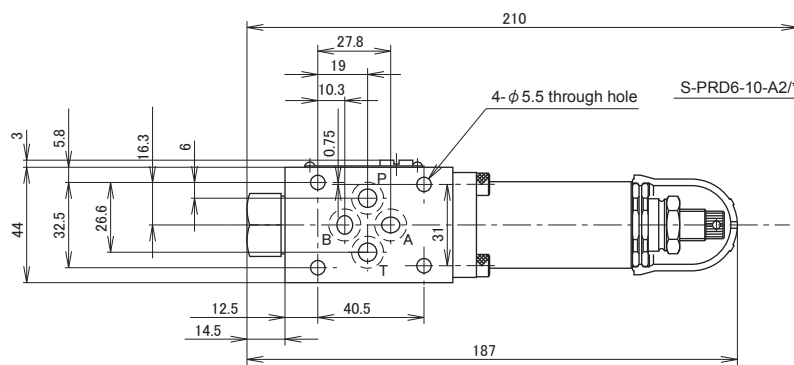

- Handle adjusting type

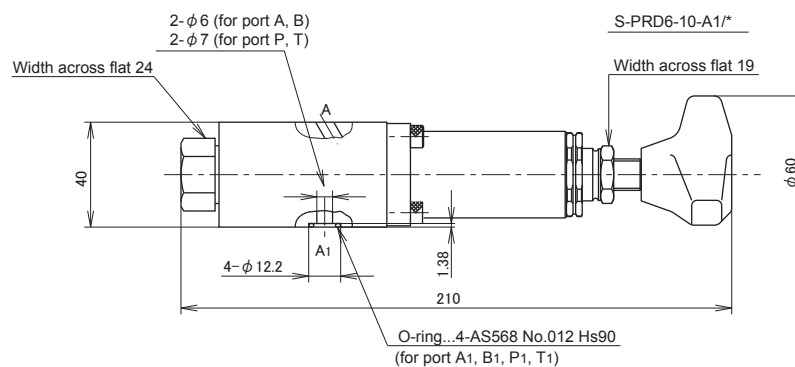

● S-PRD10-10-P

● Handle with key adjusting type

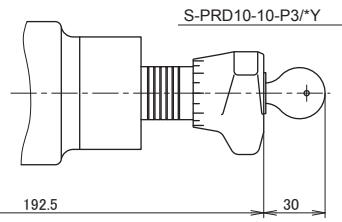

● Screw adjusting type

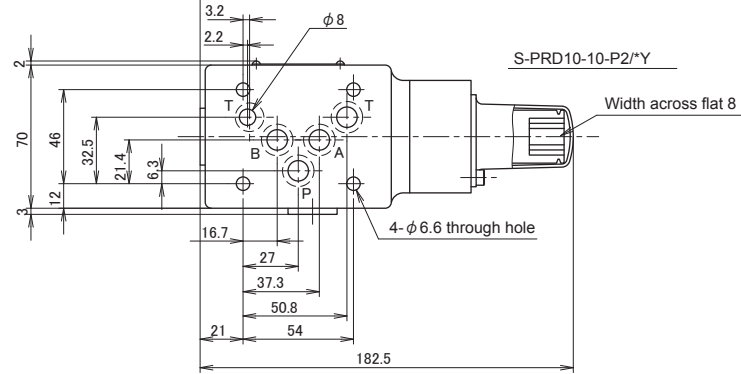

● Handle adjusting type

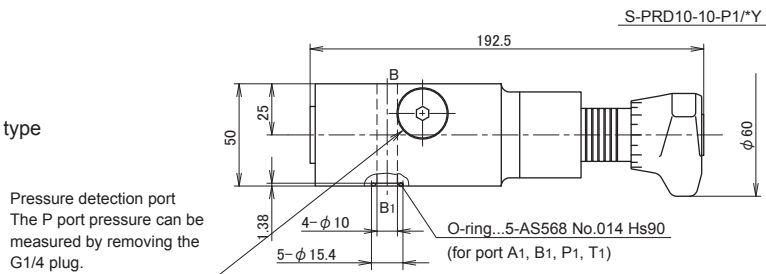

Pressure detection port
The P port pressure can be measured by removing the G1/4 plug.

(Note) Connect the T port at both of two locations to the tank line for use.

● S-PRD10-10-A

● Handle with key adjusting type

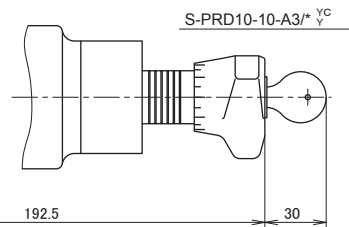

● Screw adjusting type

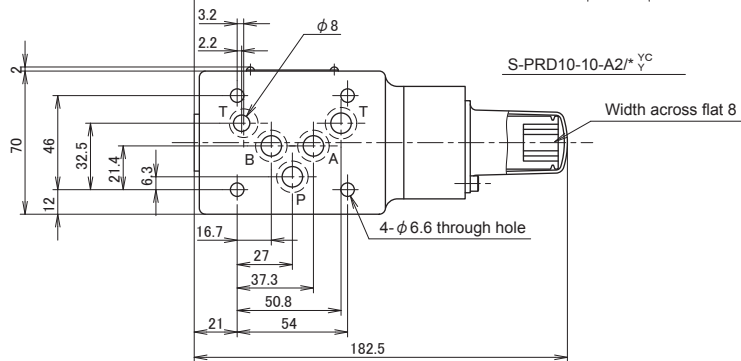

● Handle adjusting type

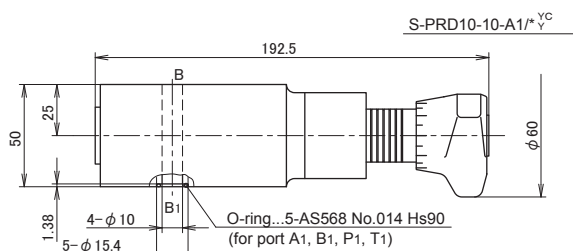

(Note) Connect the T port at both of two locations to the tank line for use.

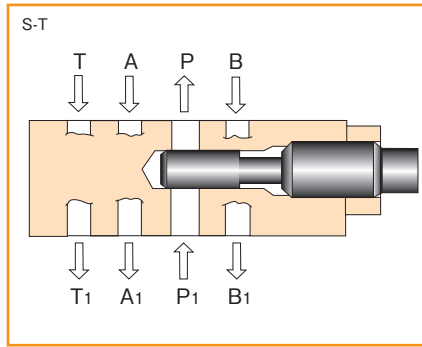
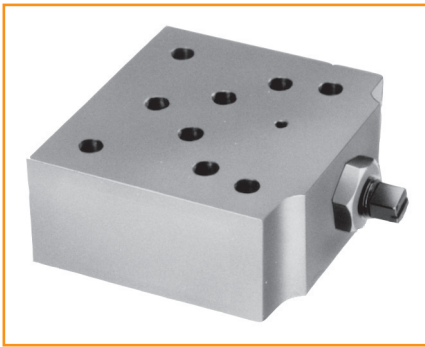

Type indication

S - T 6 - 10 - P 4 -

Sandwich type

Throttle valve

T = Single type
2T = Double type

Nominal dimension

6, 10

Series number: 10

Type of hydraulic oil

No symbol = Mineral based hydraulic oil
V = Phosphate ester based hydraulic oil
W = Fatty ester based hydraulic oil
Water-glycol based hydraulic oil

Shape of adjustment part

4 = Thread adjustment (without cap)

Throttle valve incorporated port symbol

	Symbol	Incorporated port
T	A	Port A
	B	Port B
	P	Port P
2T	E	Port A, B

Hydraulic symbols

● S-T6-10-P

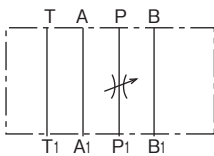

● S-T6-10-A

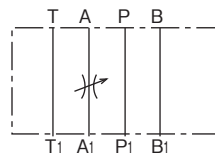

● S-T6-10-B

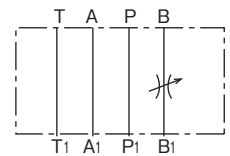

● S-T10-10-P

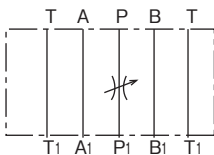

● S-T10-10-A

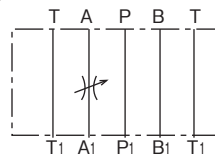

● S-2T6-10-E

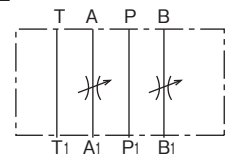

● S-T10-10-B

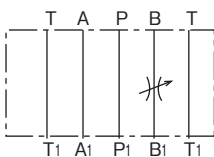

● S-2T10-10-E

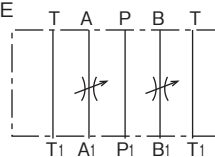

(Note) P1, A1, B1 and T1 show ports on the sub-plate side while P, A, B and T show ports on the selector valve side.

Specifications

Nominal dimension	6	10
Maximum working pressure MPa (kgf/cm ²)	30.9 (315)	
Maximum flow rate L/min	30	70
Mass kg	1.0	1.7

Mounting bolt

Type	Hexagon socket head cap thread	Quantity	Tightening torque N·m (kgf·cm ²)
S-(2)T6	M5×70L	4 pcs.	6.4±0.5 (5± 5)
S-(2)T10	M6×70L	4 pcs.	13 ±1 (133±10)

When the solenoid valve is 10 Series, mounting bolts are as shown in the table below.

Type	Hexagon socket head cap thread	Quantity	Tightening torque N·m (kgf·cm ²)
S-(2)T6	M5×75L	4 pcs.	7.4±0.5 (75± 5)
S-(2)T10	M6×85L	4 pcs.	11.8±1.7 (120±18)

Pressure drop characteristics (viscosity 36 mm²/s (cSt))

When the throttle valve is fully open

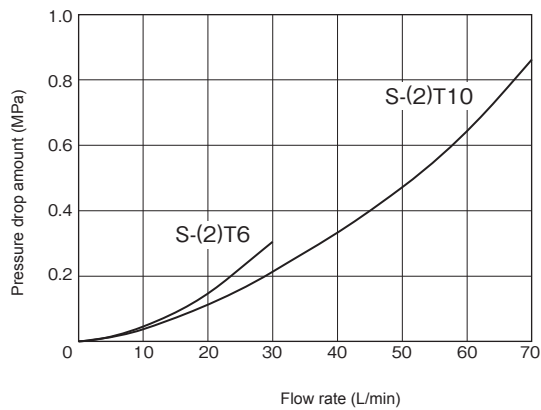

Dimension drawing

● S-T6-10-P

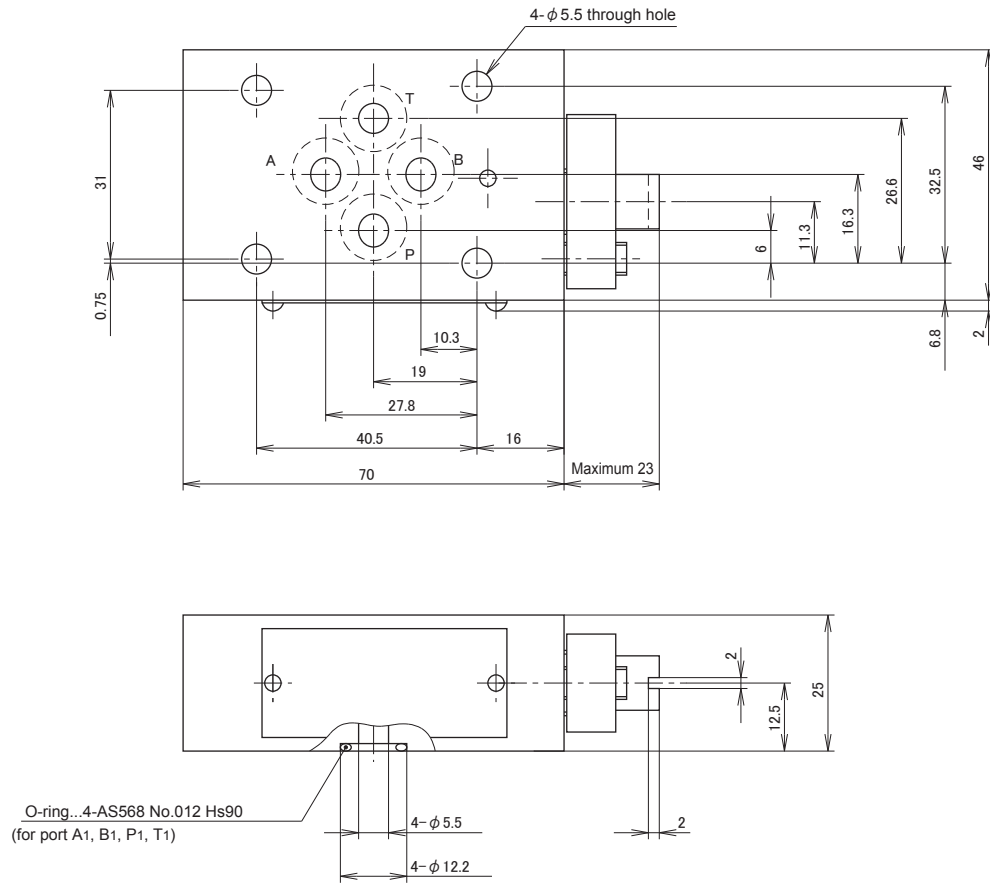

● S-T6-10-A

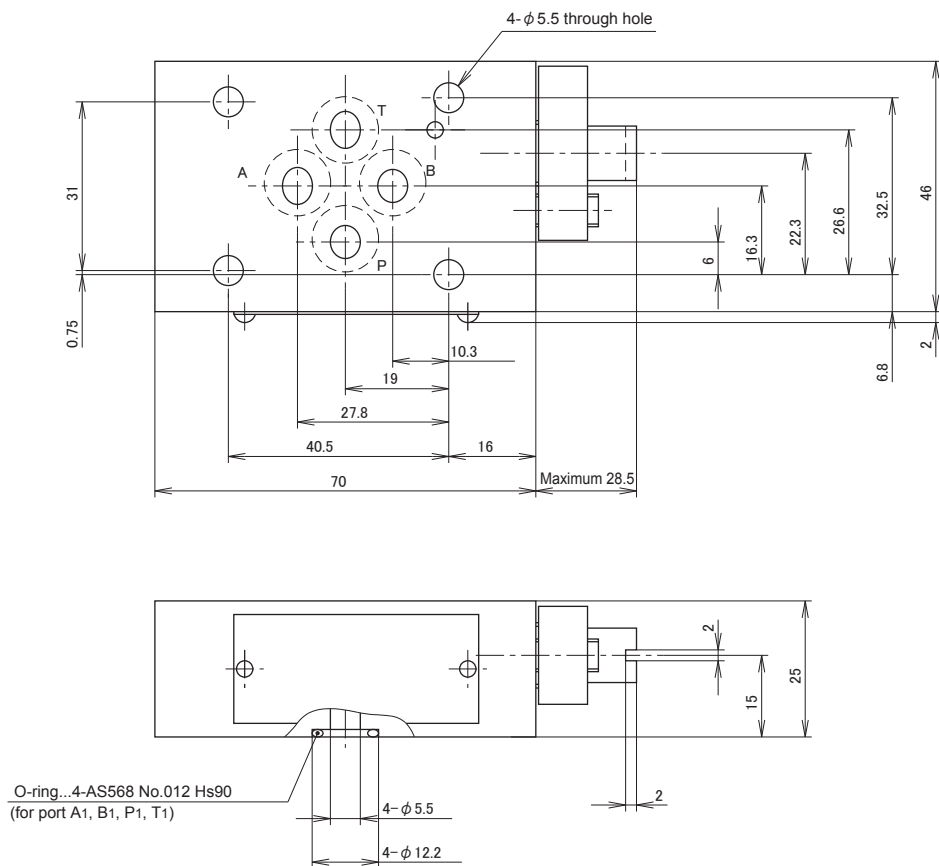

● S-T10-10-P

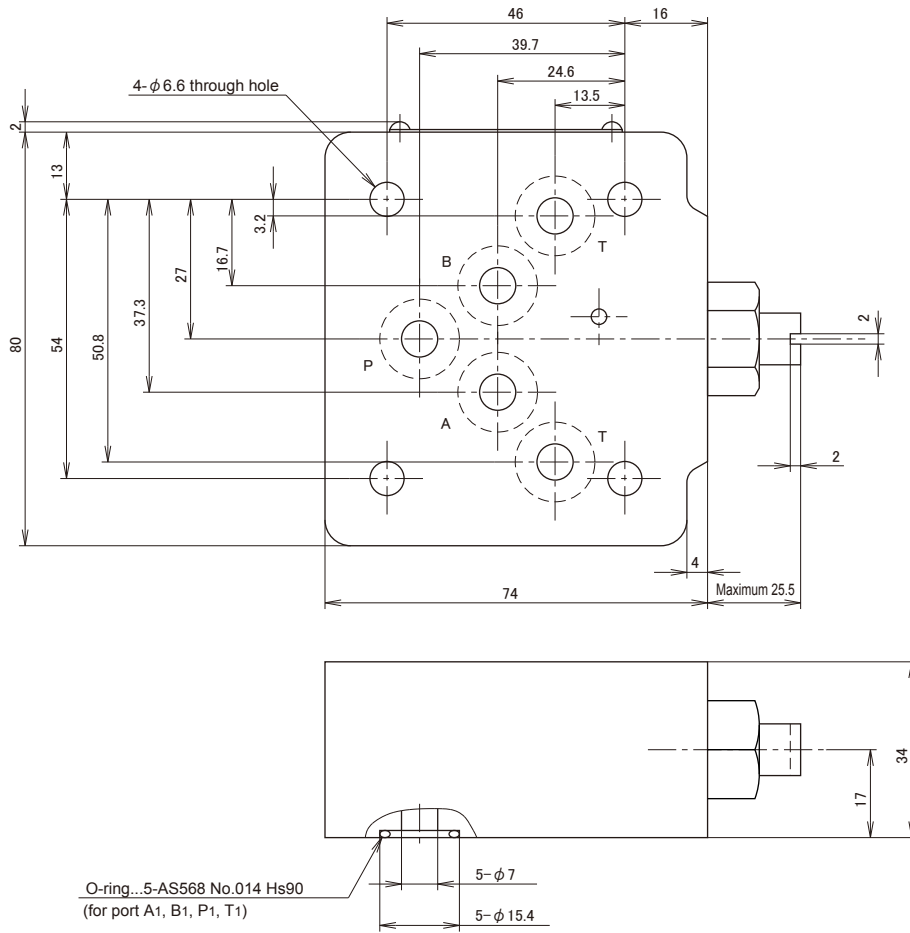

● S-T10-10-A

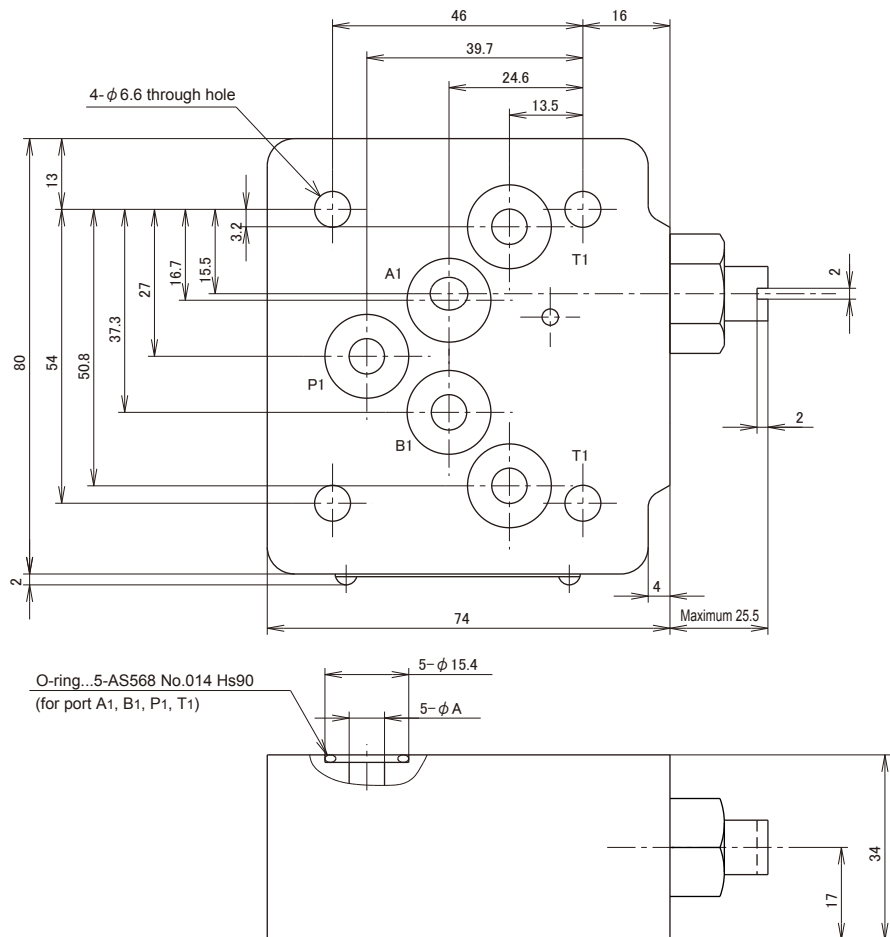

Dimension	ϕ A
Port A1	6
Port P1 B1, T1	6.5

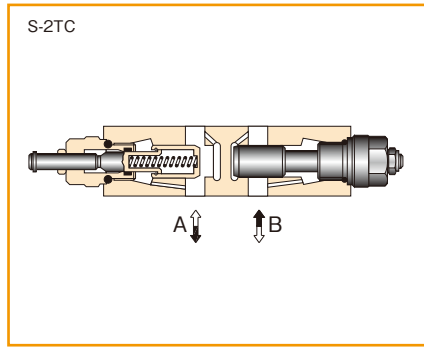
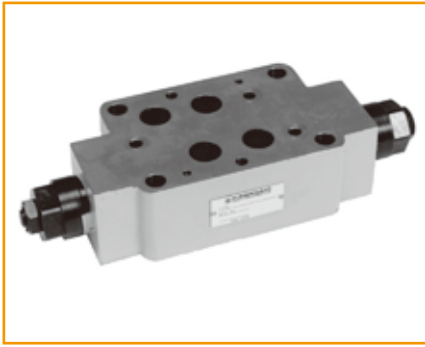

Type indication

● S-2TC6, 10

S - 2TC6 - 20 - E1 -

Sandwich type

Double slow return check valve

Nominal dimension
6, 10

Series number: 20

Type of hydraulic oil
No symbol = Mineral based hydraulic oil
Water-glycol based hydraulic oil
Phosphate ester based hydraulic oil
V = Fatty ester based hydraulic oil

Shape of adjustment part
1 = Handle adjustment

Throttle valve incorporated port symbol

Symbol	Incorporated port	Direction of controlled flow rate
E	Port A	A → A1 control (meter-in)
	Port B	B → B1 control (meter-in)
F	Port A	A1 → A control (meter-out)
	Port B	B1 → B control (meter-out)

● S-(2)TC16, 22

S - TC16 - 10 - A4 -

Sandwich type

Slow return check valve
TC = Single type
2TC = Double type

Nominal dimension
16, 22

Series number: 10

Type of hydraulic oil
No symbol = Mineral based hydraulic oil
V = Phosphate ester based hydraulic oil
W = Fatty ester based hydraulic oil
Water-glycol based hydraulic oil

Shape of adjustment part
4 = Thread adjustment (without cap)

Throttle valve incorporated port symbol

	Symbol	Incorporated port	Direction of controlled flow rate
TC	A	Port A	A → A1 control (meter-in)
	B	Port B	B → B1 control (meter-in)
	C	Port A	A1 → A control (meter-out)
	D	Port B	B1 → B control (meter-out)
2TC	E	Port A Port B	A → A1 control (meter-in) B → B1 control (meter-in)
	F	Port A Port B	A1 → A control (meter-out) B1 → B control (meter-out)

Hydraulic symbols

● S-2TC6-20-E

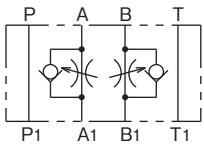

● S-2TC6-20-F

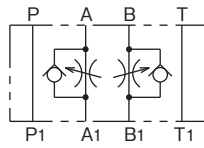

● S-2TC10-20-E

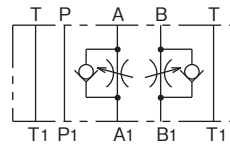

● S-2TC10-20-F

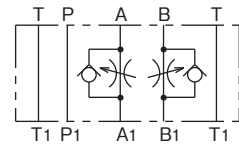

● S-TC¹⁶/₂₂-10-A

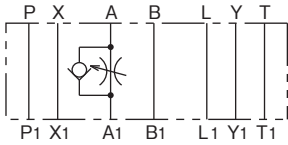

● S-TC¹⁶/₂₂-10-B

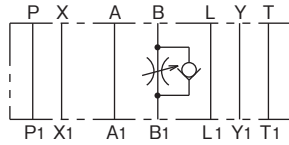

● S-TC¹⁶/₂₂-10-C

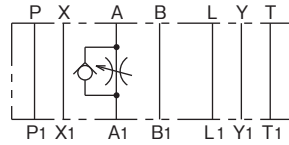

● S-TC¹⁶/₂₂-10-D

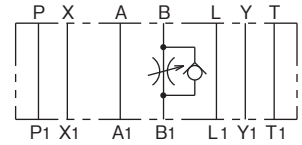

● S-2TC¹⁶/₂₂-10-E

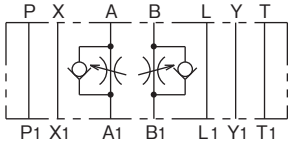

● S-2TC¹⁶/₂₂-10-F

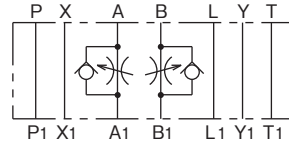

(Note) P1, A1, B1, T1, X1, Y1, and L1 show ports on the sub-plate side while P, A, B, T, X, Y and L show ports on the selector valve side.

Specifications

Nominal dimension	6	10	16	22
Maximum working pressure MPa (kgf/cm ²)	30.9 (315)		34.3 (350)	
Maximum flow rate L/min	60	120	250	350
Mass kg	1.5	3.7	4.5	7.5

Mounting bolt

Type	Hexagon socket head cap thread	Quantity	Tightening torque N·m (kgf·cm ²)
S-2TC6-20	M5 ×85L [*]	4 pcs.	6.4±0.5 (65± 5)
S-2TC10-20	M6 ×90L [*]	4 pcs.	13 ±1 (133± 10)
S-(2)TC16	M6 ×105L	2 pcs.	11.8±1.7 (120± 18)
	M10×110L	4 pcs.	56.8±8.5 (580± 87)
S-(2)TC22	M12×115L	6 pcs.	98.0±14.7 (1000±150)

*When the solenoid valve is 10 Series, mounting bolts are as shown in the table below.

Type	Hexagon socket head cap thread	Quantity	Tightening torque N·m (kgf·cm ²)
S-2TC6-20	M5 ×95L	4 pcs.	7.4±0.5 (75± 5)
S-2TC10-20	M6 ×105L	4 pcs.	11.8±1. (120± 18)

(Note) In the case of S-2TC6-10, S-2TC6-11 and S-2TC6-12, the mounting bolt becomes shorter by the difference of overall height of the valve (10 mm).
In the case of S-2TC10-10, S-2TC10-11 and S-2TC10-12, the mounting bolt becomes shorter by the difference of overall height of the valve (20 mm).

Opening - Flow rate characteristics (viscosity 36 mm²/s (cSt))

● S-2TC6

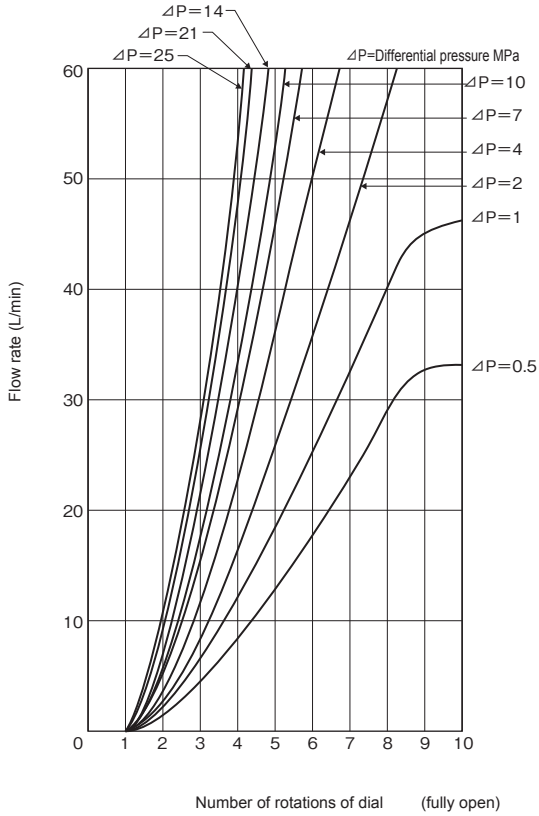

● S-2TC10

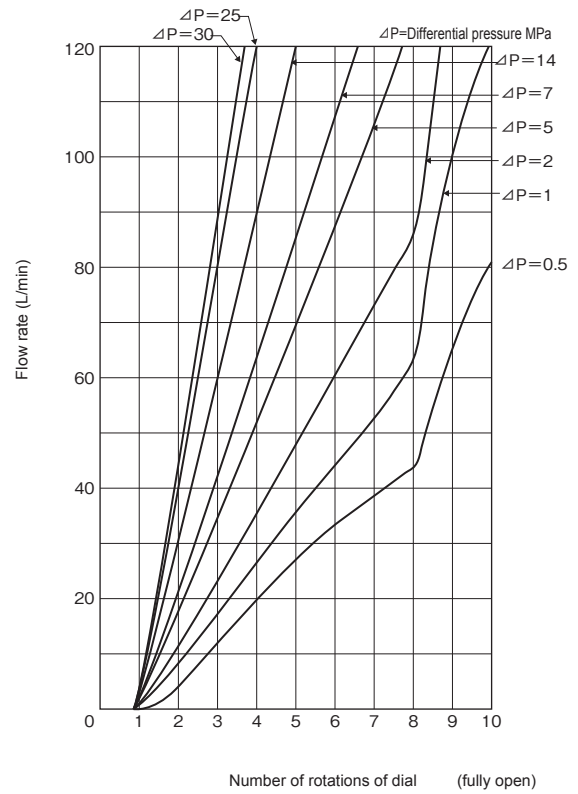

Pressure - Flow rate characteristics (viscosity 36 mm²/s (cSt))

● S-(2)TC16

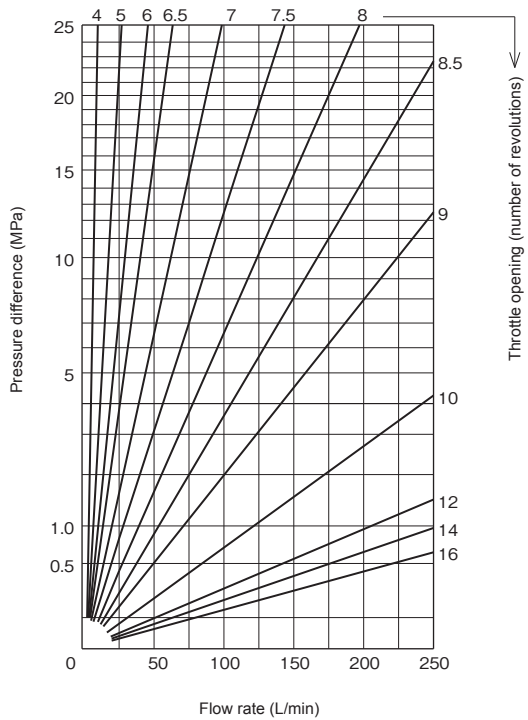

● S-(2)TC22

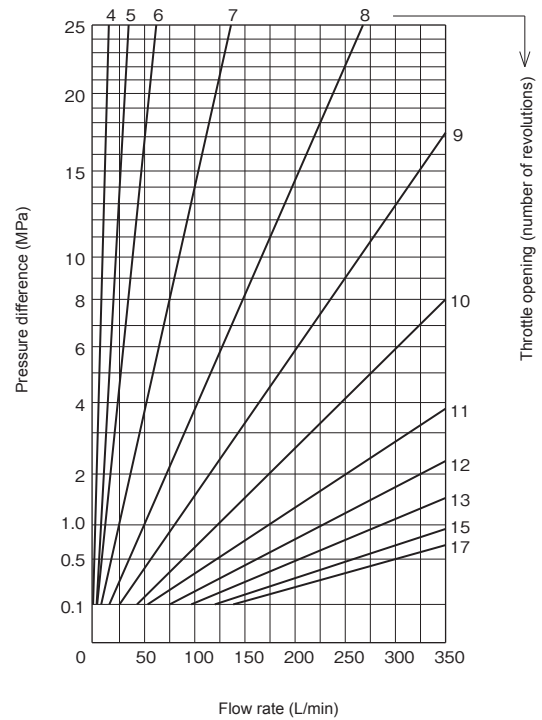

Pressure drop characteristics (viscosity 36 mm²/s (cSt))

● When the throttle valve is closed and the check valve is free flow

● S-2TC6

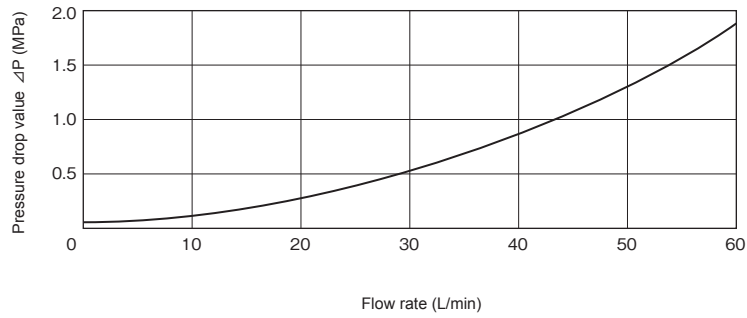

● S-2TC10

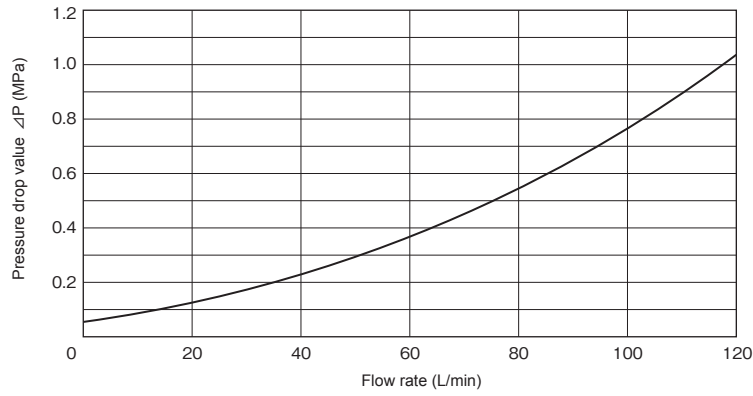

● S-(2)TC16

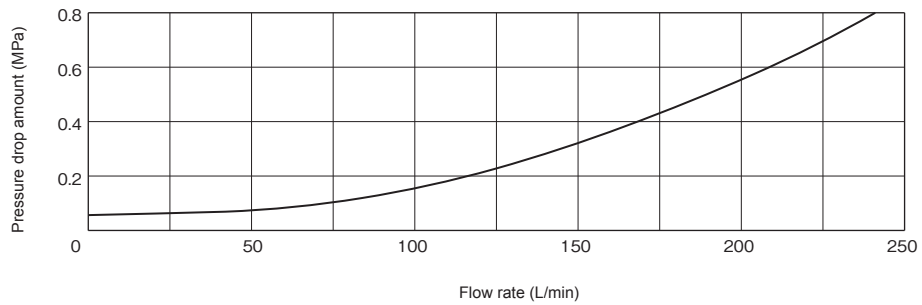

● S-(2)TC22

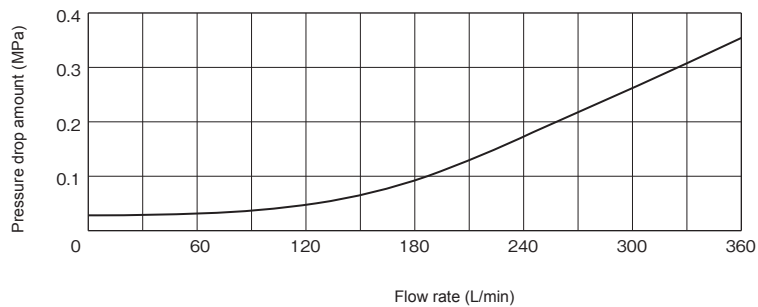

Dimension drawing

● S-2TC6

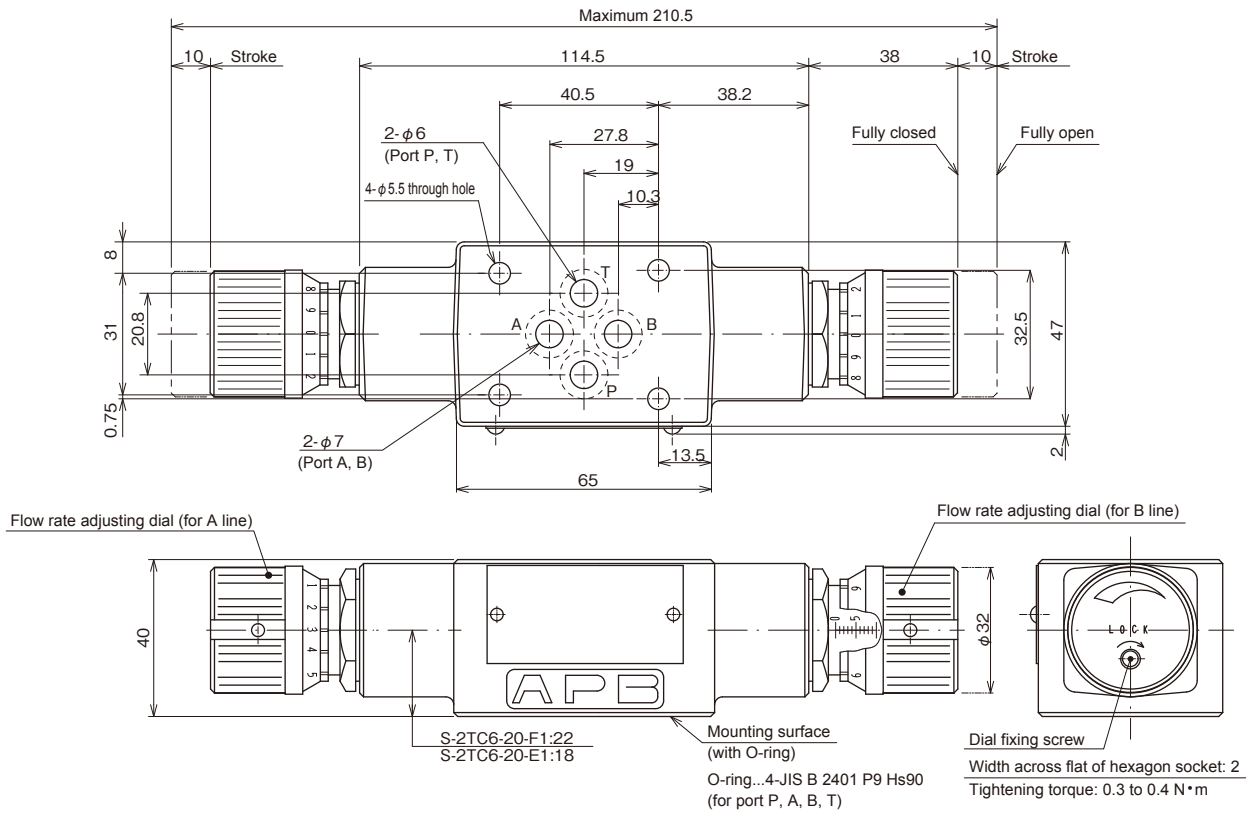

Method of adjusting flow rate

When the dial fixing screw is loosened and the flow rate adjusting dial is turned clockwise, the flow rate is restricted.
After adjustment, be sure to tighten the dial fixing screw.

● S-2TC10

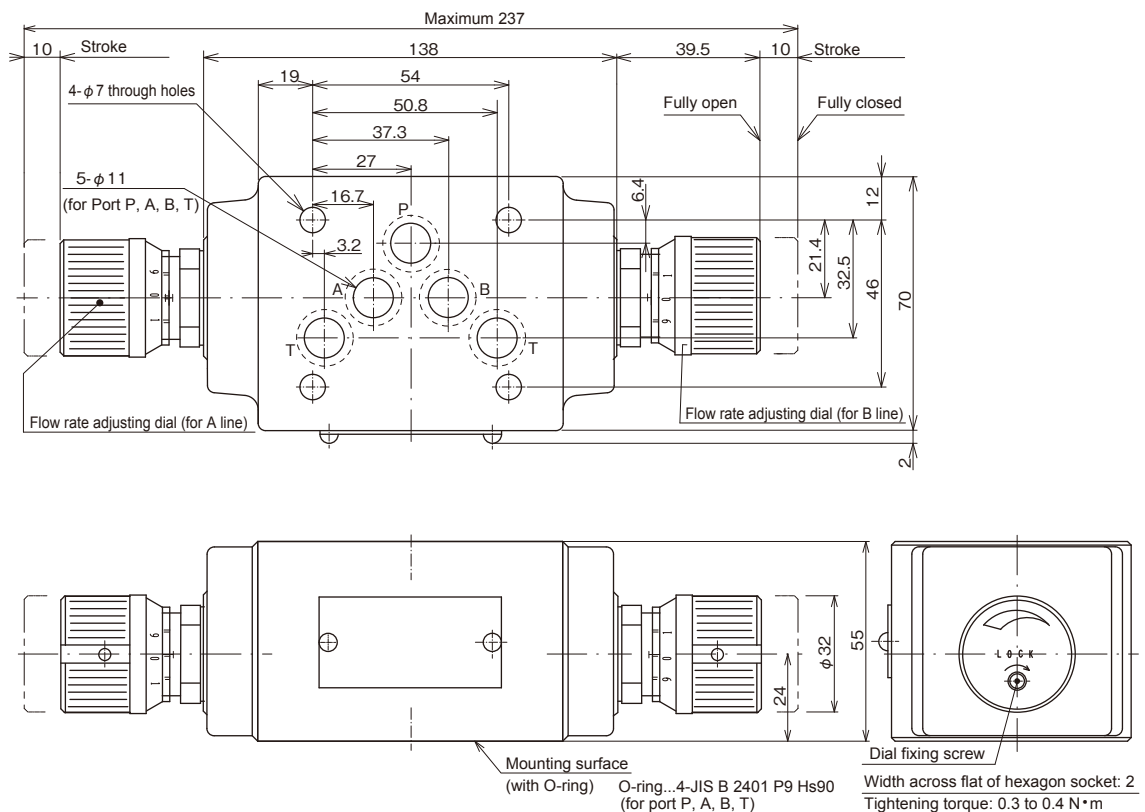

Method of adjusting flow rate

When the dial fixing screw is loosened and the flow rate adjusting dial is turned clockwise, the flow rate is restricted.
After adjustment, be sure to tighten the dial fixing screw.

●S-(2)TC16

●S-2TC16

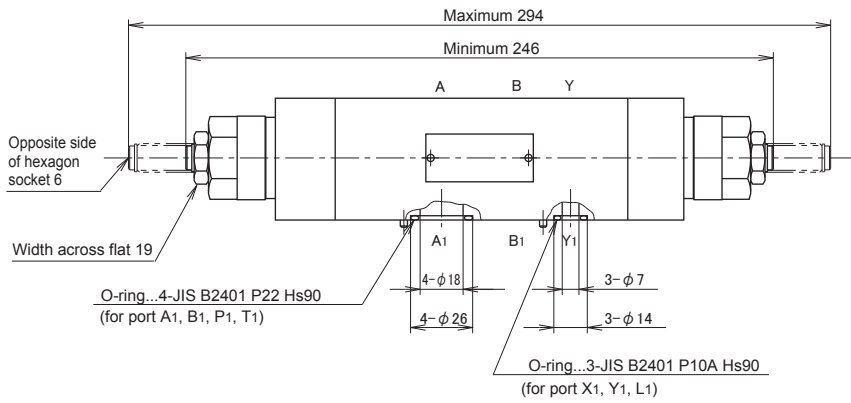
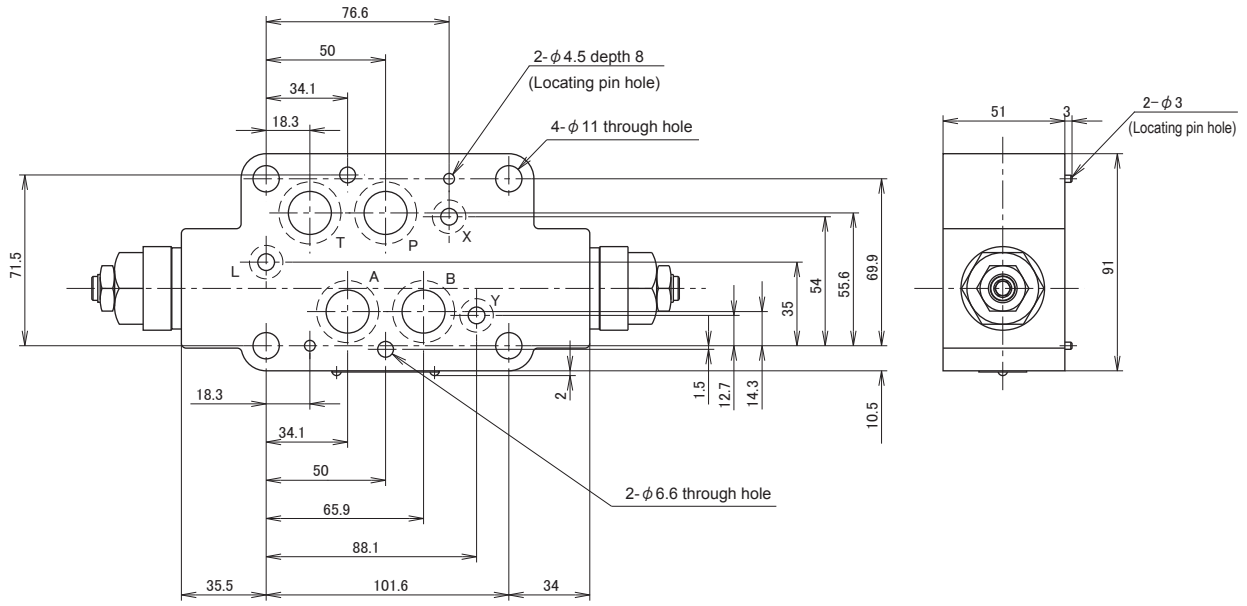

●S-TC16-10-A

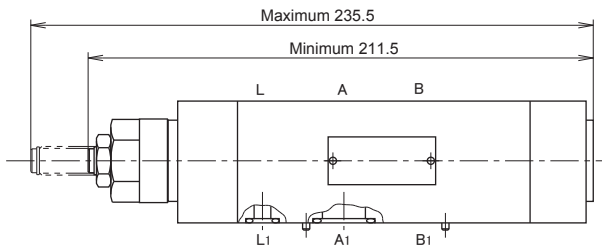

●S-TC16-10-B

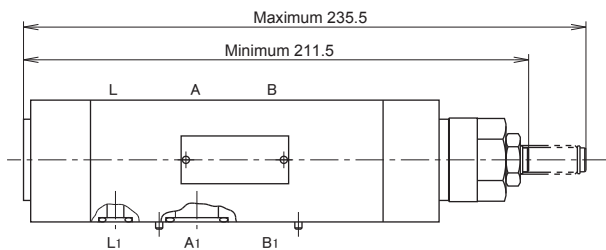

● S-(2)TC22

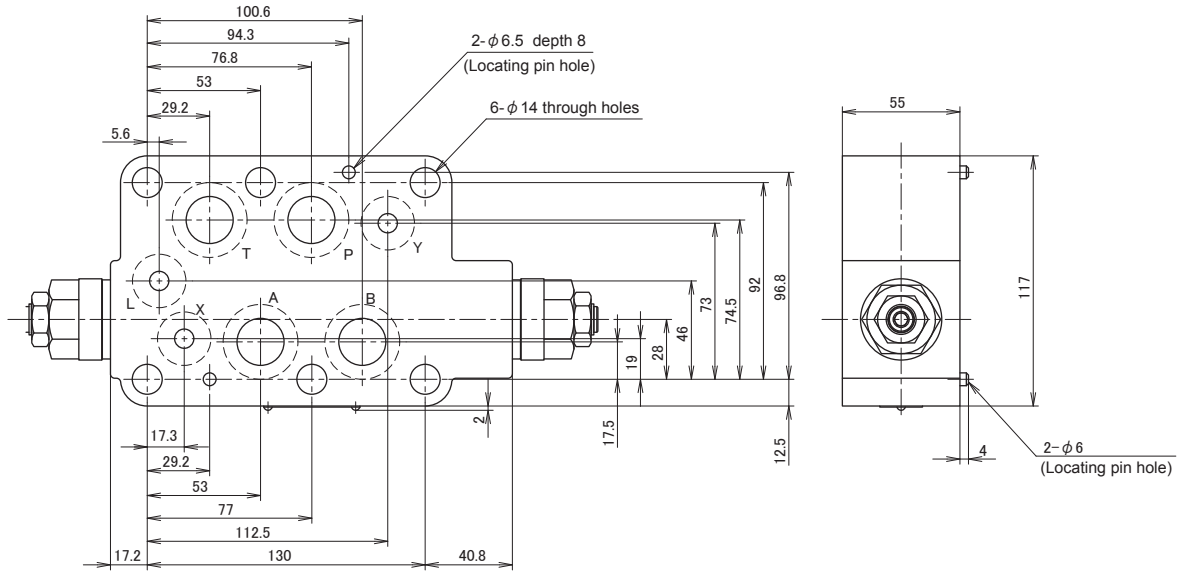

● S-2TC22

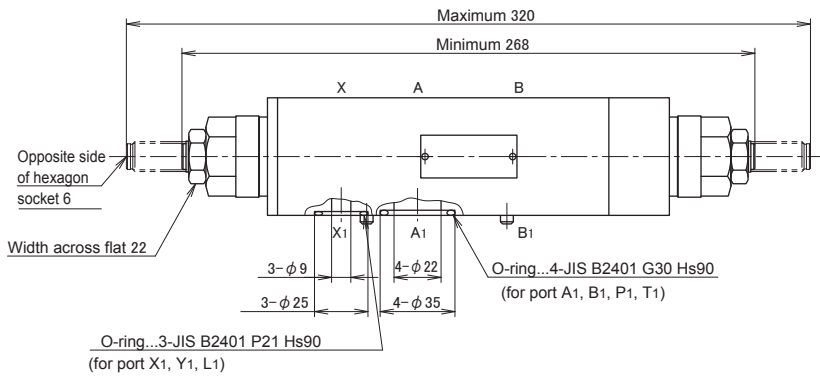

● S-TC22-10-A

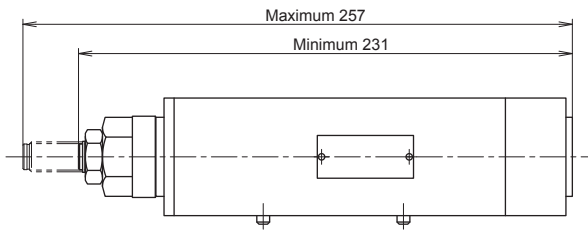

● S-TC22-10-B

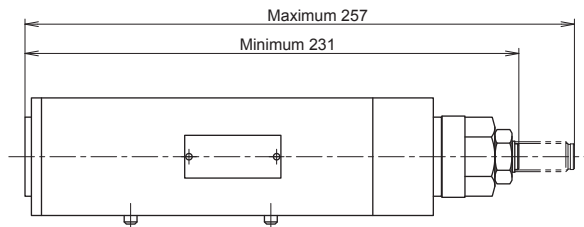

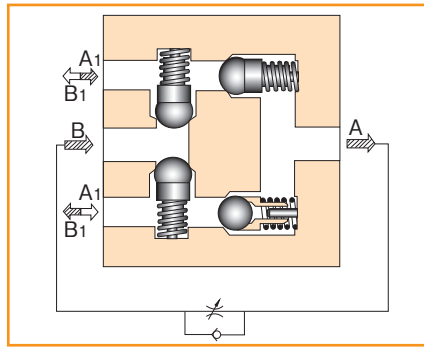
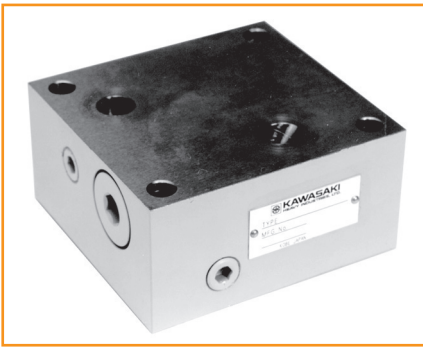

Type indication

S - 4C 5 - 10 - □

Sandwich type

Check valve block
(for flow regulating valve)

Nominal dimension
5, 10, 16

Type of hydraulic oil

- No symbol = Mineral based hydraulic oil
- V = Phosphate ester based hydraulic oil
- W = Fatty ester based hydraulic oil
- Water-glycol based hydraulic oil

Series number: 10

Hydraulic symbols

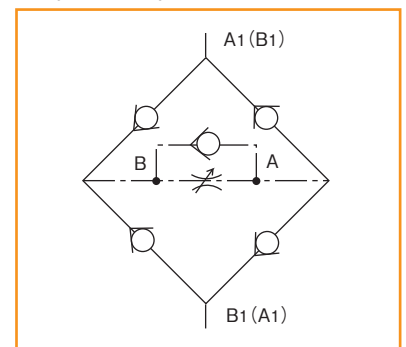

Specifications

Nominal dimension	5	10	16
Maximum working pressure MPa (kgf/cm ²)	30.9 (315)		
Maximum flow rate L/min	15	50	160
Cracking pressure MPa (kgf/cm ²)	0.1 (1.0)		
Mass kg	0.6	3.2	9.3

Mounting bolt

Type	Hexagon socket head cap thread	Quantity	Tightening torque N·m (kgf·cm ²)
S-4C 5	M5×80L	4 pcs.	6.9±1.0 (70±10)
S-4C 10	M8×100L	4 pcs.	29.4±4.4 (300±45)
S-4C 16	M10×165L	4 pcs.	56.8±8.5 (580±87)

Pressure drop characteristics (viscosity 36 mm²/s (cSt))

S-4C5

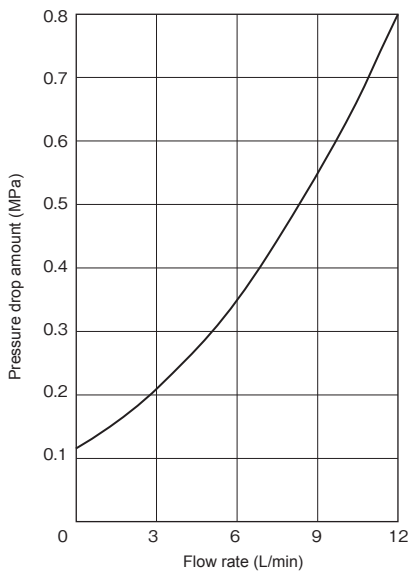

S-4C10

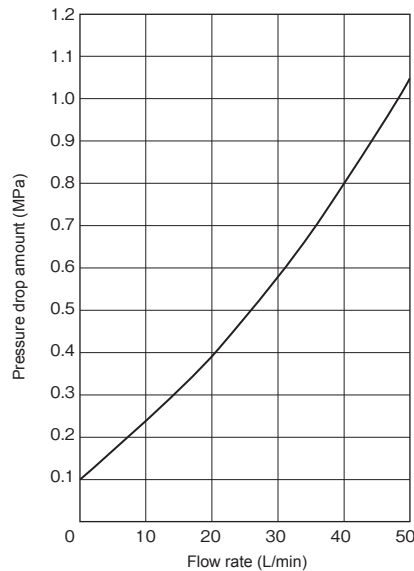

S-4C16

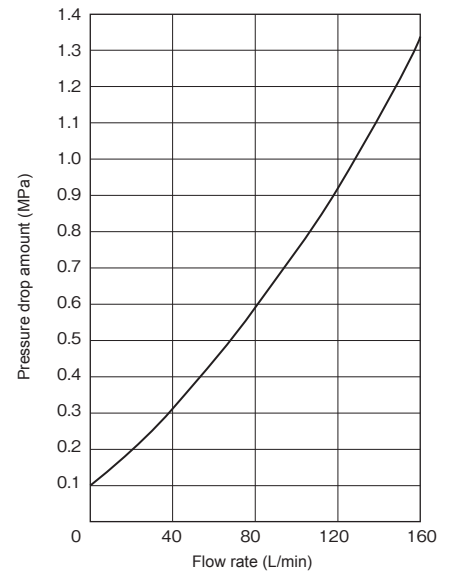

Dimension drawing

● S-4C5

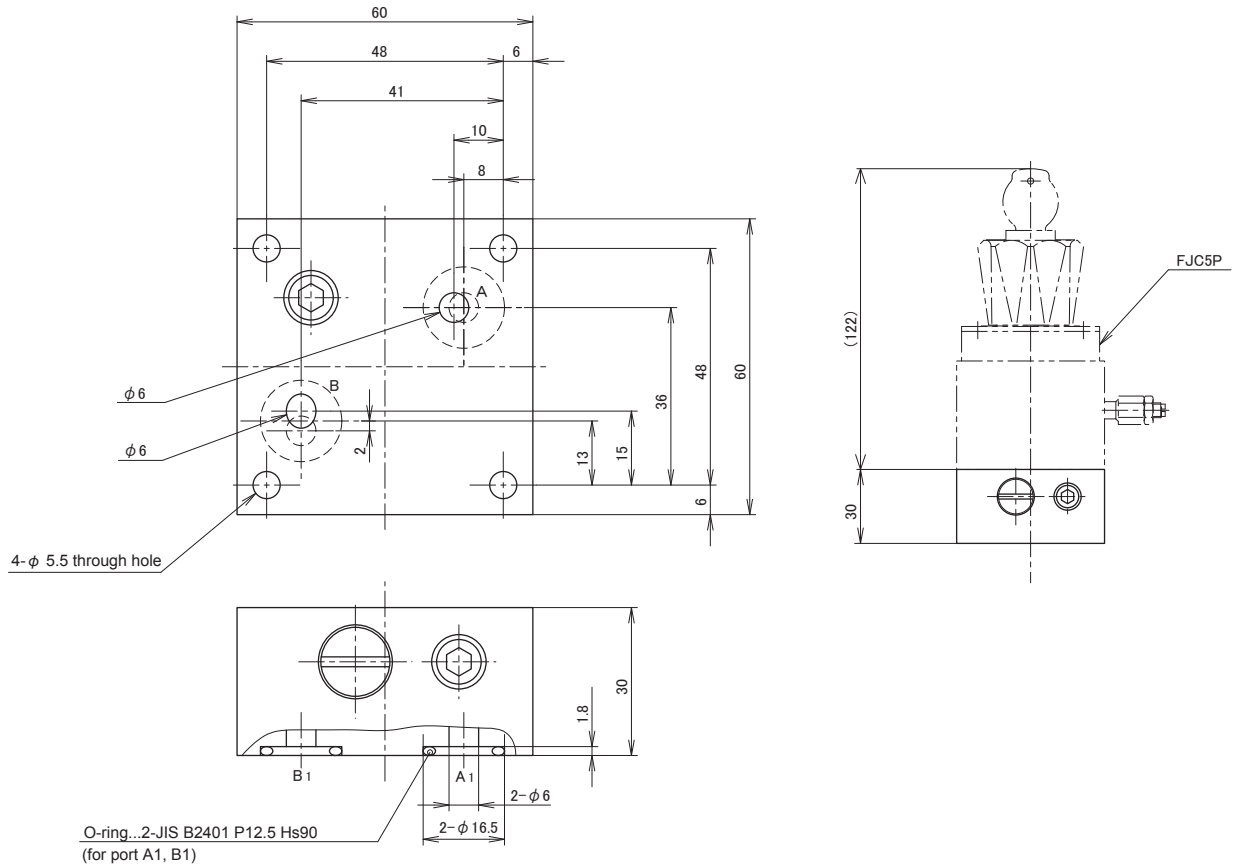

● S-4C10

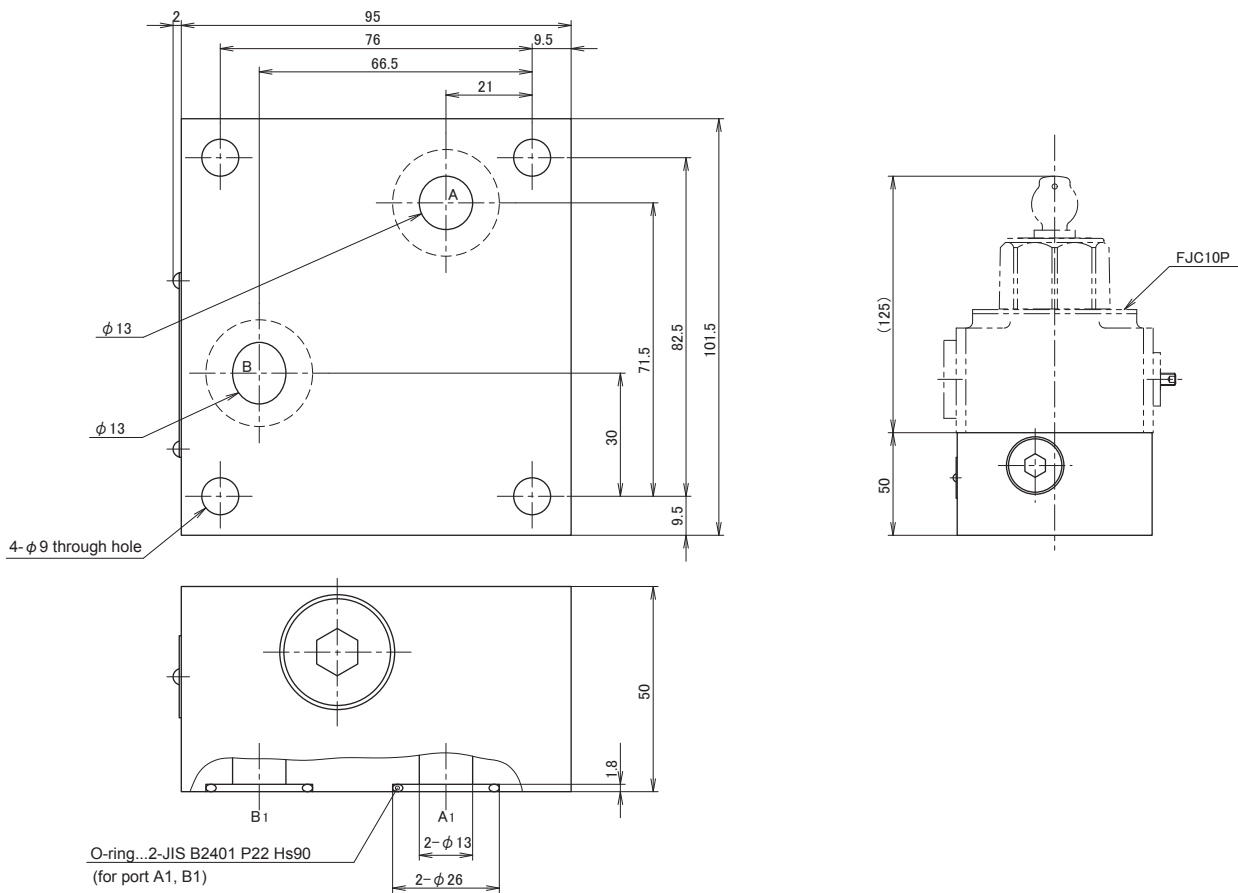

● S-4C16

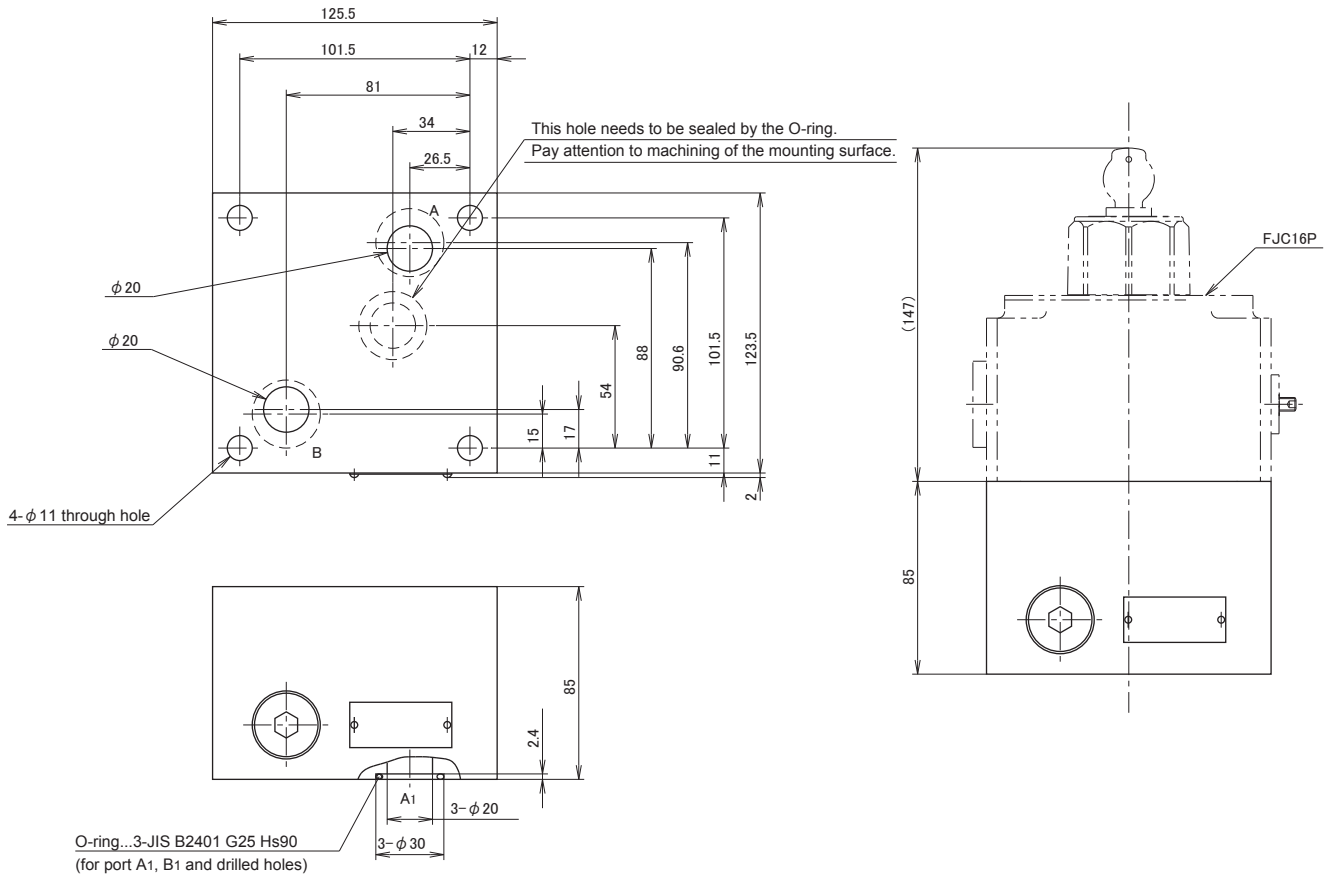

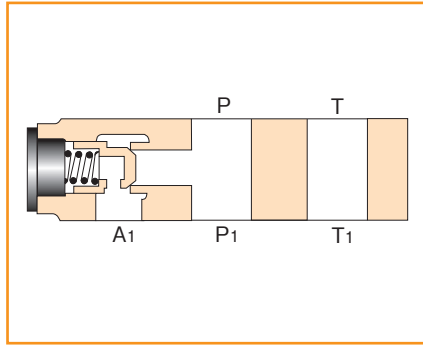

● Hydraulic symbols

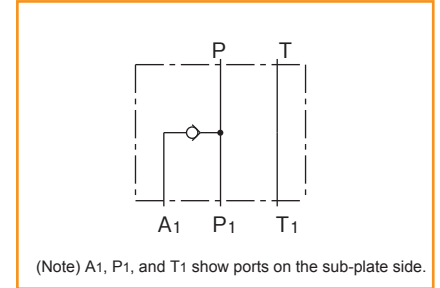

■ Type indication

ZA 20 - 10 - []

Sandwich type
check valve block

Nominal dimension

10, 20, 30

Type of hydraulic oil

No symbol = Mineral based hydraulic oil

V = Phosphate ester based hydraulic oil

W = Fatty ester based hydraulic oil

Water-glycol based hydraulic oil

Series number: Nominal dimension 10 = 11

Nominal dimension 20, 30 = 10

■ Specifications

Nominal dimension	10	20	30
Maximum working pressure MPa (kgf/cm ²)	30.9(315)		
Maximum flow rate L/min	120	400	600
Cracking pressure MPa (kgf/cm ²)	0.05(0.5)		
Mass kg	2.5	5.0	10.5

■ Accessories

● Mounting bolt

Type	Hexagon socket head cap thread	Quantity	Tightening torque N·m (kgf·cm ²)
ZA10	M12×85L	4 pcs.	98.0±14.7 (1000±150)
ZA20	M16×50L	2 pcs.	235.2±35.2 (2400±360)
	M16×95L	4 pcs.	
ZA30	M18×70L	2 pcs.	333.2±50.0 (3400±510)
	M18×120L	4 pcs.	

■ Pressure drop characteristics (viscosity 36 mm²/s (cSt))

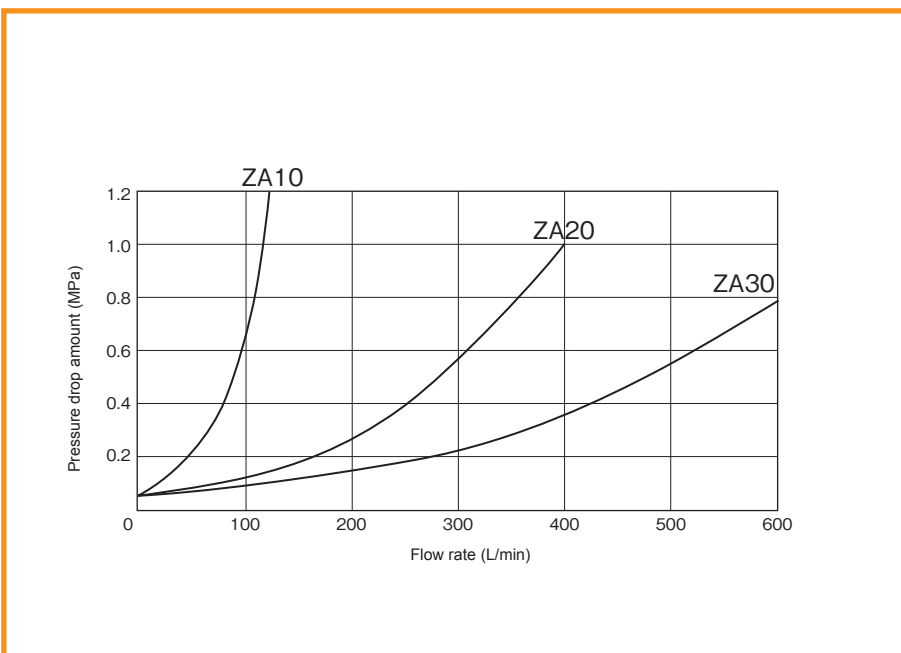

Dimension drawing

●ZA10

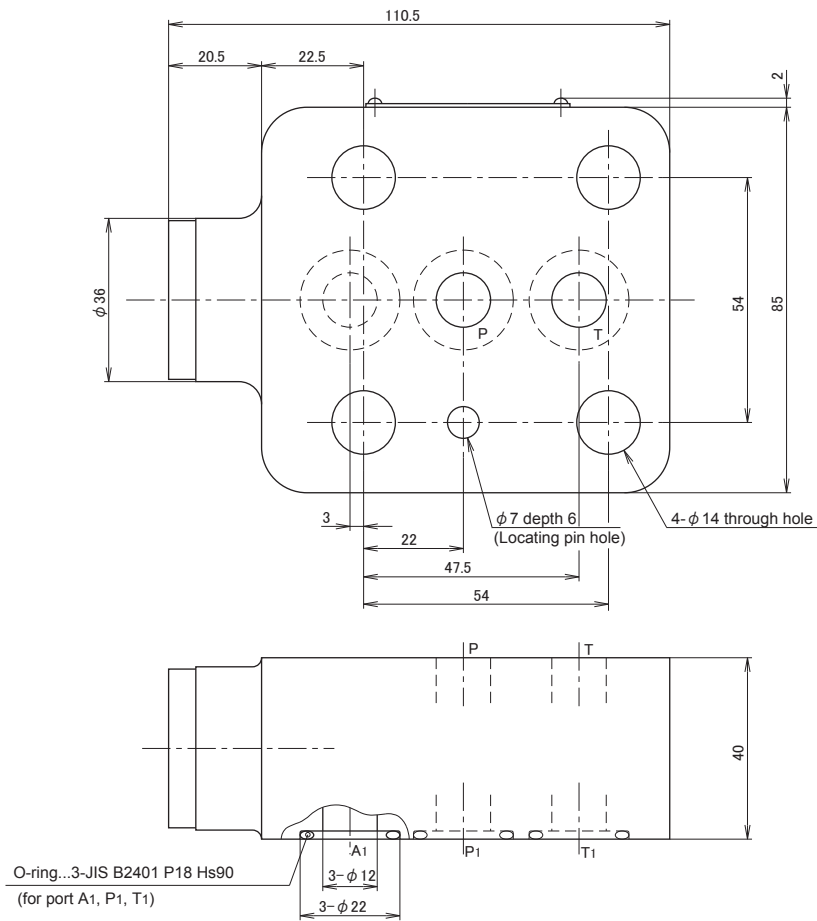

●ZA20

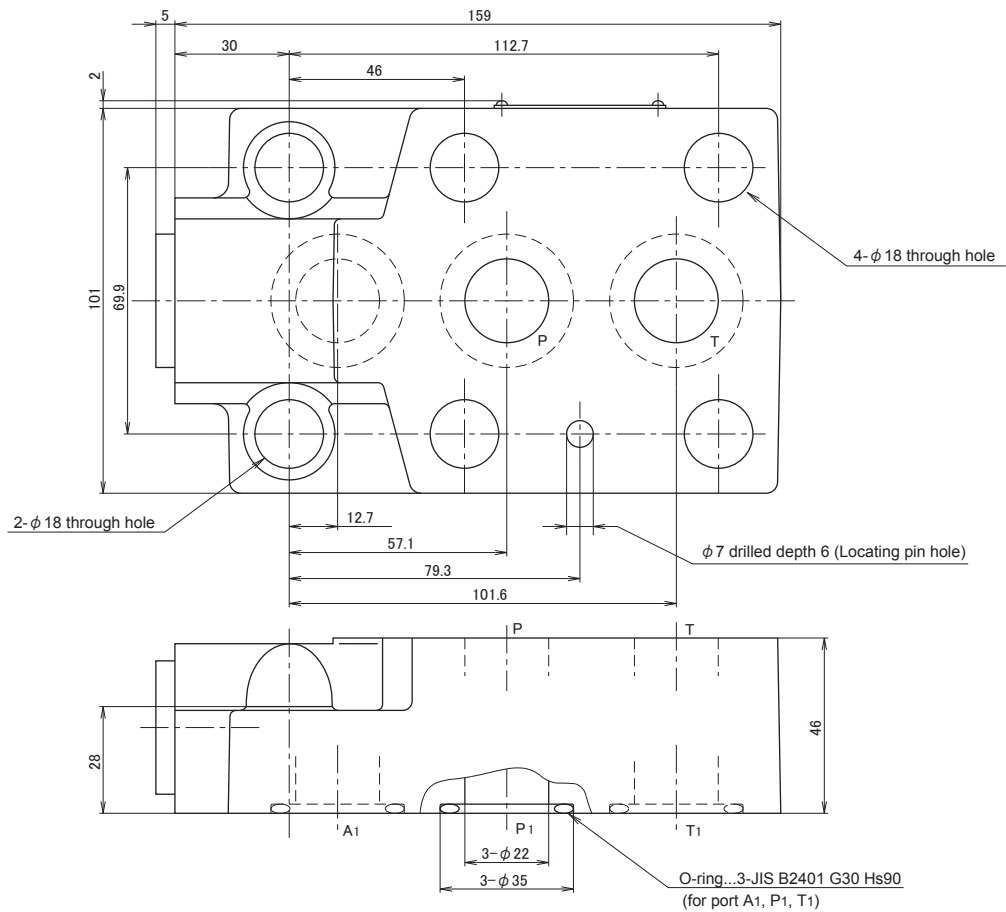

●ZA30

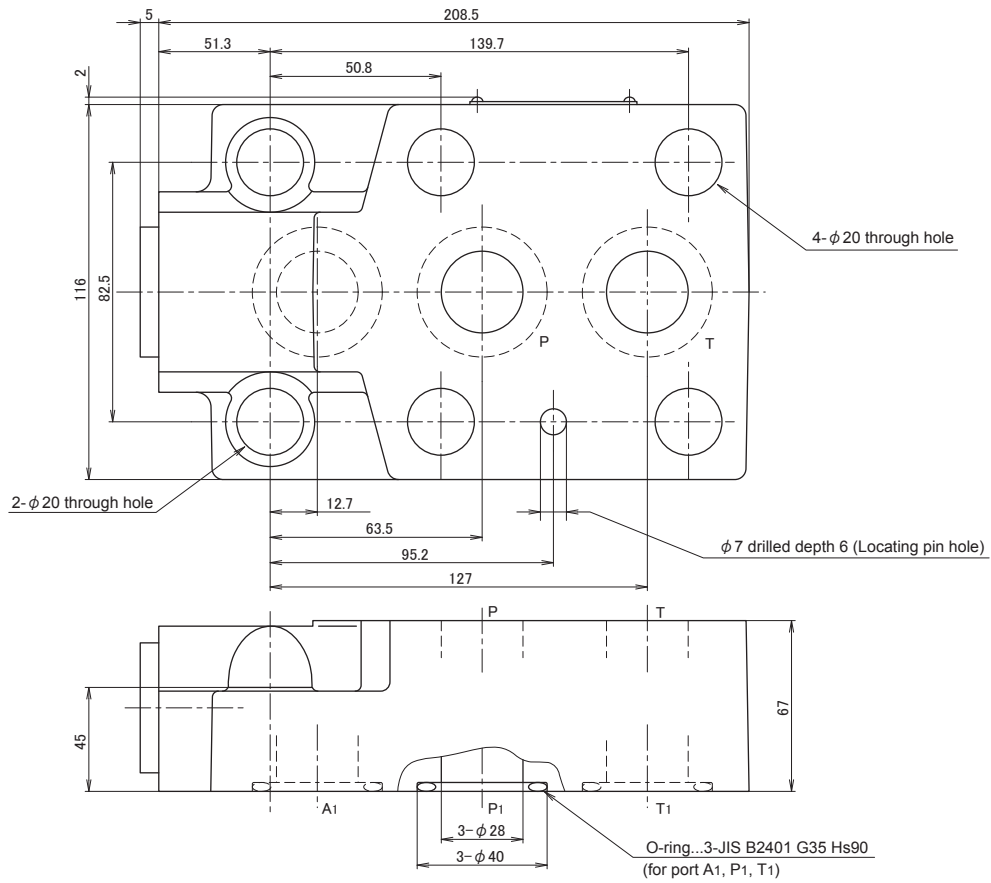

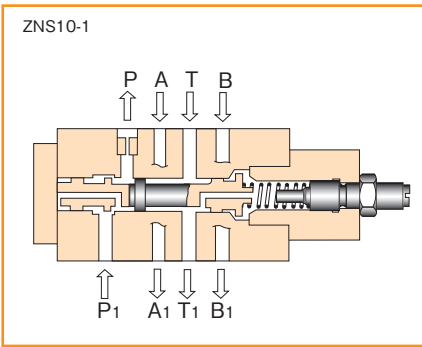

Type indication

ZNS 6 - 1 - 10 -

Sandwich type shock damping valve

Nominal dimension
5, 6, 10

Type of valve

- 1 = Shock damping valve for unloading
- 2 = Shock damping valve for 3 stage pressure

Type of hydraulic oil

- No symbol = Mineral based hydraulic oil
- V = Phosphate ester based hydraulic oil
- W = Fatty ester based hydraulic oil
- Water-glycol based hydraulic oil

Series number: 10

Hydraulic symbols

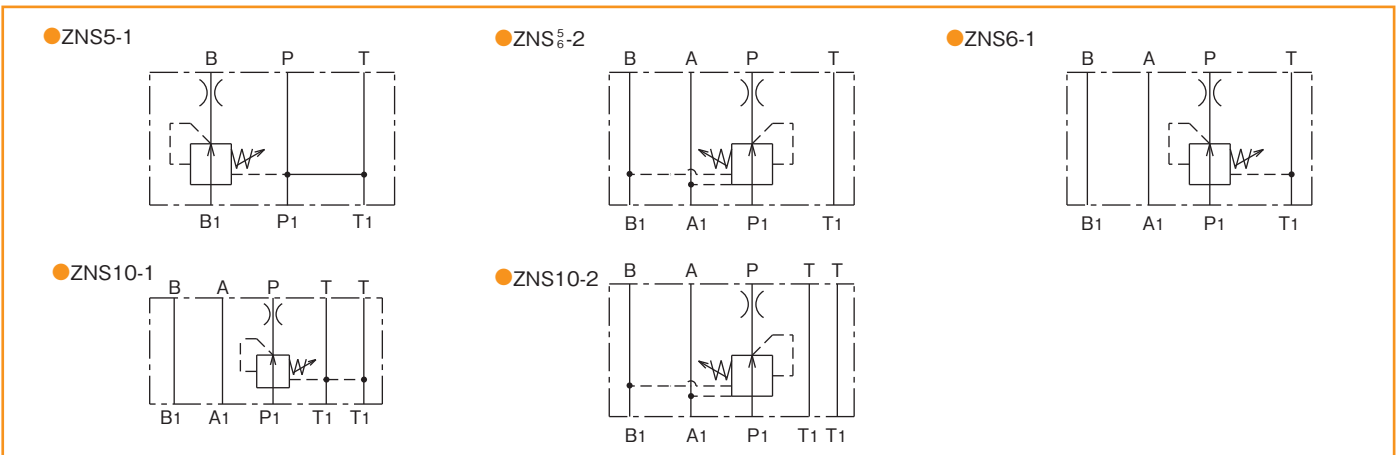

Specifications

Nominal dimension		5	6	10
Maximum working pressure MPa (kgf/cm ²)		30.9 (315)		
Maximum flow rate L/min		4	8	12
Mass kg	For unloading	1.0	1.2	1.9
	For 3 stage pressure	1.7	1.7	2.1

Mounting bolt

Type	Hexagon socket head cap thread	Quantity	Tightening torque N·m (kgf·cm ²)
ZNS 5	M5×90L	4 pcs.	6.9±1.0 (70±10)
ZNS 6	M5×85L*	4 pcs.	6.4±0.5 (65±5)
ZNS 10	M6×70L*	4 pcs.	13 ±1 (133±10)

*When the solenoid valve is 10 Series, mounting bolts are as shown in the table below.

Type	Hexagon socket head cap thread	Quantity	Tightening torque N·m (kgf·cm ²)
ZNS 6	M5×90L	4 pcs.	7.4±0.5 (75±5)
ZNS 10	M6×85L	4 pcs.	11.8±1.7 (120±18)

When using the valve

- The use of a shock damping valve can eliminate a shock that occurs when a load condition is switched to a no-load condition.

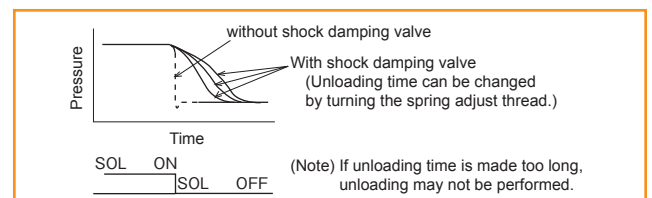

- A shock damping valve can be incorporated into the following relief valves manufactured by us for use.

For details, refer to the section of each relief valve in the type number index.

Type of shock damping valve	Type of applicable relief valve
ZNS5-1	RBE10, 20, 30, 35 PUE10, 20, 30
ZNS5-2	3RBE10, 20, 30
ZNS10-1	RBE52, 82

Dimension drawing

ZNS5-1

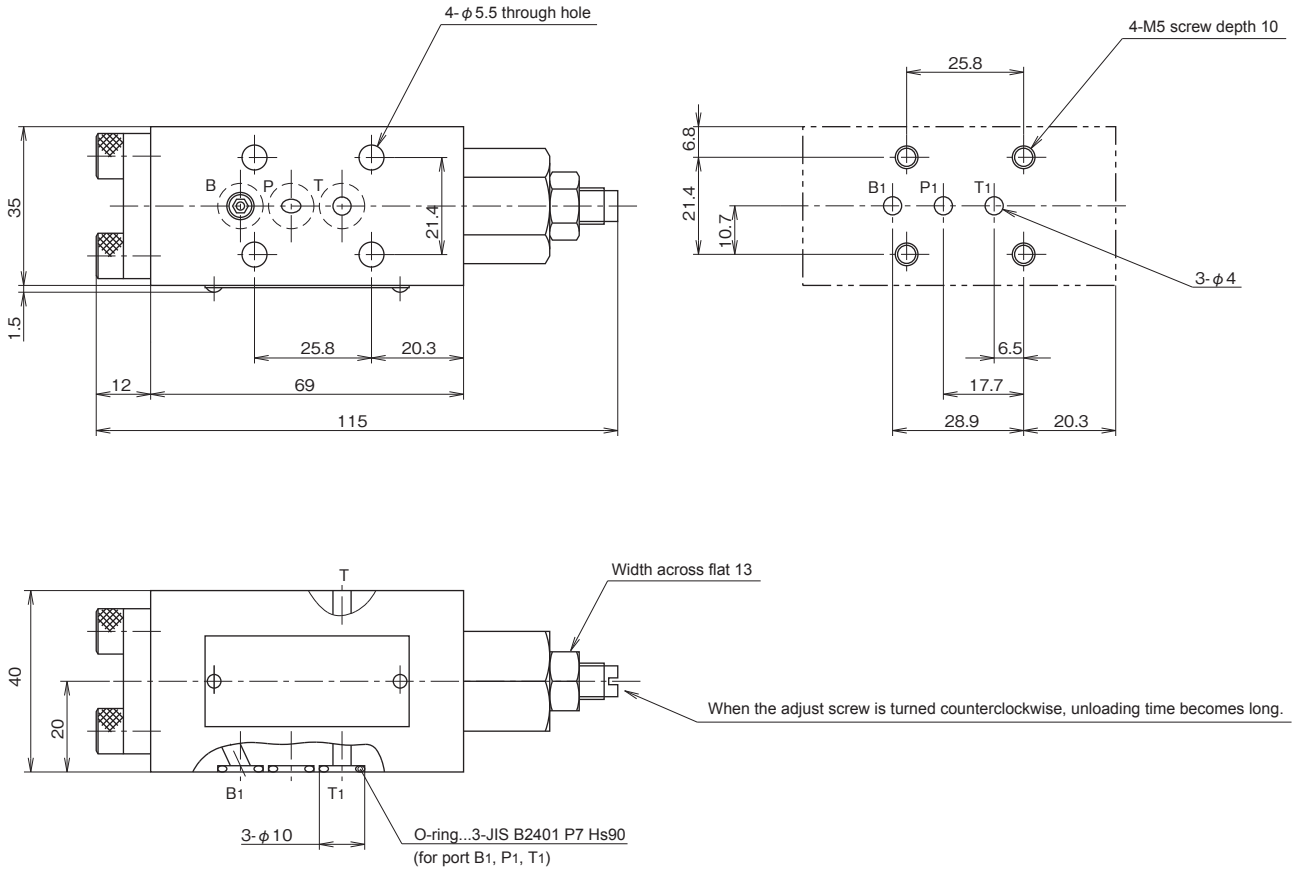

ZNS5-2

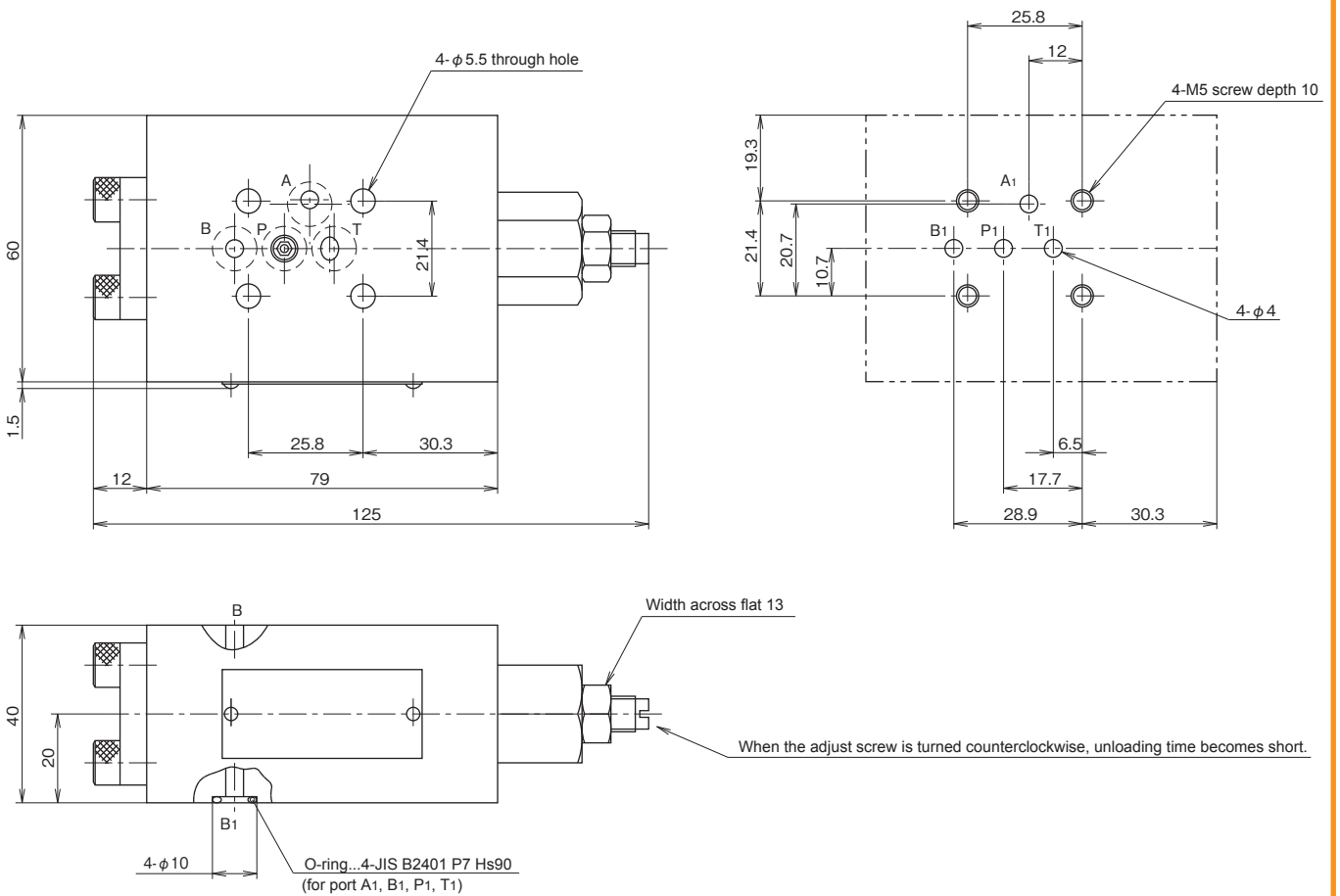

● ZNS6-1

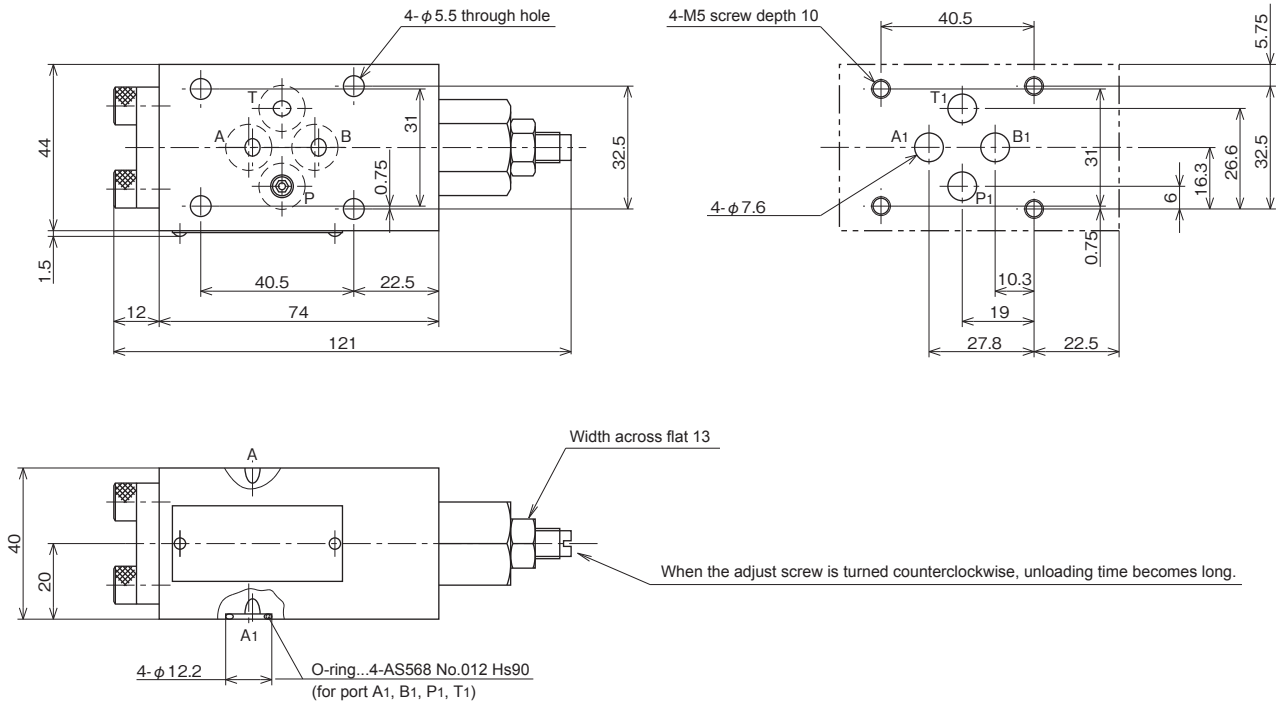

● ZNS6-2

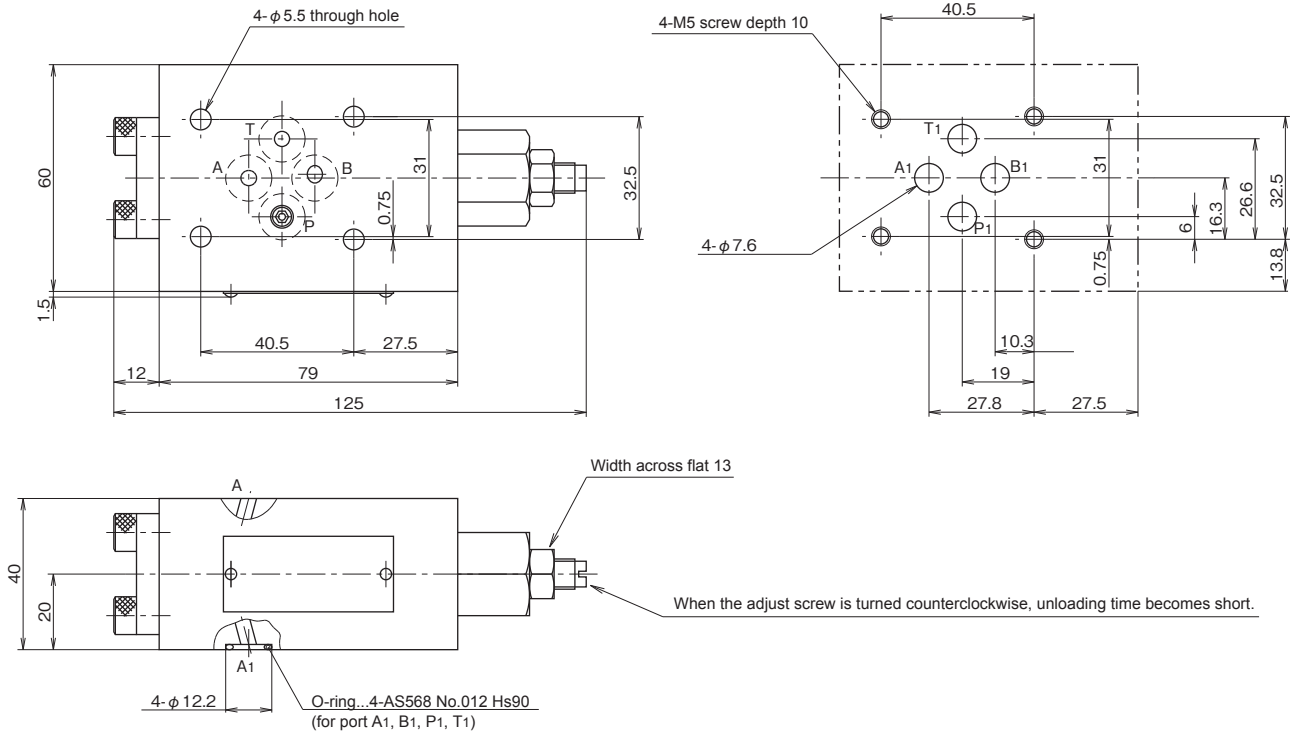

ZNS10-1

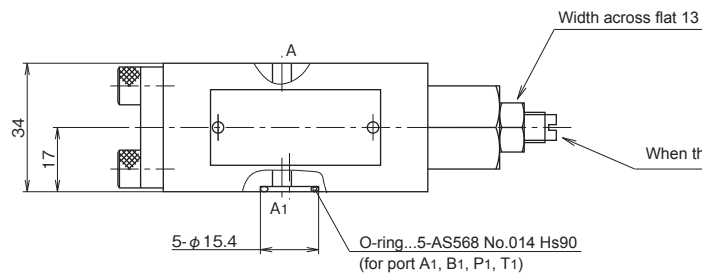
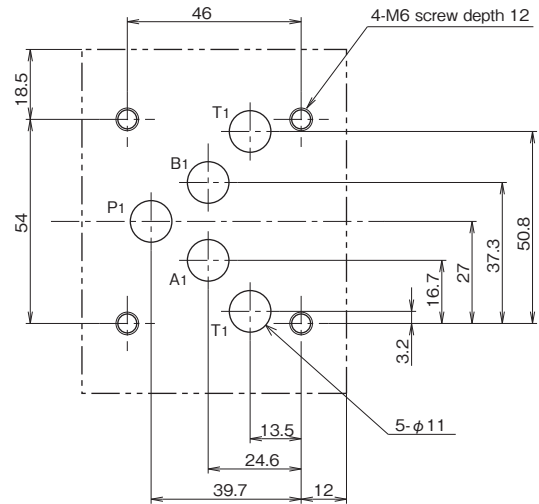
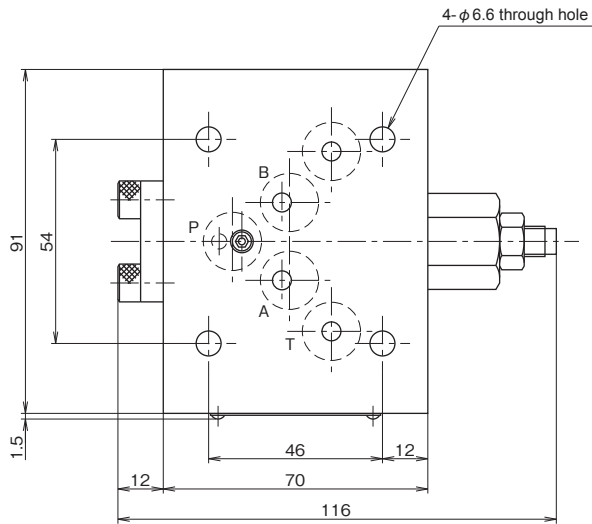

(Note) There is T port at two locations and either of the two may be used.

When the adjust screw is turned counterclockwise, unloading time becomes long.

ZNS10-2

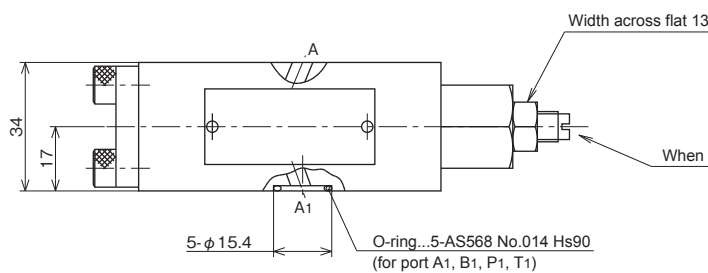
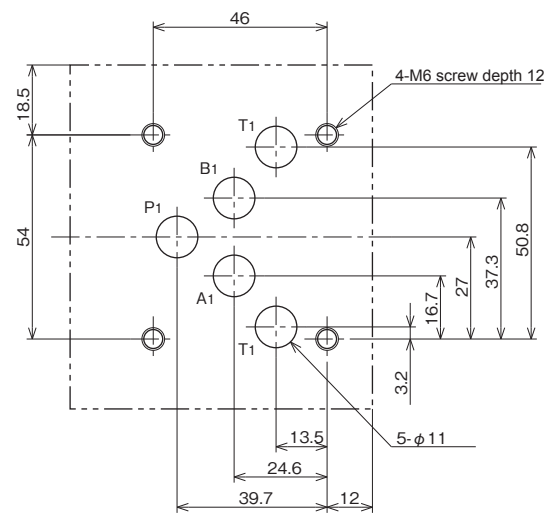
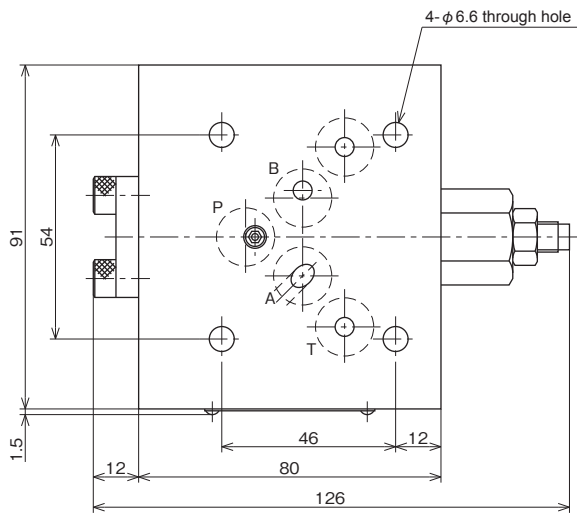

(Note) There is T port at two locations and either of the two may be used.

When the adjust screw is turned counterclockwise, unloading time becomes short.

Logic valve

	Page
Logic valve	KLD/LU 5-2
Selector valve	CS 5-25
Logic element for pressure control...	LR/LPR 5-28

In the type selection, we recommend the one indicated in color letters in the type indication explanation.

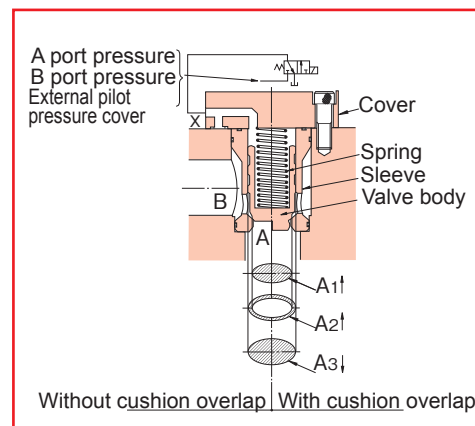

Structure and operation of logic elements

● Structure

Logic elements consists of, as shown in the figure, a sleeve with internal seat, valve body, spring that always holds the valve body, and control ports, and the cover on which various types of valves and stroke limiters are to be installed.

There are two types of valve body, with and without cushion overlap, each of which can be used for different usage. Though the valve body with the cushion overlap has higher flow resistance, it is used as a flow rate control valve in combination with a stroke limiter, or in order to tame switching shock under high pressure.

● Operation

The hydraulic oil can flow in both direction of $A \rightarrow B$ and $B \rightarrow A$, and open and close of the valve body are determined by the pressure in the pilot room. Hence, the pilot pressure is led internally or externally and controlled.

Supposing that there is no pressure applied in the pilot room, the valve opens when the hydraulic force of A or B port becomes higher than the spring force, and if pressure is applied, the valve opens when the pressure of A or B port increases by the corresponding area ratio. The three areas shown in the figure significantly affect the functions. Assuming that the area A1 is 100%, the ring shape area A2 is, depending on the type, 7% or 50%. Hence the area ratio A1:A2 is 14.3:1, or 2:1 respectively, and the area A3 which is computed by $(A1 + A2)$ becomes 107% or 150% of A1 respectively. The area A3 is determined by each nominal dimension and common to the types, while A1 varies depending on the type. Cracking pressure for spring type 40 logic element KLD ···-10-C40, if there is no pilot pressure applied, is shown in the table depending on the type.

Logic element type		KLD··· -10-C40	KLD··· -10-D40
Area ratio A1:A2		2:1	14.3:1
Cracking pressure MPa (kgf/cm ²)	A port side	0.4 (4)	0.3 (2.8)
	B port side	0.8 (8)	3.9 (40)

As shown above, selecting each cartridge assembly in combination with various cover for the usage allows a large variety of controls.

Specifications

Nominal dimension		16	25	32	40	50	63	80	100
Maximum working pressure MPa (kgf/cm ²)	Port A, B, X Z1, Z2	Solenoid operated directional valve 30.9 MPa (For 315 kgf/cm ²) with cover							
	Other covers	41.2 (420)							
Sheet area A1 cm ²	Area ratio 2:1	1.54	3.3	5.3	9.24	16.6	22.9	37.9	63.6
	Area ratio 14.3:1	2.14	4.6	7.55	12.88	22.9	32.2	52.8	89.0
Ring shape area A2 cm ²	Area ratio 2:1	0.73	1.61	2.74	4.61	8.03	11.3	18.8	31.4
	Area ratio 14.3:1	0.13	0.31	0.49	0.97	1.73	2.0	3.9	6.0
Poppet area A3 cm ²		2.27	4.91	8.04	13.85	24.63	34.2	56.7	95
Poppet stroke mm	With cushion overlap	7	10	12	16	20	24	30	38
	Without cushion overlap	7	8	9	12	16	19	24	30
Stroke volume cm ³	With cushion overlap	1.6	4.9	9.7	22.2	49.2	82	170	361
	Without cushion overlap	1.6	3.9	7.2	16.6	39.4	65	136	285
Mass kg	Cartridge assembly	0.2	0.4	1.0	1.8	3.8	7.0	13	27
	Standard cover	1.2	2.3	4.0	7.4	10.5	21	27	42

Accessories

● Mounting bolt

Size	Type	Hexagon socket head cap thread	Quantity	Tightening torque N·m (kgf·cm)
	Cover type			
LU16	All types	M 8×40L	4 pcs.	29.4± 4.4 (300±45)
LU25	All types	M12×50L	4 pcs.	98.0± 14.7 (1000±150)
LU32	All types	M16×60L	4 pcs.	235.2± 35.2 (2400±360)
LU40	S1, S2, S3	M20×80L	4 pcs.	431.2± 64.6 (4400±660)
	All types other than above	M20×70L	4 pcs.	
LU50	S2, S4	M20×100L	4 pcs.	1568.0±196.0 (16000±2000)
	All types other than above	M20×80L	4 pcs.	
LU63	S2, S4	M30×120L	4 pcs.	1568.0±196.0 (16000±2000)
	All types other than above	M30×100L	4 pcs.	
LU80	S2, S4	M24×120L	8 pcs.	784.3±118.0 (8000±1200)
	All types other than above	M30×100L	8 pcs.	
LU100	S2, S4	M30×120L	8 pcs.	1568.0±196.0 (16000±2000)
	All types other than above	M30×100L	8 pcs.	

Type indication

● Logic element

KLD 16 C - 10 - C 00 -

Logic element

Nominal dimension

16, 25, 32, 40, 50
63, 80, 100

Connection method

C = Cartridge type

Series number: 10

Poppet pressurized area ratio and poppet type

Symbol	Area ratio (A1:A2)	Poppet type
A	2:1	Without cushion overlap
B	14.3:1	Without cushion overlap
C	2:1	With cushion overlap
D	14.3:1	With cushion overlap

Type of hydraulic oil

No symbol = Mineral based hydraulic oil

Fatty ester based hydraulic oil

Water-glycol based hydraulic oil

V = Phosphate ester based hydraulic oil

Cracking pressure

Symbol	Area ratio 2:1	Area ratio 14.3:1
00	No spring	No spring
05	0.05MPa(0.5kgf/cm ²)	0.03MPa(0.35kgf/cm ²)
10	0.1MPa(1.0kgf/cm ²)	0.07MPa(0.7 kgf/cm ²)
20	0.2MPa(2.0kgf/cm ²)	0.14MPa(1.4 kgf/cm ²)
30	0.29MPa(3.0kgf/cm ²)	0.21MPa(2.1 kgf/cm ²)
40	0.39MPa(4.0kgf/cm ²)	0.28MPa(2.8 kgf/cm ²)

(When pressure is applied to the port A)

● Logic valve cover

LU 16 S1 - 10 / FX 08 -

Logic valve cover

Nominal dimension

16, 25, 32, 40, 50
63, 80, 100

Cover type

*Refer to "Cover type symbols".

Series number: 10

Types with/without eternal pilot ports

(Only applicable for cover type A and S)

No symbol = not provided

F = provided

Type of hydraulic oil

No symbol = Mineral based hydraulic oil

V = Phosphate ester based hydraulic oil

W = Fatty ester based hydraulic oil

Water-glycol based hydraulic oil

Restriction contraction diameter

*Refer to "Restriction contraction diameter symbols".

Symbol of passage to which restriction contractor is mounted
(Please see the hydraulic symbol paragraph.)

Cover type	Symbol of passage to which restriction contractor is mounted
A	X = The restriction contractor is mounted on the X-passage
S	
C	F = The restriction contractor is mounted on the F-passage
D	P = The restriction contractor is mounted on the P-passage
E	A = The restriction contractor is mounted on the A-passage
F	B = The restriction contractor is mounted on the B-passage T = The restriction contractor is mounted on the T-passage

● Selection of a pilot valve

The pilot valves shown on the table below can be used for logic valve cover.

If you need the pilot valve, designate the pilot valve type separately.

We will deliver the logic valve cover and the pilot valve separately.

Cover type	Nominal dimension						
	25	32	40	50	63	80	100
D							
E	DE6P-20-204...			DE10P-20-204...			
F							

(Note) For the detail of the pilot valve, see the paragraph "DE**", solenoid operated directional valve.

Cover type symbols

Symbol	Type	Nominal dimension	16	25	32	40	50	63	80	100
A	Standard	Types with external pilot valve	○	○	○	○	○	○	○	○
		Types without external pilot valve	○	○	○	—	—	—	—	—
S1	With a handle type stroke limiter	Types with external pilot valve	○	○	○	○	—	—	—	—
		Types without external pilot valve	○	○	○	—	—	—	—	—
S2	With a thread type stroke limiter	Types with external pilot valve	○	○	○	○	○	○	○	○
		Types without external pilot valve	○	○	○	—	—	—	—	—
S3	With a scale type stroke limiter with a key	Types with external pilot valve	○	○	○	○	—	—	—	—
		Types without external pilot valve	○	○	○	—	—	—	—	—
S4	With a scale type stroke limiter	Types with external pilot valve	○	○	○	○	○	○	○	○
		Types without external pilot valve	○	○	○	—	—	—	—	—
B	With a shuttle valve (Selector valve)		○	○	○	○	○	○	○	○
C	With a pilot operation sheet valve									
D	A	For mounting a solenoid operated directional valve	Normal close							
			Normal open							
E	B	With a shuttle valve + for mounting a solenoid operated directional valve (Selector valve)	Normal close	—	○	○	○	○	○	○
			Normal open							
F	A	With a shuttle valve + for mounting a solenoid operated directional valve (Selector valve)	Normal close							
			Normal open							

Restriction contraction diameter symbols

● Applicable for cover type A and S

Symbol	Restriction contraction diameter (mm)	Nominal dimension	16	25	32	40	50	63	80	100
06	0.6						—	—	—	—
08	0.8									
10	1.0									
12	1.2	○								
15	1.5		○	○	○					
18	1.8					○				
20	2.0						○			
25	2.5							○		○
30	3.0									
35	3.5									
40	4.0	—	—	—	—					
50	5.0					—				
60	6.0									
80	8.0							—	—	

● Applicable for cover types C, D, E, F

Symbol	Restriction contraction diameter (mm)	Nominal dimension	25	32	40	50	63	80	100
06	0.6						—	—	—
08	0.8								
10	1.0								
12	1.2	○							
15	1.5		○	○	○				
18	1.8					○	○		
20	2.0							○	○
25	2.5								
30	3.0		—	—	—				
35	3.5								

Hydraulic symbols

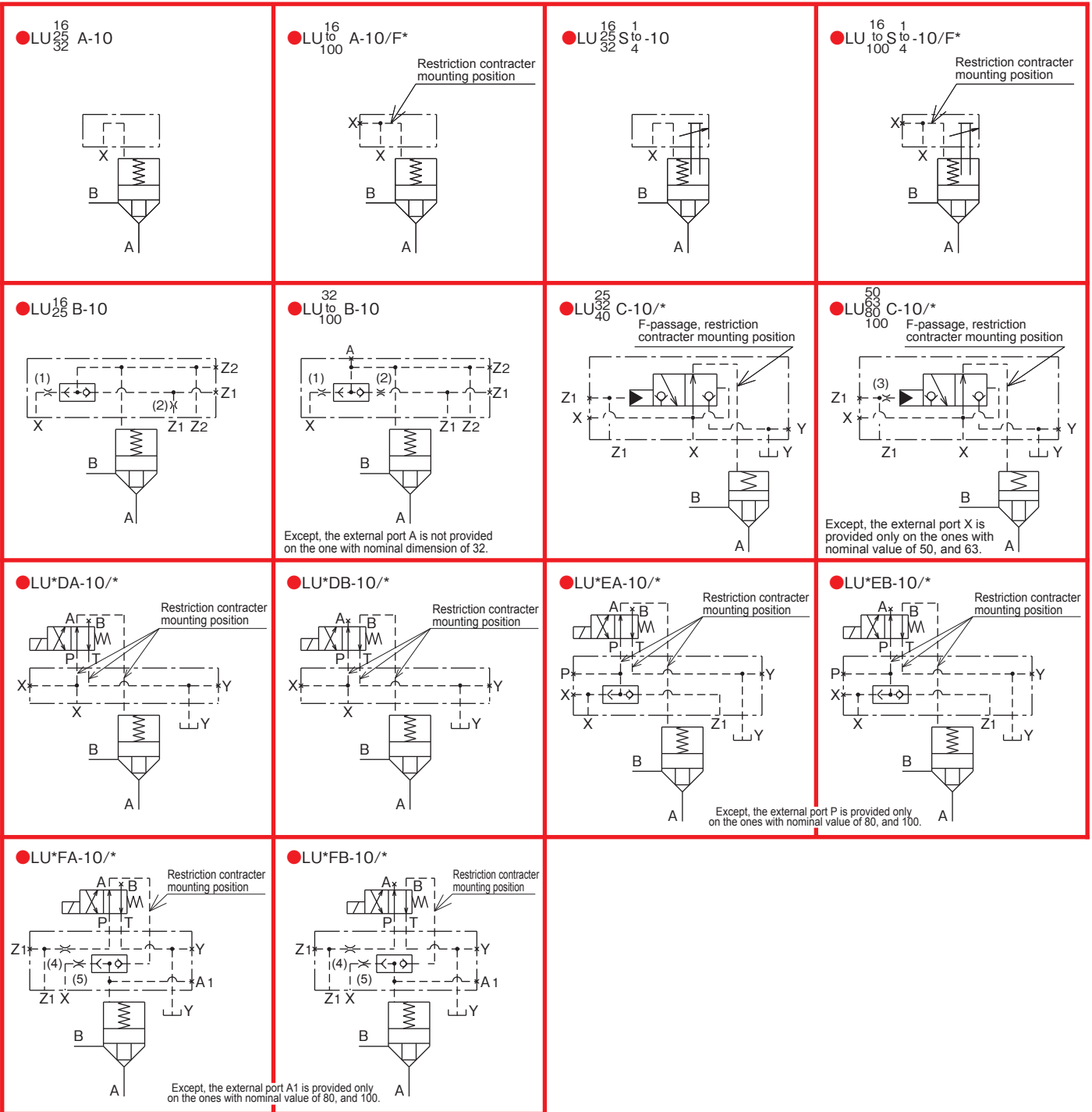

• As for the diameter of restriction contraction (1) to (5) among the above hydraulic symbols
The following restriction contractors are mounted on the cover types shown on the table below.

Cover type	Restriction contraction diameter	Nominal dimension							
		16	25	32	40	50	63	80	100
B	Restriction contraction diameter (1)	M4-φ1	φ1.5*	M6-φ1	M6-φ1.2	M8-φ1.5	M8-φ1.8	M8-φ2	M8-φ2
	Restriction contraction diameter (2)	M4-φ1	M4-φ1	M6-φ1	M6-φ1.2	M8-φ1.5	M8-φ1.8	M8-φ2	M8-φ2
C	Restriction contraction diameter (3)					M8-φ1.2	M8-φ1.2	M8-φ1.2	M8-φ1.2
F	Restriction contraction diameter (4)		M6-φ1	M6-φ1	M6-φ1.2	M8-φ1.5	M8-φ1.8	M8-φ2	M8-φ2
	Restriction contraction diameter (5)		φ1.5*	M6-φ1	M6-φ1.2	M8-φ1.5	M8-φ1.8	M8-φ2	M8-φ2

(Note) The ones with * mark have restriction contraction directly processed on the cover.

Pressure decreasing characteristics (Viscosity 36 mm²/s (cSt)) In case of no spring

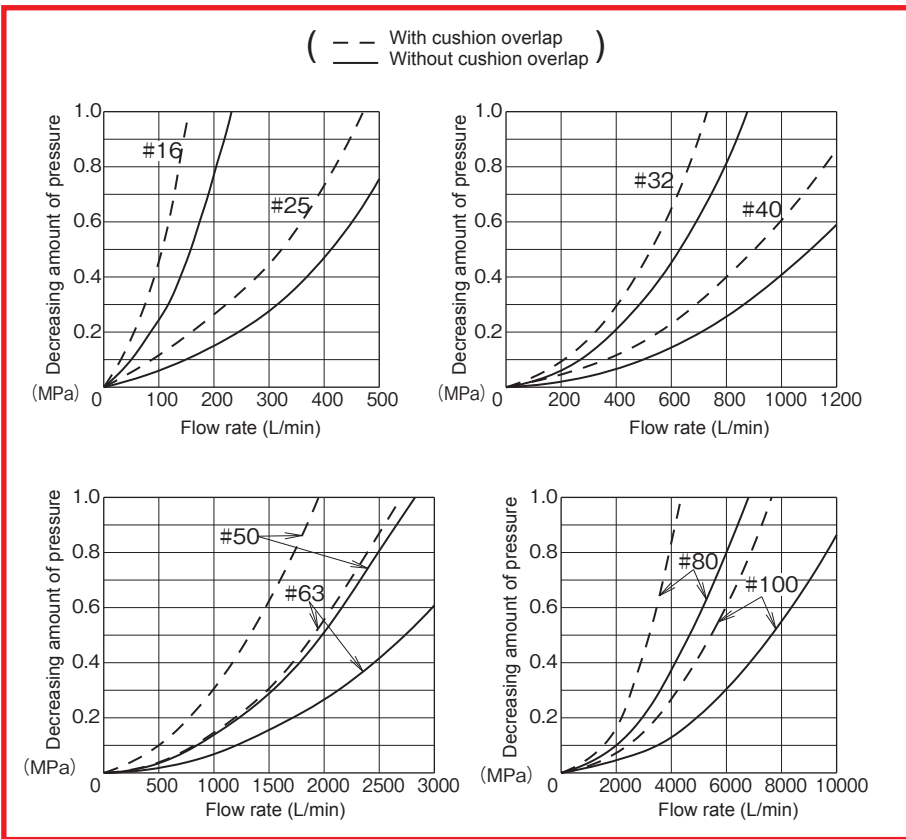

Pressure – Flow rate characteristics (Viscosity 36 mm²/s (cSt))

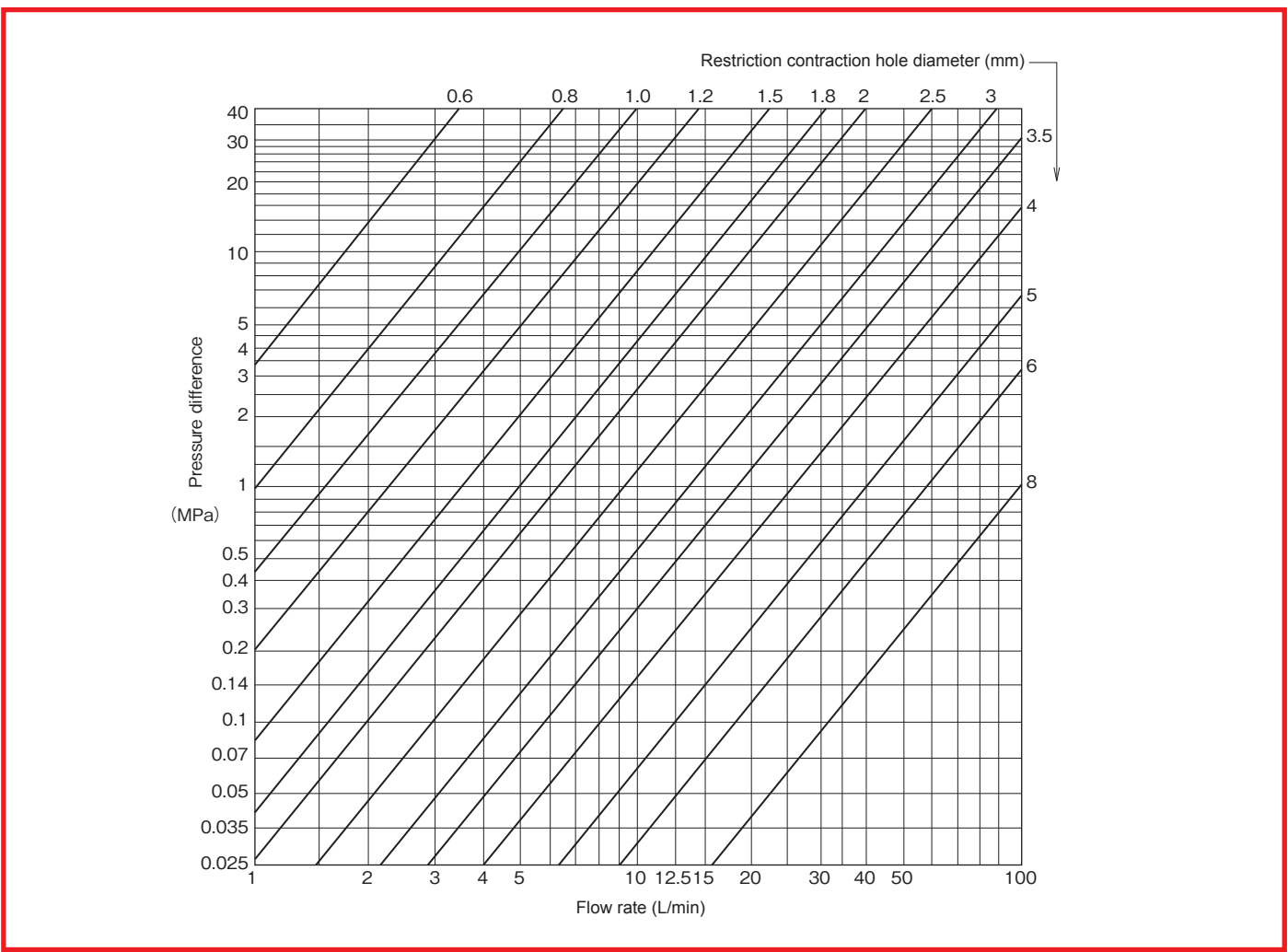

Dimension drawing

KLD

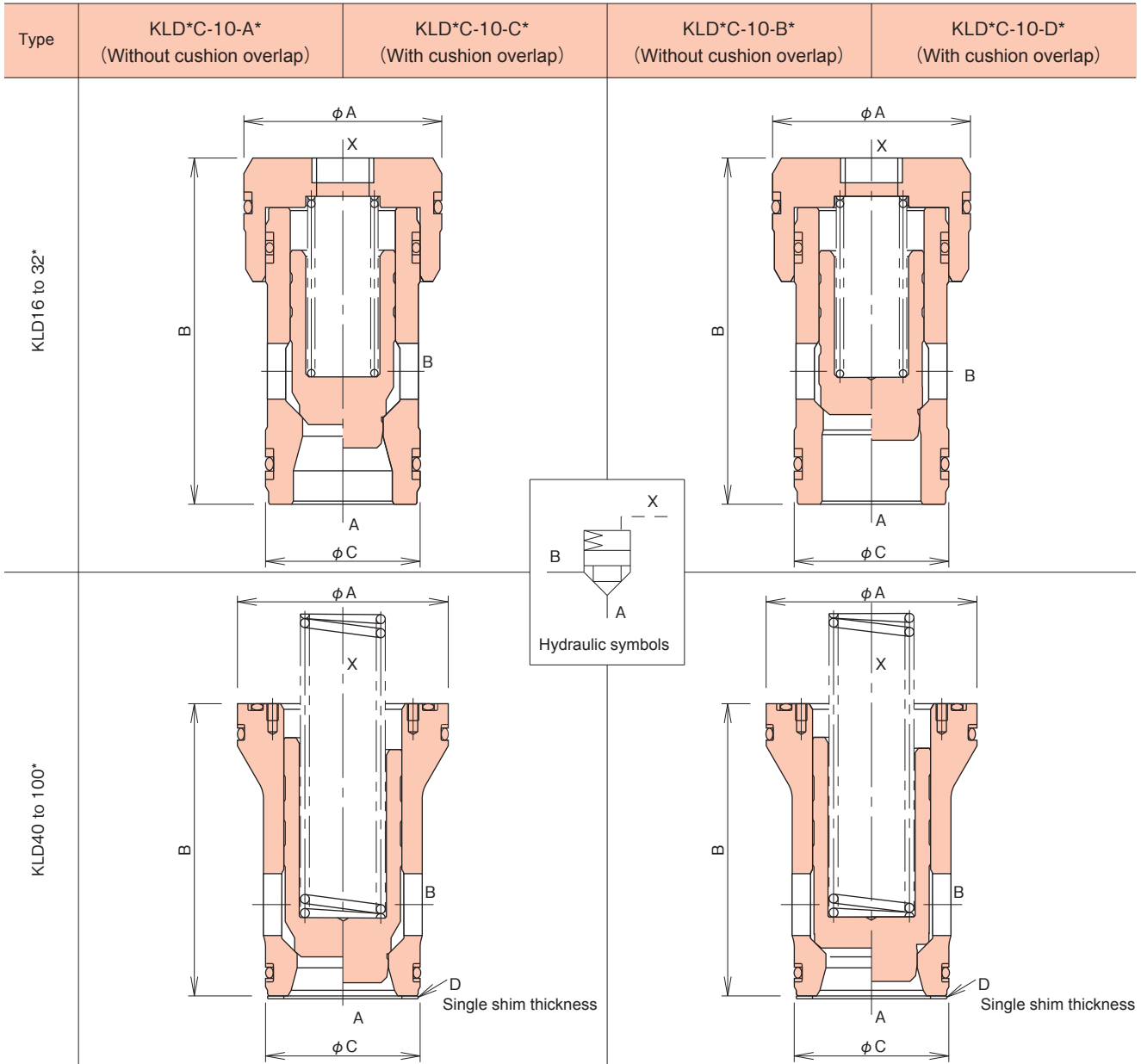

Nominal dimension	16	25	32	40	50	63	80	100
ϕA	32	45	60	75	90	120	145	180
B	56	72	85	104	121	153	203	243
ϕC	25	34	45	55	68	90	110	135
D	—	—	—	1	1	2	2	2

● Selecting procedure of a shim

1. Three types of shims with different thickness are attached.
2. Select one shim out of the three and assemble it to the manifold or block.
Assemble them so as the gap between the bushing and manifold to be 0 to 50 μ .

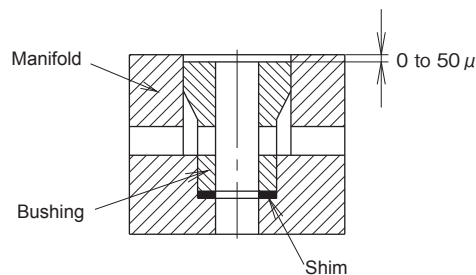

●KLD - manifold Machining Drawings [Conforming to the dimension in DIN24342, ISO(Under deliberation)]

●KLD16, 25, 32, 40, 50, 63

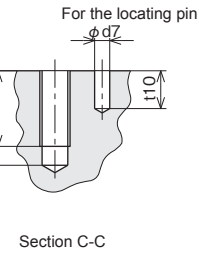
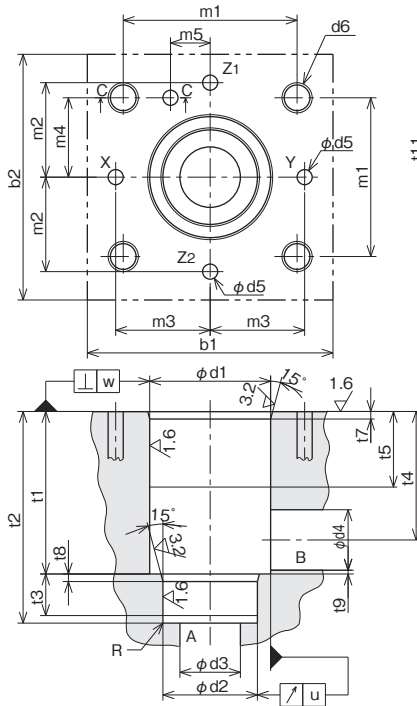

- A : Service port
- B : Service port
- X : Pilot port
- Y : Drain port
- Z1: } Supplemental pilot port
- Z2: }

Note)
 *1. B port can be machined arbitrarily in the depth range between (t1-t9) to t5. Also, it can be machined every 90 degrees to the A port shaft.

*2. Finishing range

●KLD80, 100

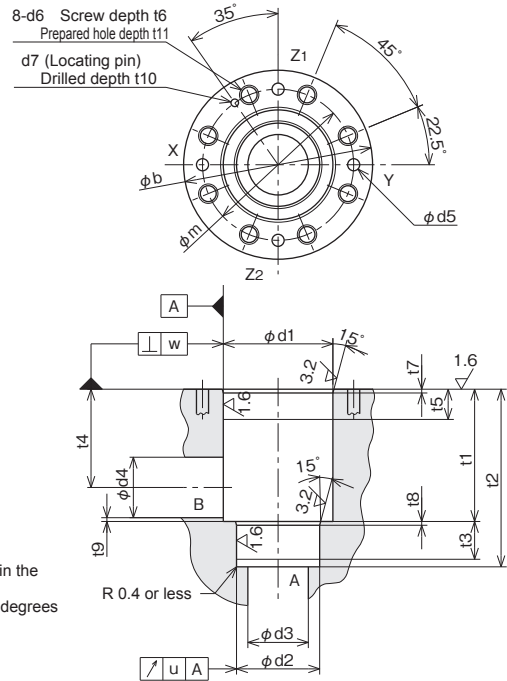

Symbol	Size	16	25	32	40	50	63
b1		65	85	102	125	140	180
b2		65	85	102	125	140	180
d1H7		32	45	60	75	90	120
d2H7		25	34	45	55	68	90
d3		16	25	32	40	50	63
d4	*1	16	25	32	40	50	63
d4max	*1	25	32	40	50	63	80
d5max		4	6	8	10	10	12
d6		M8	M12	M16	M20	M20	M30
d7 +0.1/0		4	6	6	6	8	8
m1 ±0.2		46	58	70	85	100	125
m2 ±0.2		25	33	41	50	58	75
m3 ±0.2		25	33	41	50	58	75
m4 ±0.2		23	29	35	42.5	50	62.5
m5 ±0.2		10.5	16	17	23	30	38
t1 ±0.1		43	58	70	87	100	130
t2 +0.1/0		56	72	85	105	122	155
t3 *2		11	12	13	15	17	20
t4 *1		34	44	52	64	72	95
t4 (When d4max)*1		29.5	40.5	48	59	65.5	86.5
t5 *2		20	30	30	30	35	40
t6		20	25	35	45	45	65
t7		2	2.5	2.5	3	4	4
t8		2	2.5	2.5	3	4	4
t9min		0.5	1.0	1.5	2.5	2.5	3
t10		10	10	10	10	10	10
t11max		25	31	42	53	53	75
u		0.03	0.03	0.03	0.05	0.05	0.05
w		0.05	0.05	0.1	0.1	0.1	0.2
Rmax		0.2	0.2	0.2	0.4	0.4	0.4
d2 Prepared hole dimension min.		24.5	33.5	44.5	54.4	67.4	89.4

Symbol	Size	80	100
bmax		250	300
d1H7		145	180
d2H7		110	135
d3		80	100
d4	*1	80	100
d4max	*1	100	125
d5max		16	20
d6		M24	M30
d7 +0.1/0		10	10
m ±0.3		200	245
t1 ±0.2		175	210
t2 +0.1/0		205	245
t3 *2		25	29
t4 *1		130	155
t4 (When d4max)*1		120	142
t5 *2		40	50
t6		50	63
t7		5	5
t8		5	5
t9min		4.5	4.5
t10min		10	10
t11max		57	73
u		0.05	0.05
w		0.2	0.2
Rmax		0.4	0.4
d2 Prepared hole dimension min.		109	134

● LU¹⁶₂₅³² A

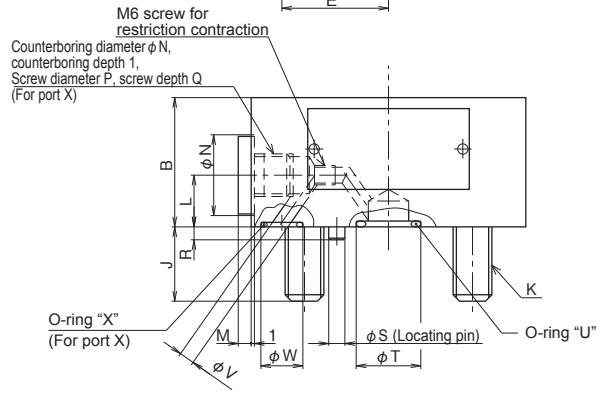
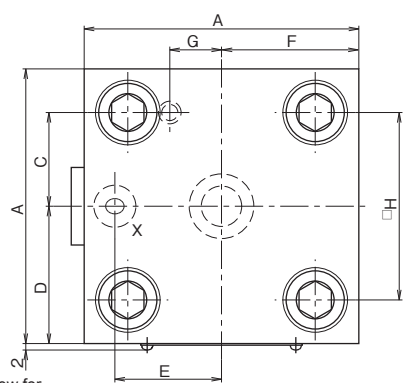

● Hydraulic symbols

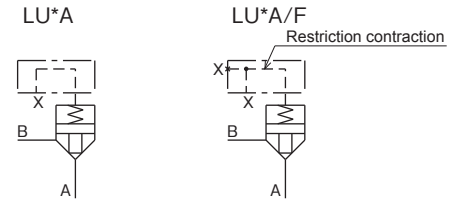

(Note) This drawing show the types with external pilot ports.
For types without external pilot port, G-plug and M6 screw for restriction contraction are not provided.

Nominal dimension	A	B	C	D	E	F	G	H	J	K	L	M	N	P	Q	R	S	T	O-ring dimension "U"	V	W	O-ring dimension "X"
16	65	35	23	32.5	25	32.5	10.5	46	14	4-M8	12	2	16	G ¹ / ₈	9	3	3	16	JIS B2401 P12 Hs90	3.2	11	JIS B2401 P8 Hs90
25	85	40	29	42.5	33	42.5	16	58	23	4-M12	16	4	25	G ¹ / ₄	12	4	5	20	JIS B2401 P16 Hs90	4.7	13	JIS B2401 P10 Hs90
32	100	50	35	50	41	50	17	70	27.5	4-M16	16	4	25	G ¹ / ₄	12	4	5	26	JIS B2401 P22 Hs90	4.7	14	JIS B2401 P10A Hs90

● LU¹⁶₂₅³² S

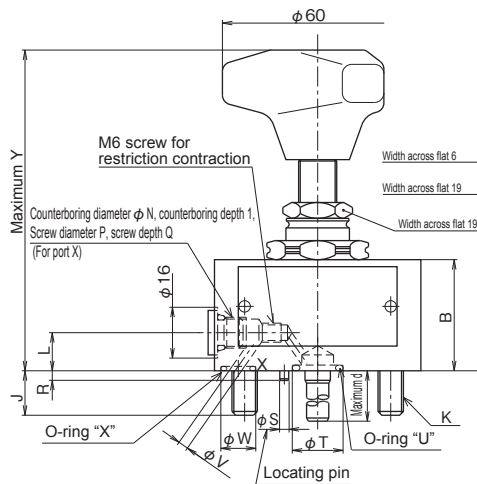
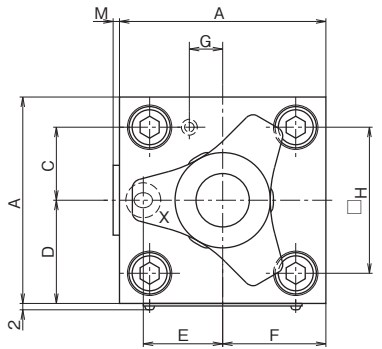

● Hydraulic symbols

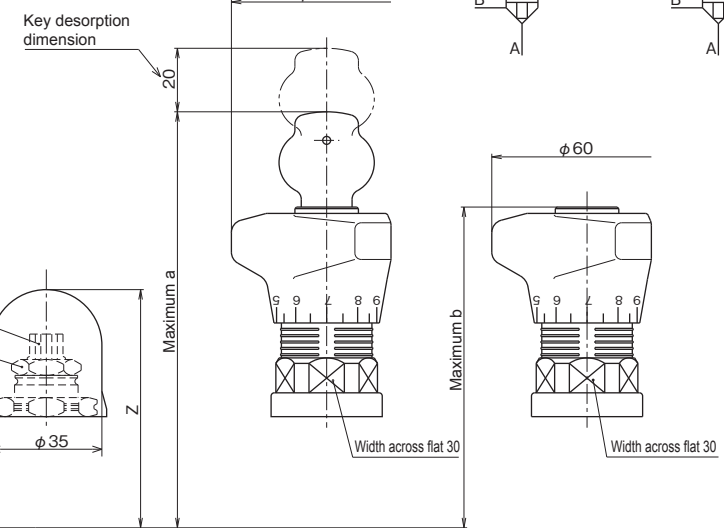
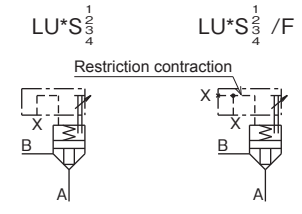

● With a handle type stroke limiter

- Screw type
- Scale type with key
- Scale type

(Note) This drawing show the types with external pilot ports.
For types without external pilot port, G-plug and M6 screw for restriction contraction are not provided.

Nominal dimension	A	B	C	D	E	F	G	H	J	K	L	M	N	P	Q	R	S	T	O-ring dimension "U"	V	W	O-ring dimension "X"	Y	Z	a	b	d
16	65	35	23	32.5	25	32.5	10.5	46	14	4-M8	12	2	16	G ¹ / ₈	9	3	3	16	JIS B2401 P12 Hs90	3.2	11	JIS B2401 P8 Hs90	101	75	131	101	36
25	85	40	29	42.5	33	42.5	16	58	23	4-M12	16	4	25	G ¹ / ₄	12	4	5	20	JIS B2401 P16 Hs90	4.7	13	JIS B2401 P10 Hs90	106	80	136	106	53
32	100	50	35	50	41	50	17	70	27.5	4-M16	16	4	25	G ¹ / ₄	12	4	5	26	JIS B2401 P22 Hs90	4.7	14	JIS B2401 P10A Hs90	116	90	146	116	65

● LU¹⁶₂₅B

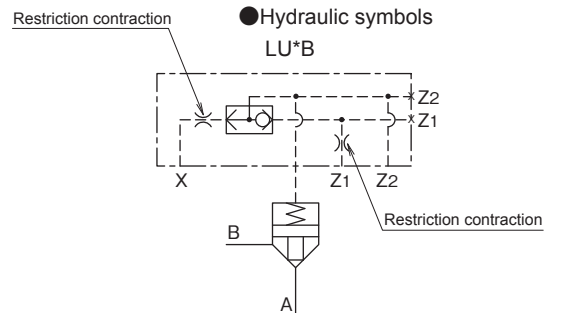
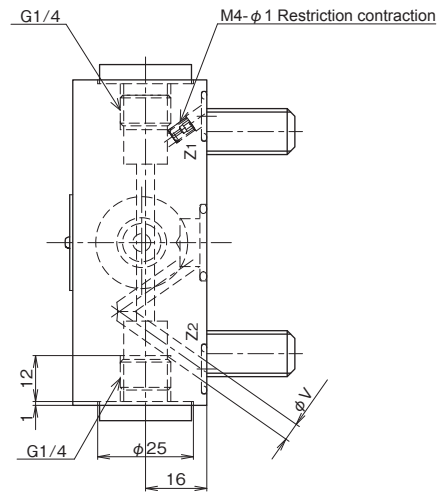
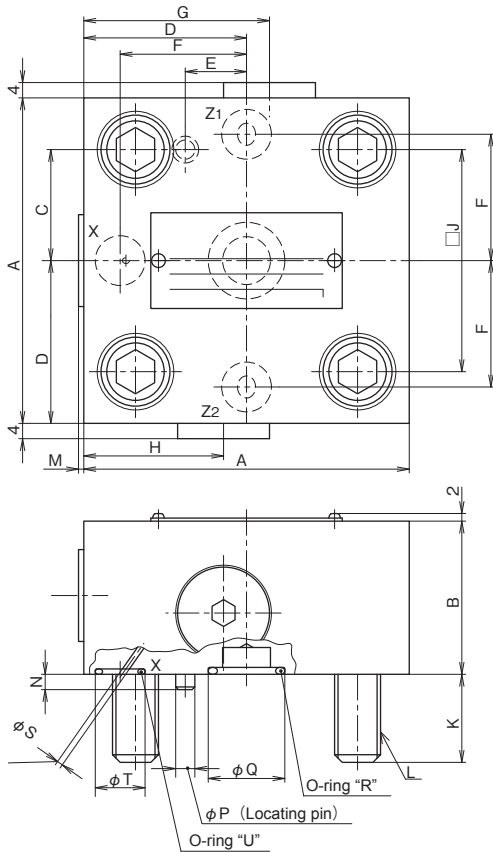

Nominal dimension	A	B	C	D	E	F	G	H	J	K	L	M	N	P	Q	O-ring dimension "R"	S	T	O-ring dimension "U"	V
16	65	35	23	32.5	10.5	25	38	31	46	14	4-M8	2	3	3	16	JIS B2401 P12 Hs90	Restriction contraction M4- ϕ 1	11	3-JISB2401 P8 Hs90	3.2
25	85	40	29	42.5	16	33	48.5	36.5	58	23	4-M12	0	4	5	20	JIS B2401 P16 Hs90	Fixed restriction contraction ϕ 1.5	13	3-JISB2401 P10 Hs90	4.7

● LU32B

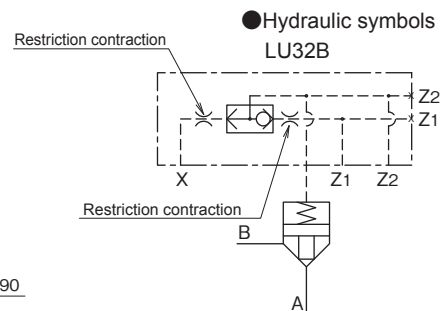
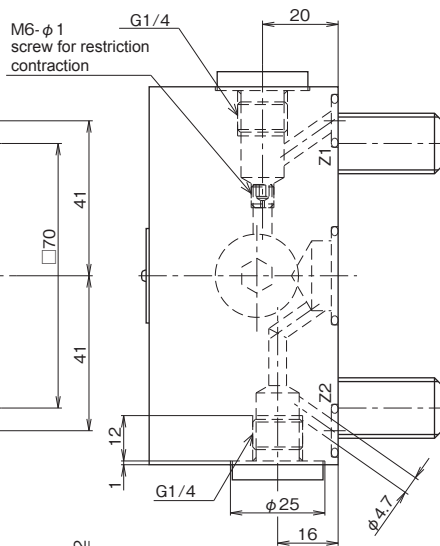
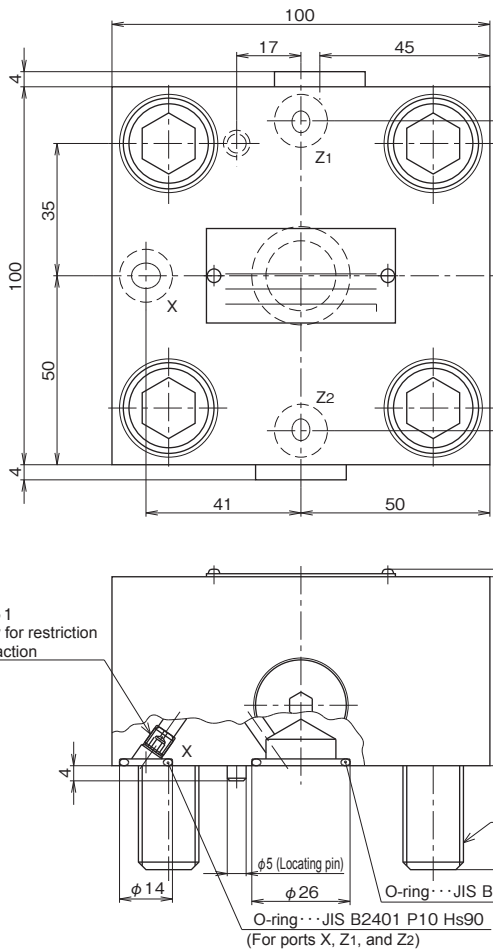

● LU25C

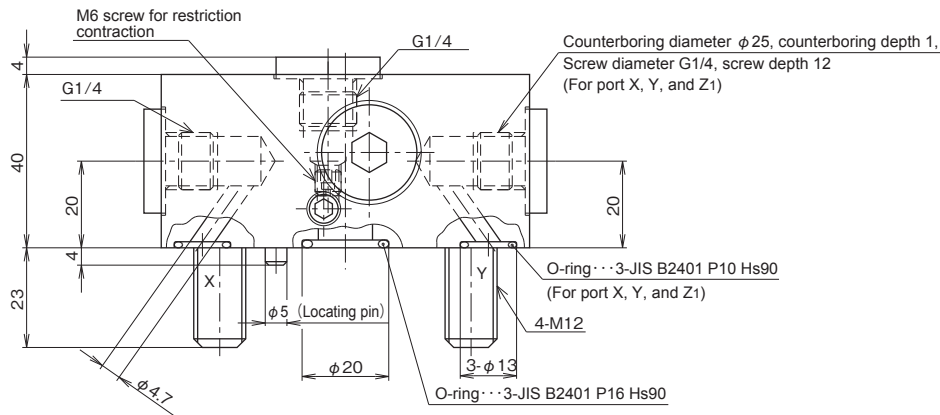
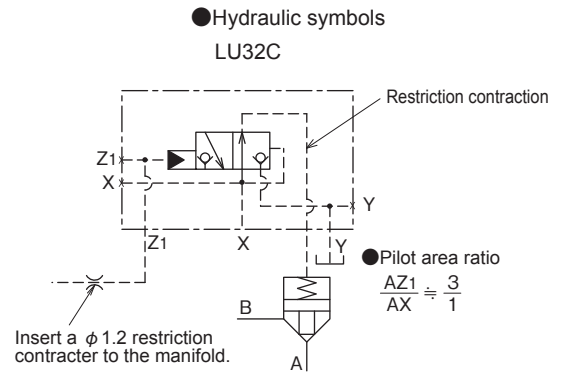
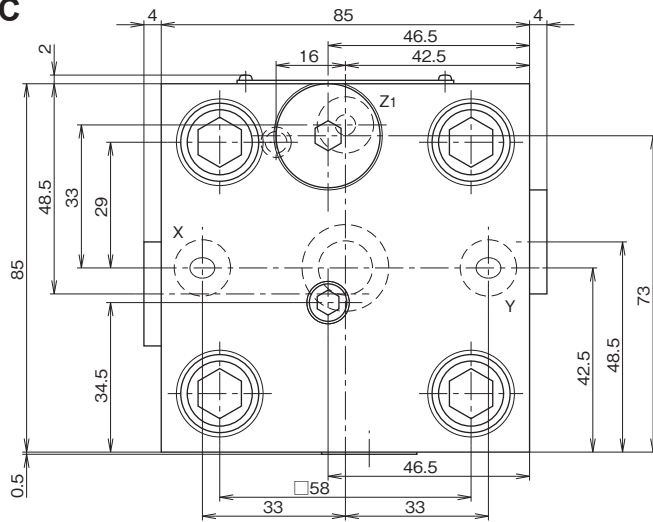

● LU32C

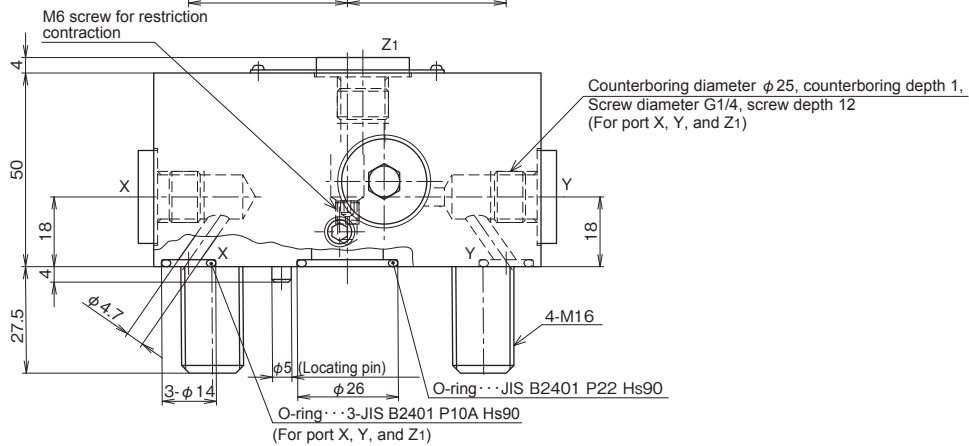
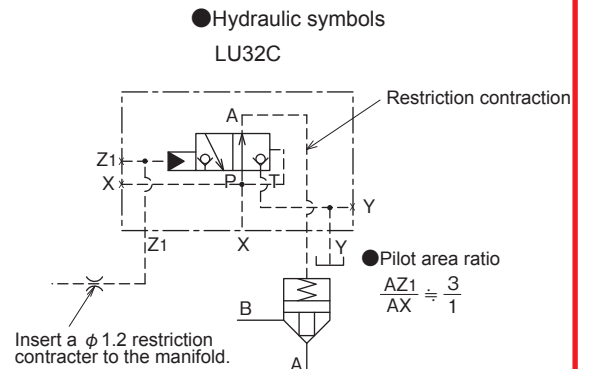
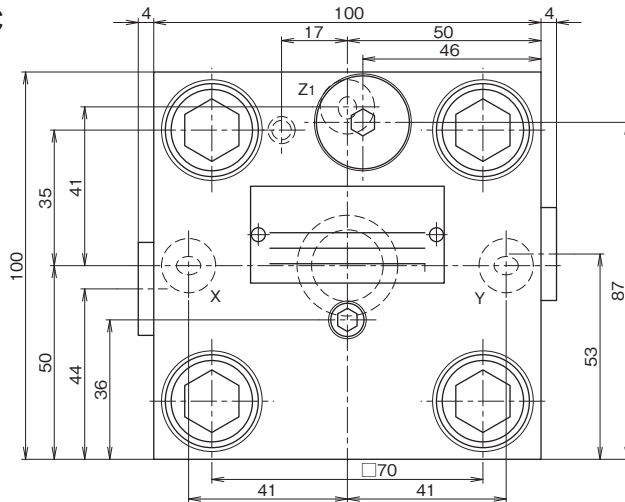

LU₂₅³²DA_B

● Hydraulic symbols

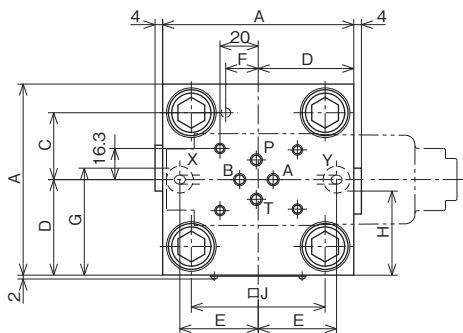

Note 1, 2
M6 plug and a screw for restriction contraction

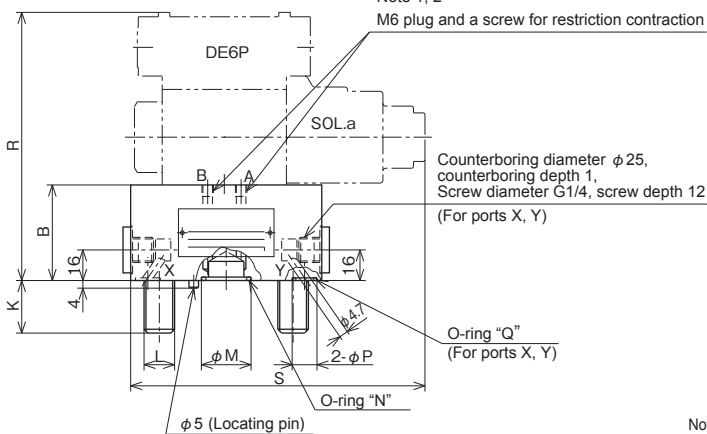

LU*DA-10/*

LU*DB-10/*

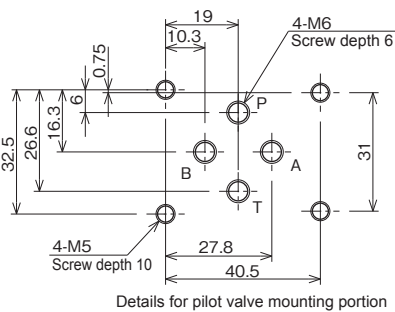
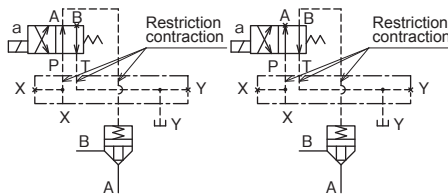

Note1. For type LU₂₅³² DA-10/*, a hexagon socket head cap set screw (M6) is provided to B port.

Note2. For type LU₂₅³² DB-10/*, a hexagon socket head cap set screw (M6) is provided to A port.

Nominal dimension	A	B	C	D	E	F	G	H	J	K	L	M	O-ring dimension "N"	P	O-ring dimension "Q"	R	S
25	85	40	29	42.5	33	16	48.5	36.5	58	23	4-M12	20	JIS B2401 P16 Hs90	13	2-JIS B2401 P10 Hs90	130	147
32	100	50	35	50	41	17	56	44	70	27.5	4-M16	26	JIS B2401 P22 Hs90	14	2-JIS B2401 P10A Hs90	140	155

LU₂₅³²EA_B

● Hydraulic symbols

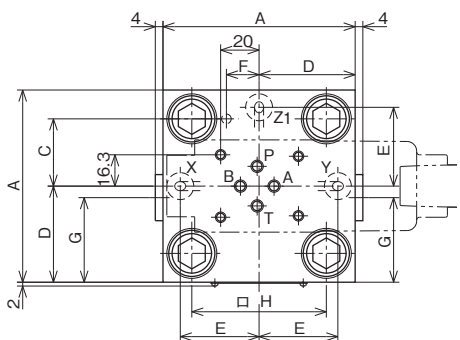

Note 1, 2
M6 plug and a screw for restriction contraction

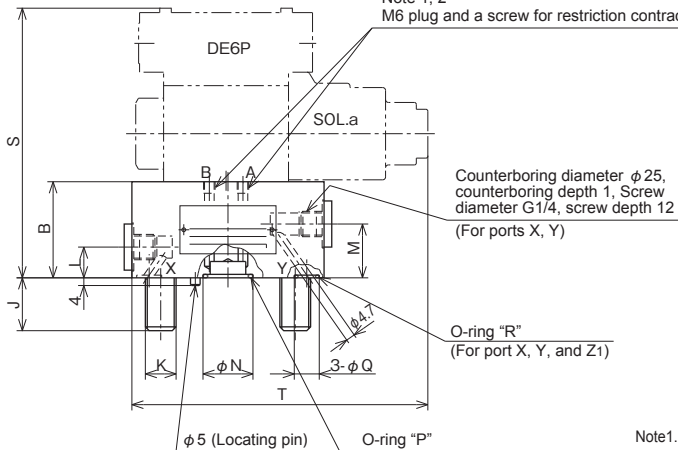

LU*EA-10/*

LU*EB-10/*

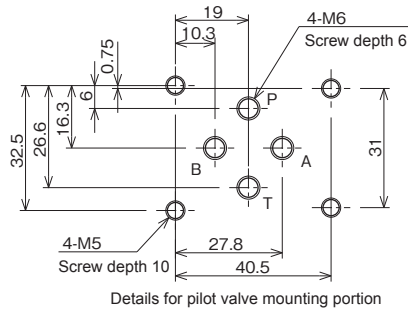
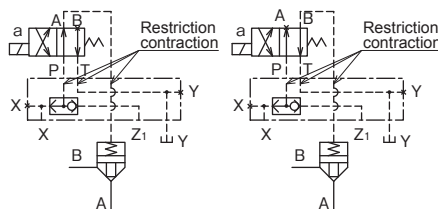

Note1. For type LU₂₅³² EA-10/*, a hexagon socket head cap set screw (M6) is provided to B port.

Note2. For type LU₂₅³² EB-10/*, a hexagon socket head cap set screw (M6) is provided to A port.

Nominal dimension	A	B	C	D	E	F	G	H	J	K	L	M	N	O-ring dimension "P"	Q	O-ring dimension "R"	S	T
25	85	40	29	42.5	33	16	36.5	58	23	4-M12	15	22	20	JIS B2401 P16 Hs90	13	3-JIS B2401 P10 Hs90	130	147
32	100	50	35	50	41	17	44	70	27.5	4-M16	16	28	26	JIS B2401 P22 Hs90	14	3-JIS B2401 P10A Hs90	140	155

● LU²⁵/₃₂FA^A/_B

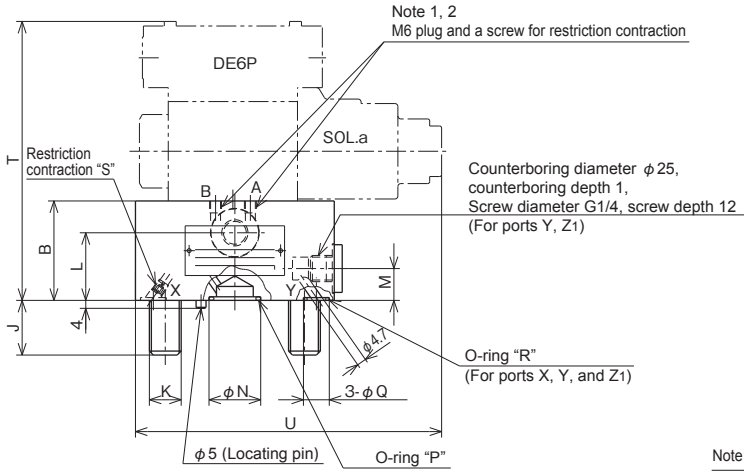
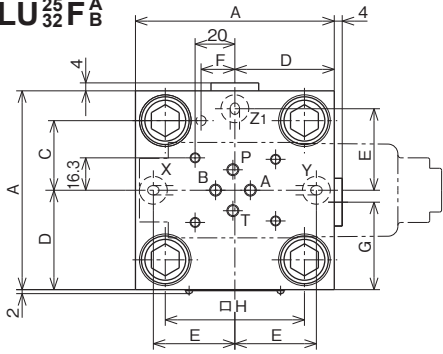

● Hydraulic symbols

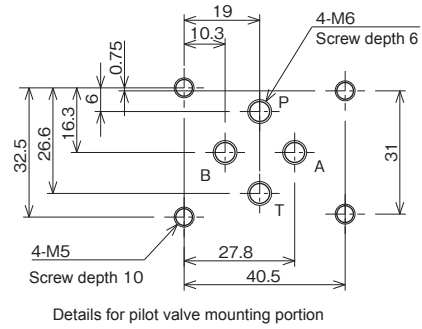
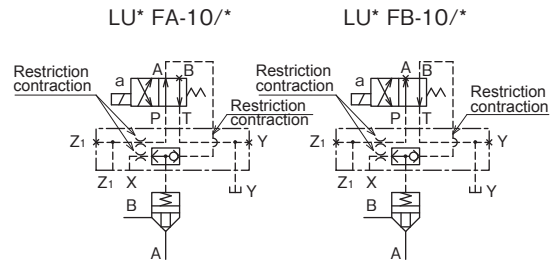

Note1. For type LU²⁵/₃₂ FA-10/*, a hexagon socket head cap set screw (M6) is provided to B port.

Note2. For type LU²⁵/₃₂ FB-10/*, a hexagon socket head cap set screw (M6) is provided to A port.

Nominal dimension	A	B	C	D	E	F	G	H	J	K	L	M	N	O-ring dimension "P"	Q	O-ring dimension "R"	S	T	U
25	85	40	29	42.5	33	16	36.5	58	23	4-M12	16	15	20	JIS B2401 P16 Hs90	13	JIS B2401 P10 Hs90	Fixed restriction contraction M6- $\phi 1.5$	130	147
32	100	50	35	50	41	17	44	70	27.5	4-M16	34	16	26	JIS B2401 P22 Hs90	14	JIS B2401 P10A Hs90	Restriction contraction M6- $\phi 1$	140	155

● LU40A

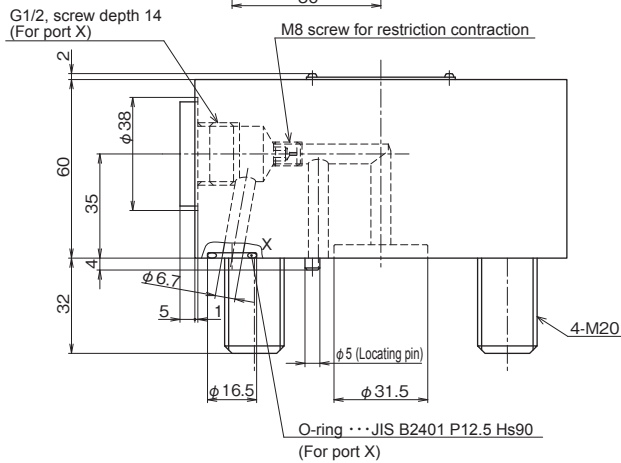
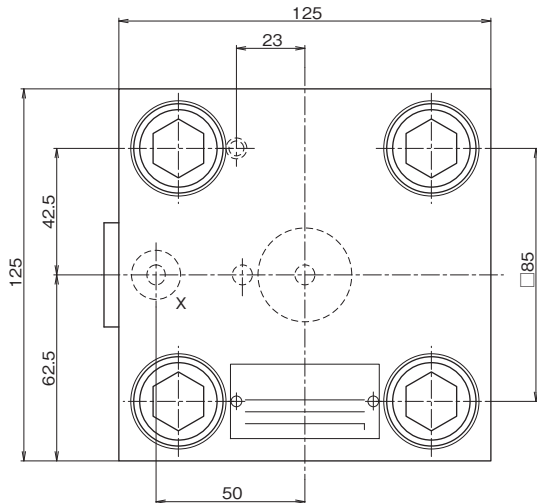

● Hydraulic symbols

LU40A-10/F*

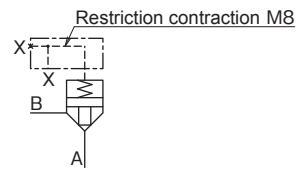

● LU40S

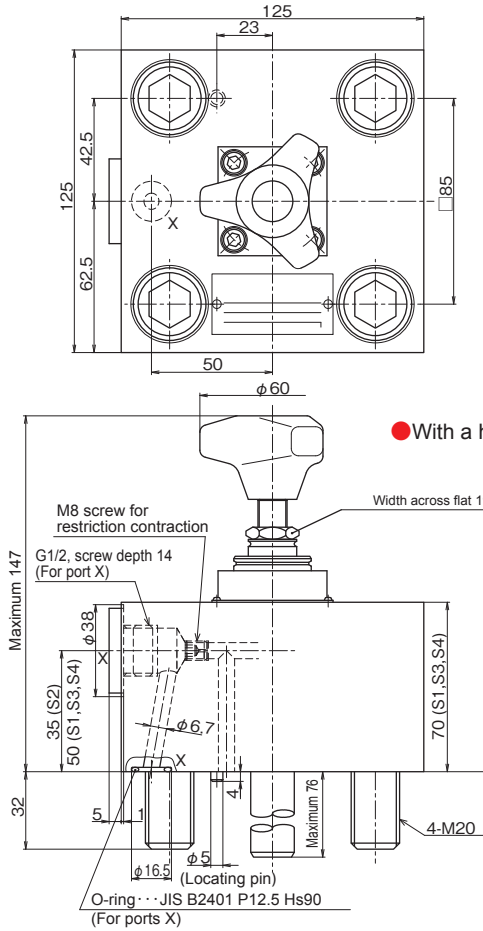

● Hydraulic symbols

LU40S¹/₄-10/F*

Restriction contraction M8

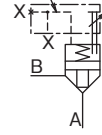

● With a handle type stroke limiter

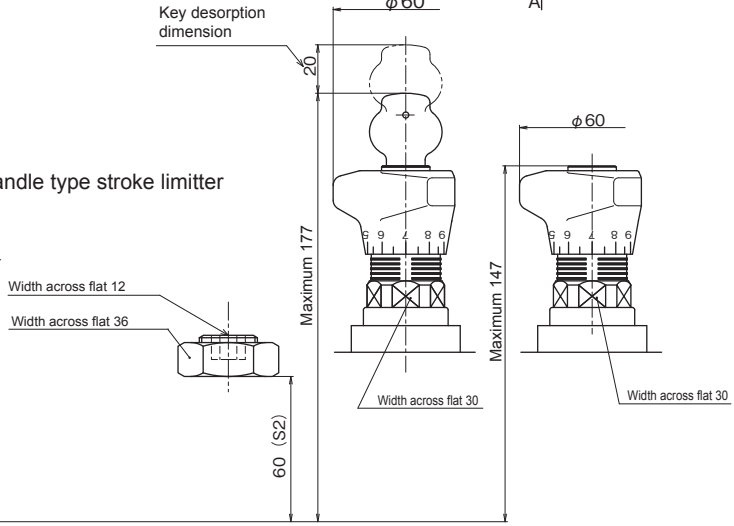

● Screw type ● Scale type with key ● Scale type

● LU40B

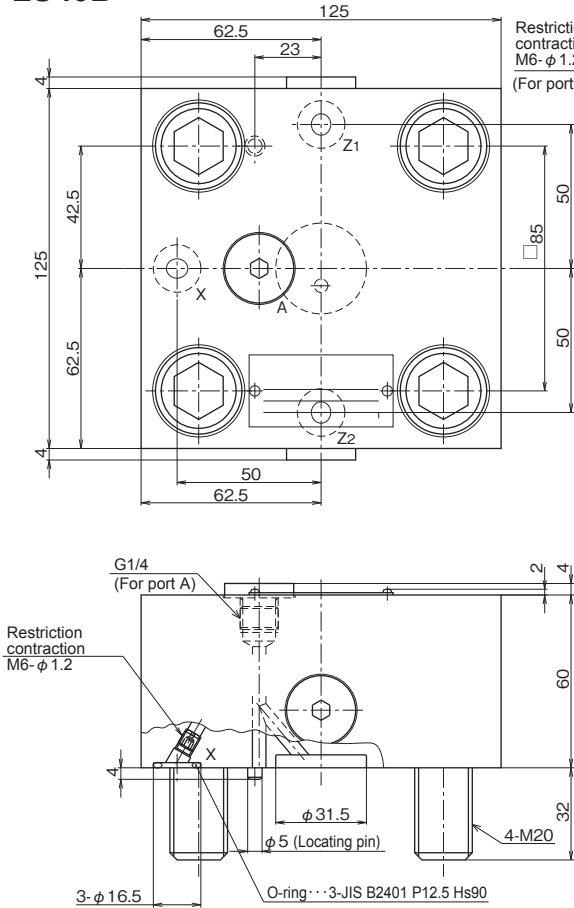

● Hydraulic symbols

LU40B

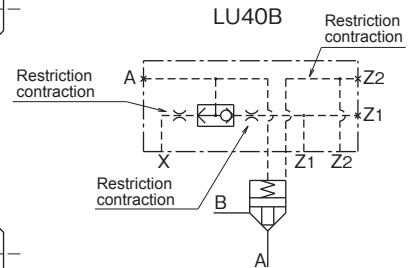

G1/4
Counterboring diameter φ25
Counterboring depth 1
Screw depth 12
(For ports A, Z1, and Z2)

● LU40C

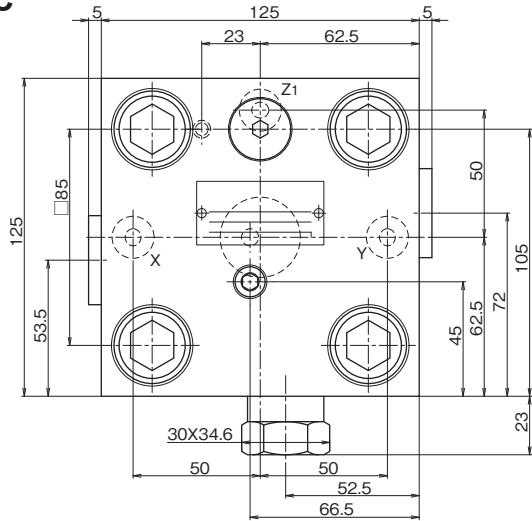

● Hydraulic symbols

LU40C

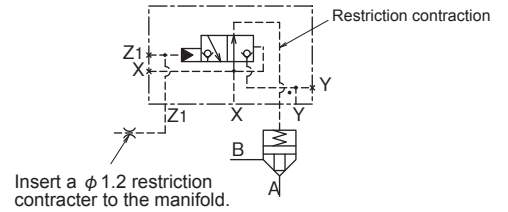

● Pilot area ratio

$$\frac{AZ_1}{AX} = \frac{3}{1}$$

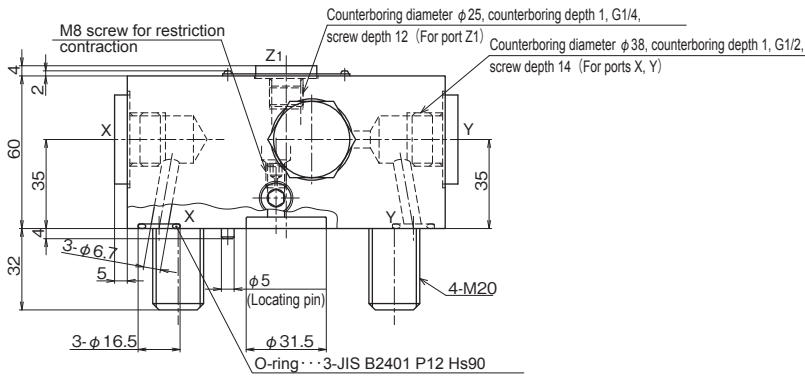

● LU40D^B

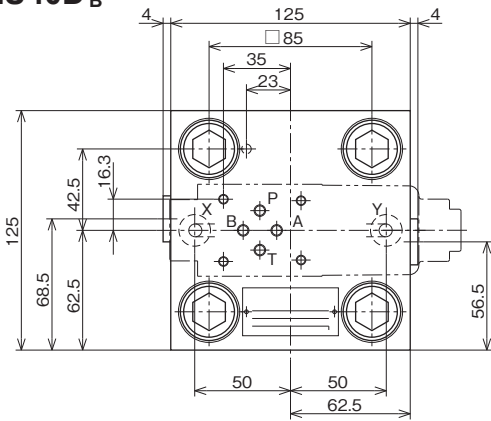

● Hydraulic symbols

LU40DA-10*

LU40DB-10*

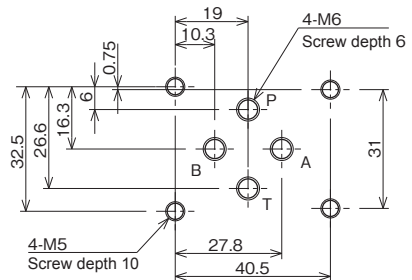
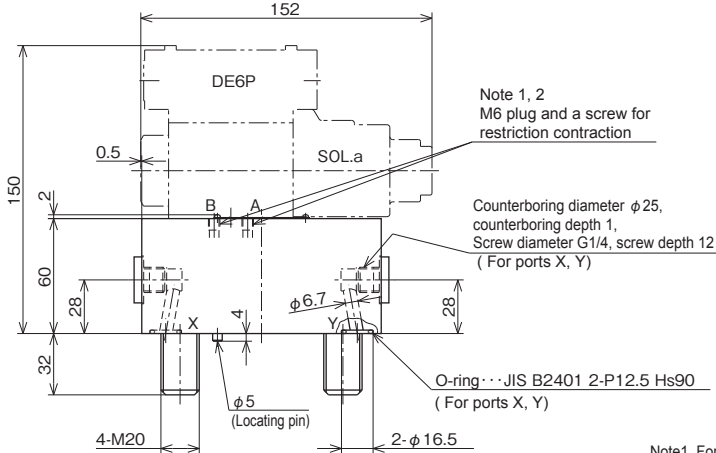
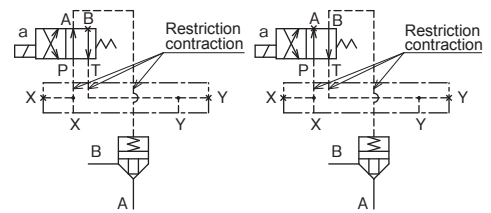

Details for pilot valve mounting portion

Note1. For type LU40DA-10*, a hexagon socket head cap set screw (M6) is provided to B port.

Note2. For type LU40DB-10*, a hexagon socket head cap set screw (M6) is provided to A port.

● LU40E_A_B

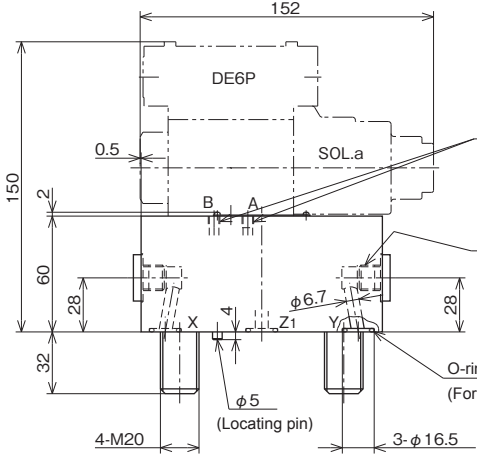
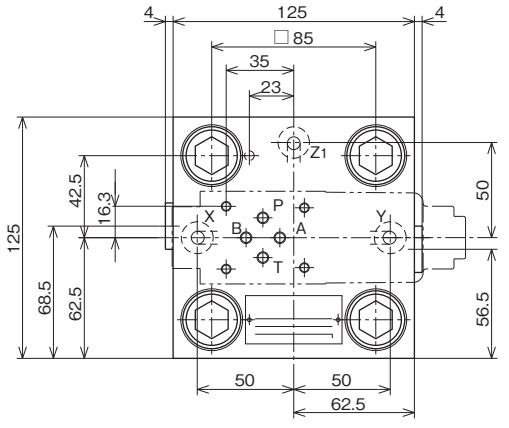

Note 1, 2
M6 plug and a screw for restriction

Counterboring diameter φ25, counterboring depth 1, G1/4, screw depth 12 (For ports X, Y)

O-ring ··· JIS B2401 3-P12.5 Hs90 (For ports X, Y, and Z1)

● Hydraulic symbols

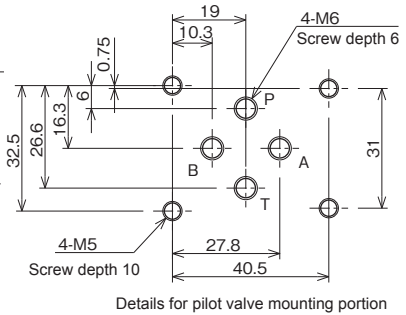
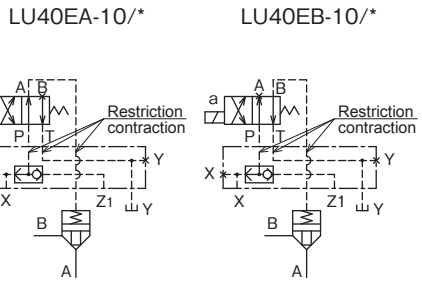

Note1. For type LU40EA-10/*, a hexagon socket head cap set screw (M6) is provided to B port.
Note2. For type LU40EB-10/*, a hexagon socket head cap set screw (M6) is provided to A port.

● LU40F_A_B

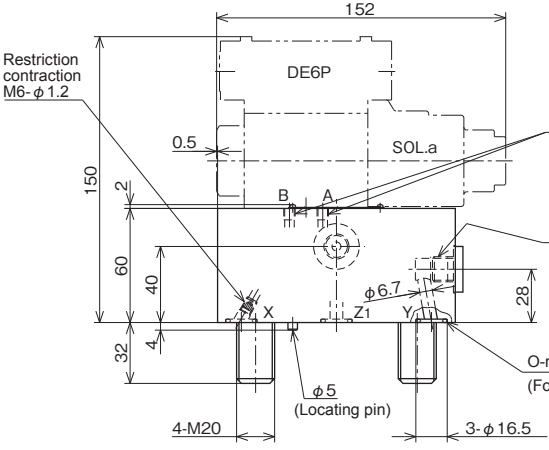
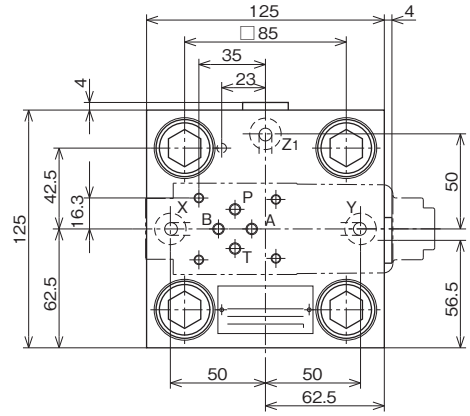

Note 1, 2
M6 plug and a screw for restriction contraction

Counterboring diameter φ25, counterboring depth 1, G1/4, screw depth 12 (For ports Y, Z1)

O-ring ··· JIS B2401 3-P12.5 Hs90 (For ports X, Y, Z1)

● Hydraulic symbols

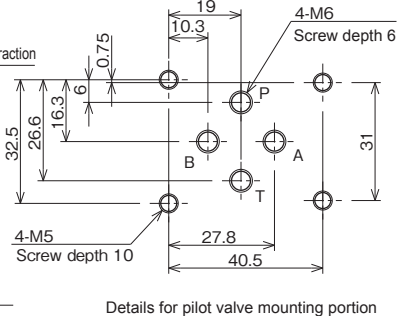
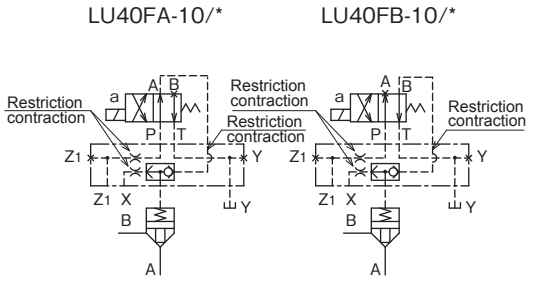

Note1. For type LU40FA-10/*, a hexagon socket head cap set screw (M6) is provided to B port.
Note2. For type LU40FB-10/*, a hexagon socket head cap set screw (M6) is provided to A port.

● LU⁵⁰₆₃A

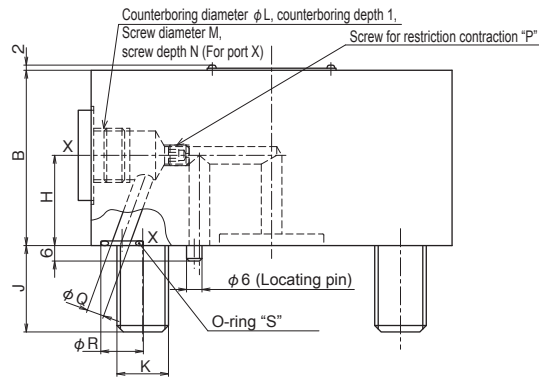
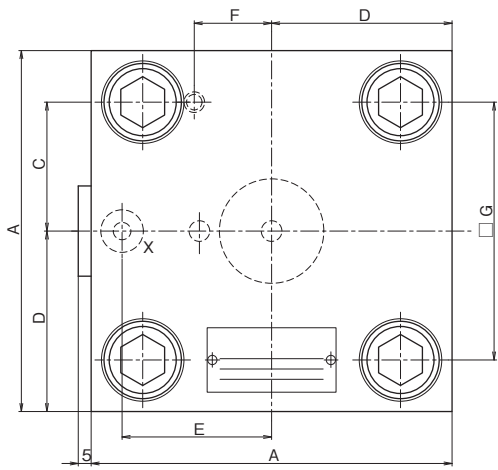

● Hydraulic symbols

LU*A-10/F

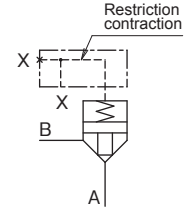

Nominal dimension	A	B	C	D	E	F	G	H	J	K	L	M	N	P	Q	R	O-ring dimension "S"
50	140	68	50	70	58	30	100	35	33.5	4-M20	38	G $\frac{1}{2}$	14	M8	6.7	16.5	JIS B2401 P12.5 Hs90
63	180	82	62.5	90	75	38	125	40	49	4-M30	45	G $\frac{3}{4}$	16	M16	11.5	22	JIS B2401 P18 Hs90

● LU⁵⁰₆₃S

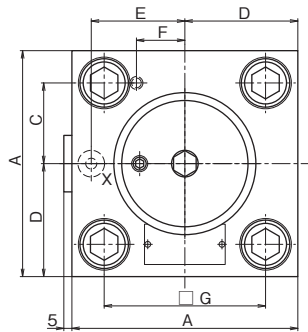

● Hydraulic symbols

LU*S₂⁴-10/F

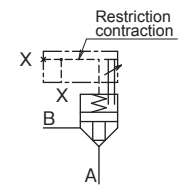

Width across flat of hexagon socket 5
(For a locking bolt)

● With a scale type stroke limiter

Counterboring diameter ϕL , counterboring depth 1,
Screw diameter M, screw depth N
(For port X)

Screw for restriction contraction "P"

O-ring "S"
(For port X)

$\phi 6$ (Locating pin)

● Screw type

Width across flat of hexagon socket W

Width across flat X

Nominal dimension	A	B	C	D	E	F	G	H	J	K	L	M	N	P	Q	R	O-ring dimension "S"	T	U	V	W	X
50	S2	140	78	50	70	58	30	100	40	4-M20	38	G $\frac{1}{2}$	14	M8	6.7	16.5	JIS B2401 P12.5 Hs90	92	15	20	17	46
63	S2	180	92	62.5	90	75	38	125	49	4-M30	45	G $\frac{3}{4}$	16	M16	11.5	22	JIS B2401 P18 Hs90	117	19	24	19	55

● LU50B

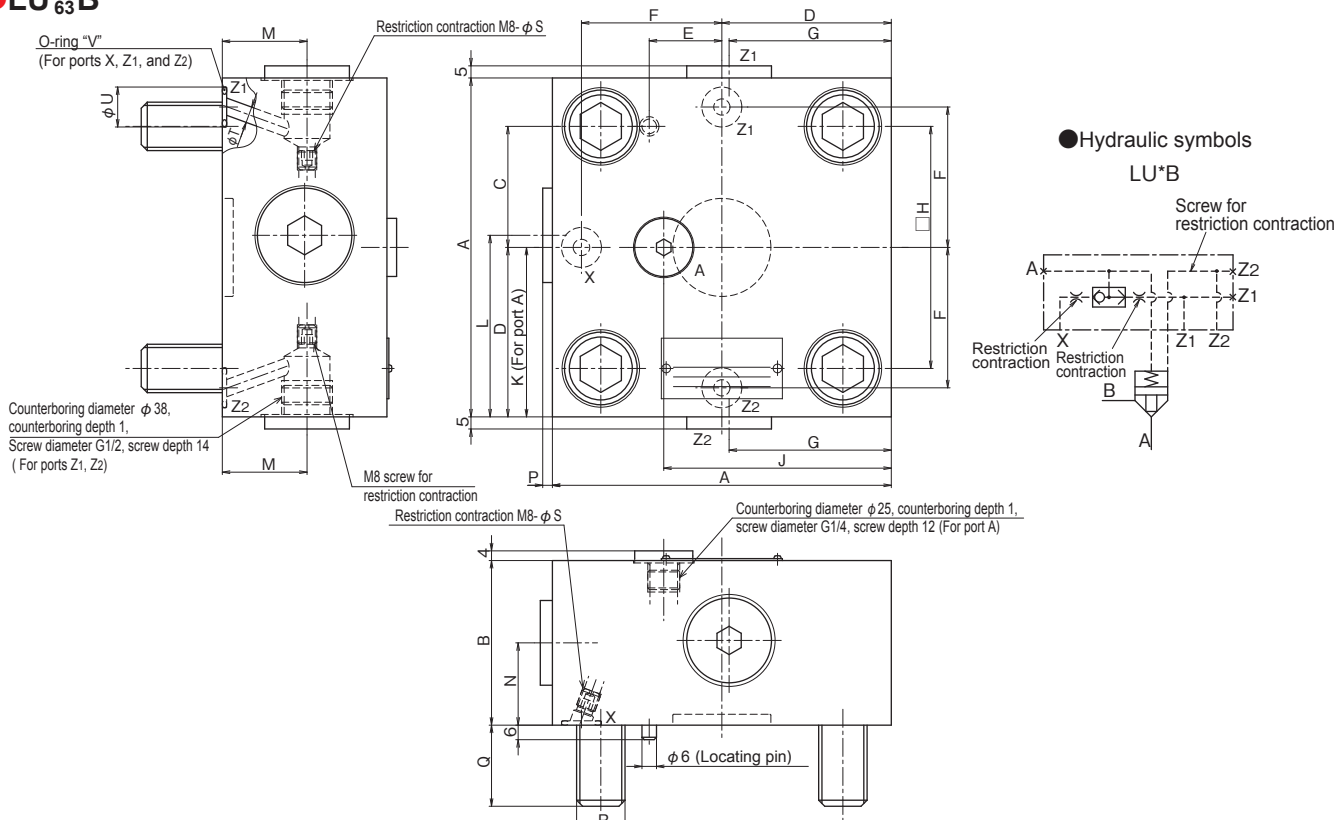

Nominal dimension	A	B	C	D	E	F	G	H	J	K	L	M	N	P	Q	R	S	T	U	O-ring dimension "V"
50	140	68	50	70	30	58	67	100	94	70	75	35	34	4	33.5	4-M20	1.5	6.7	16.5	3-JIS B2401 P12.5 Hs90
63	180	82	62.5	90	38	75	90	125	132	85	90	42	40	2	49	4-M30	1.8	11.5	22	3-JIS B2401 P18 Hs90

● LU50C

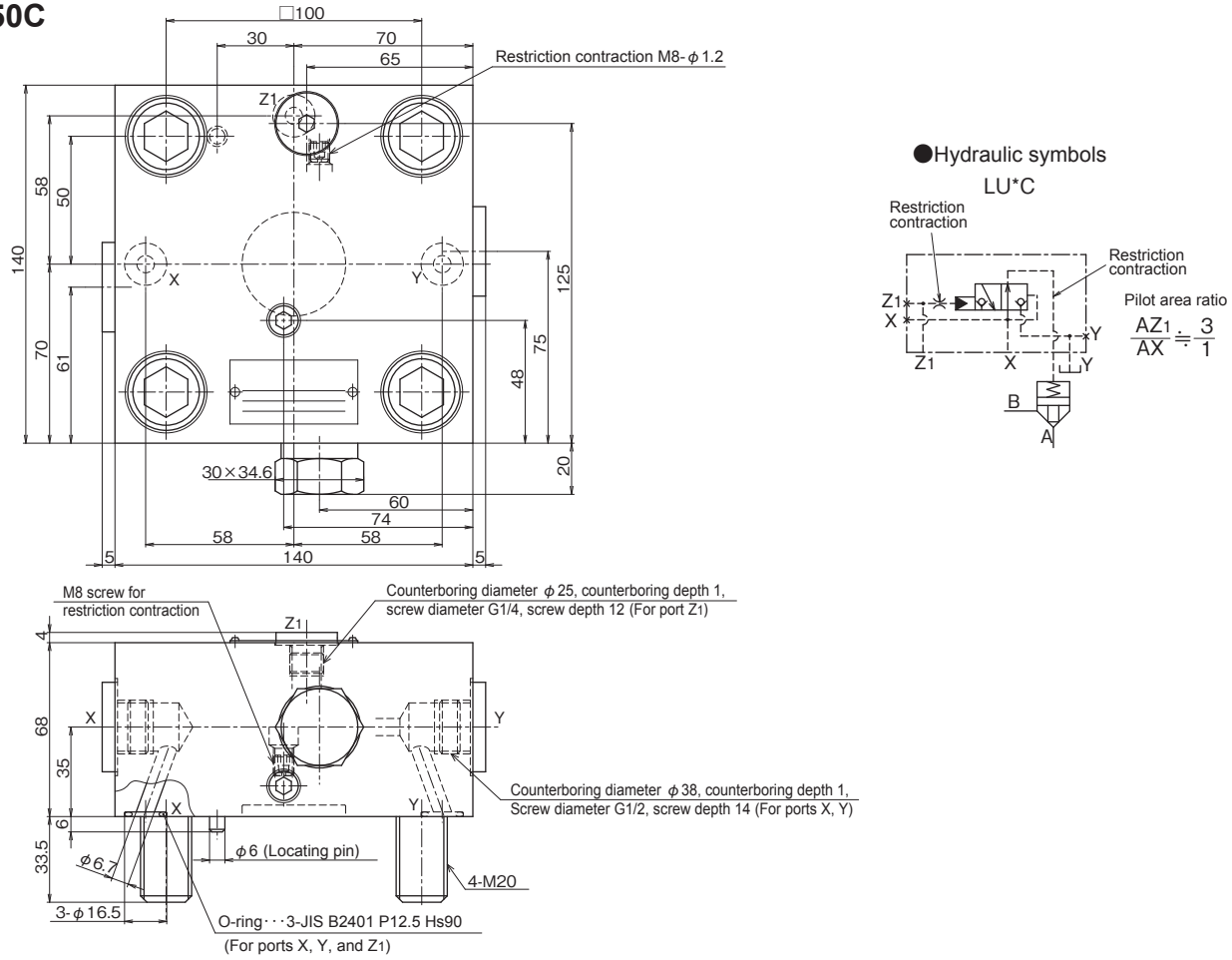

● LU⁵⁰₆₃EA^B

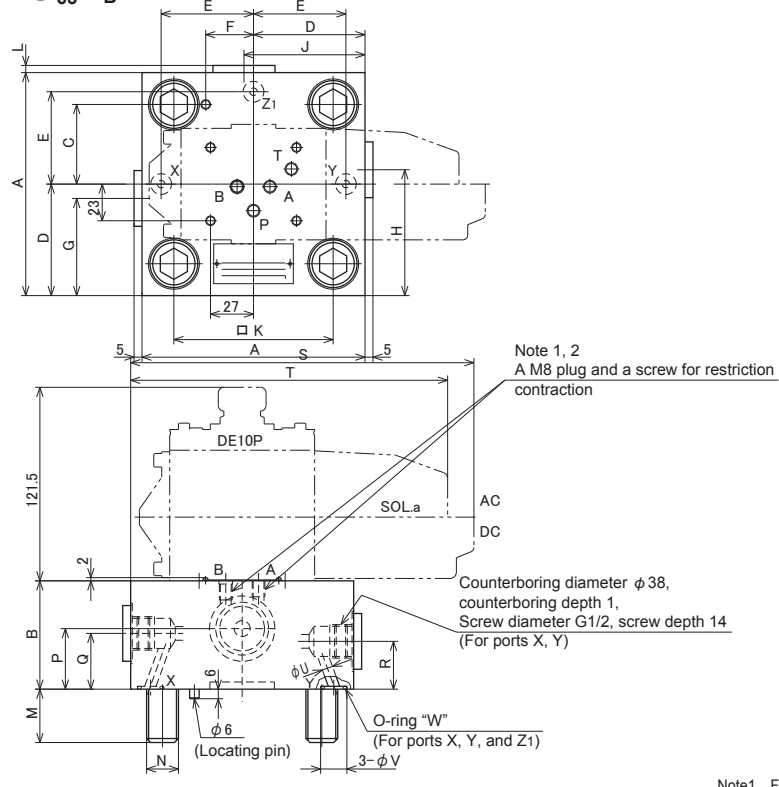

● Hydraulic symbols

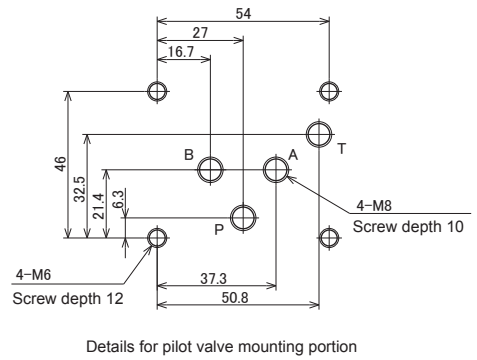
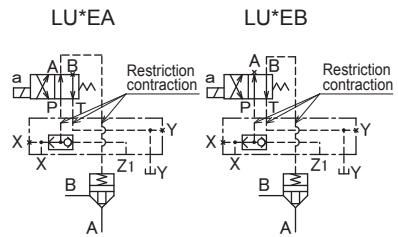

Note1. For type LU⁵⁰₆₃EA-10/*, a hexagon socket head cap set screw (M8) is provided to B port.
 Note2. For type LU⁵⁰₆₃EB-10/*, a hexagon socket head cap set screw (M8) is provided to A port.

Nominal Dimension	A	B	C	D	E	F	G	H	J	K	L	M	N	P	Q	R	S	T	U	V	O-ring dimensions "W"
50	140	68	50	70	58	30	66.5	76	76	100	4.5	34	4-M20	38	35	30	215.5	199	6.7	16.5	3-JIS B2401 P12.5 Hs90
63	180	82	62.5	90	75	38	90	96	90	125	2	50	4-M30	42	40	40	235.5	219	11.5	22	3-JIS B2401 P18 Hs90

● LU⁵⁰₆₃FA^B

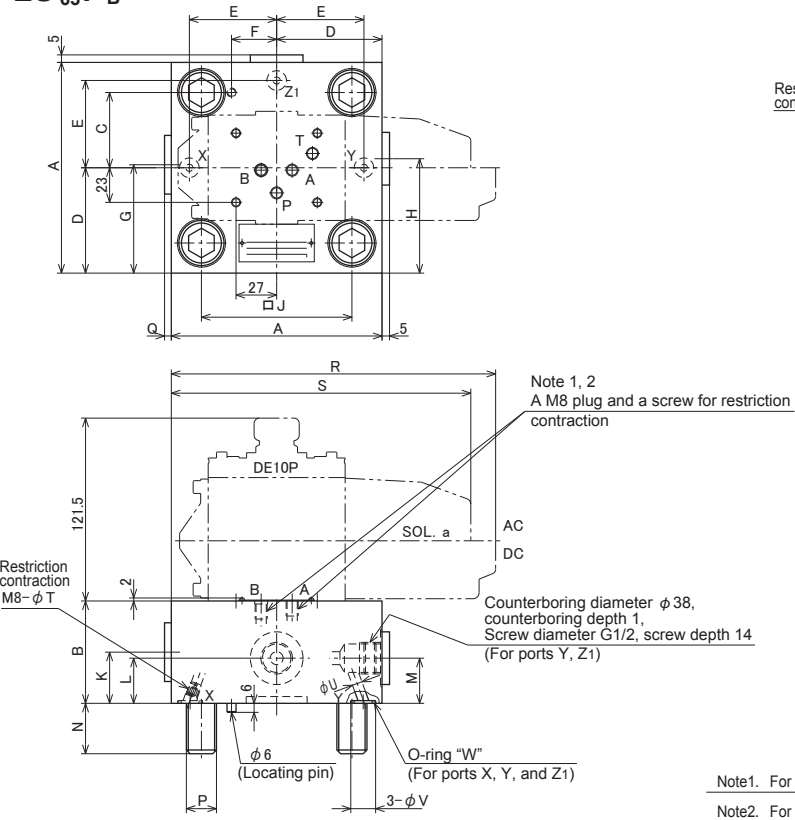

● Hydraulic symbols

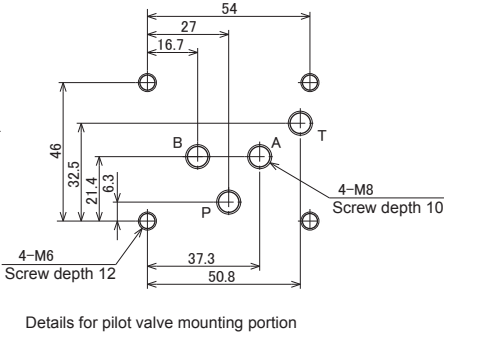
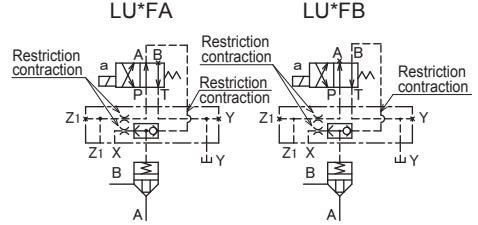

Note1. For type LU⁵⁰₆₃FA-10/*, a hexagon socket head cap set screw (M8) is provided to B port.
 Note2. For type LU⁵⁰₆₃FB-10/*, a hexagon socket head cap set screw (M8) is provided to A port.

Nominal Dimension	A	B	C	D	E	F	G	H	J	K	L	M	N	P	Q	R	S	T	U	V	O-ring dimension "W"
50	140	68	50	70	58	30	72	76	100	34	30	30	33.5	4-M20	4	215.5	199	1.5	6.7	16.5	3-JIS B2401 P12.5 Hs90
63	180	82	62.5	90	75	38	90	96	125	47	32	40	49	4-M30	1	235.5	219	1.8	11.5	22	3-JIS B2401 P18 Hs90

● LU⁸⁰₁₀₀A

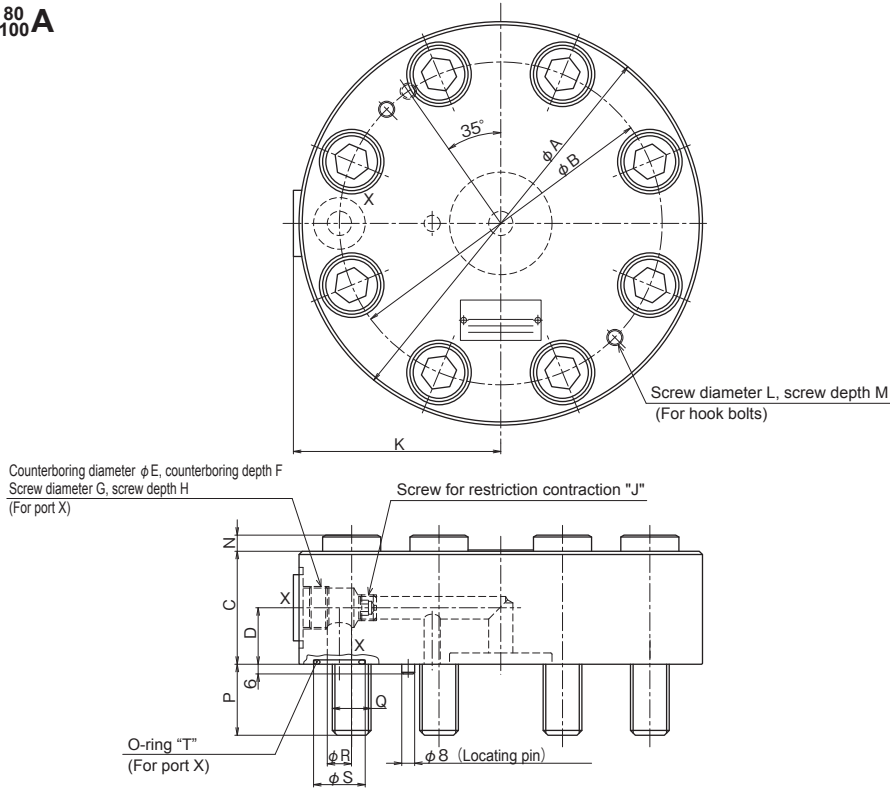

● Hydraulic symbols

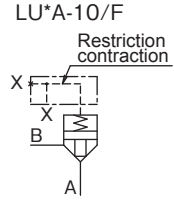

Nominal dimension	A	B	C	D	E	F	G	H	J	K	L	M	N	P	Q	R	S	O-ring dimension "T"
80	250	200	70	35	50	2.5	G $\frac{3}{4}$	16	M16	128.5	2-M10	20	10	44	8-M24	15	32	JIS B2401 P26 Hs90
100	300	245	75	40	60	4	G1	18	M20	155	2-M16	30	11	44	8-M30	18.5	40	JIS B2401 P34 Hs90

● LU⁸⁰₁₀₀S

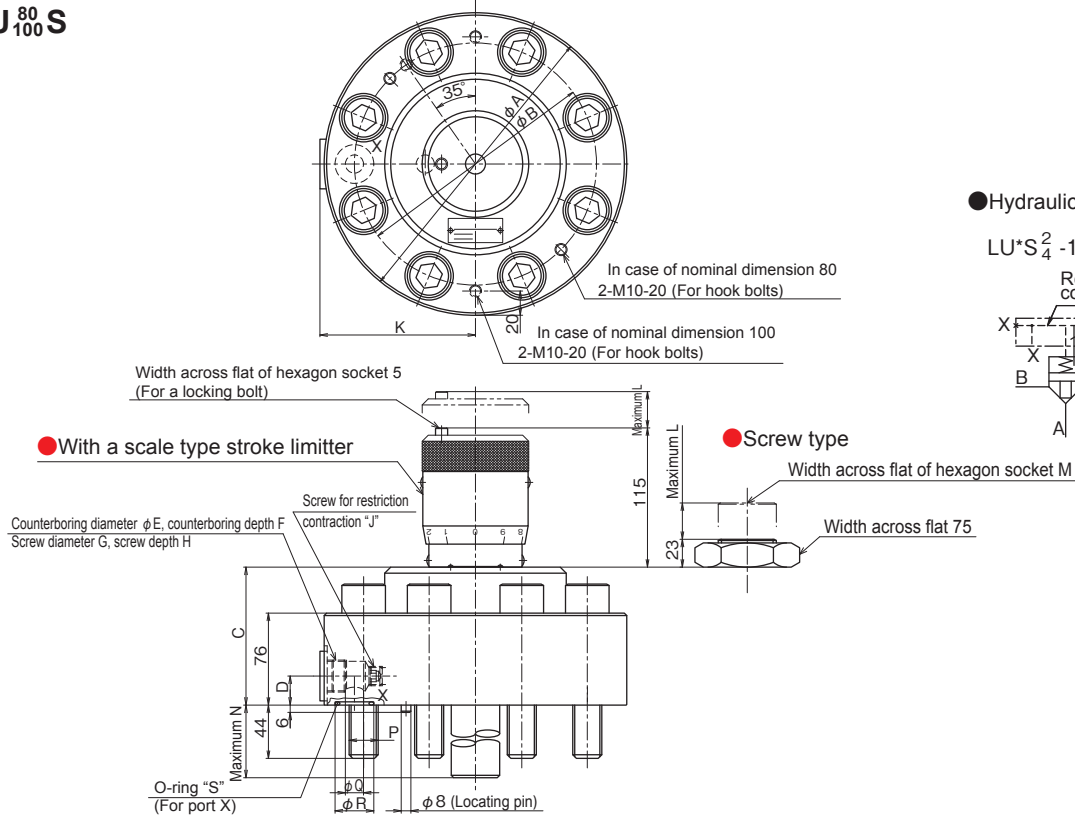

● Hydraulic symbols

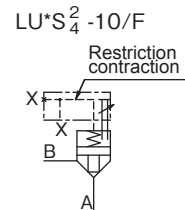

Nominal dimension	A	B	C	D	E	F	G	H	J	K	L	M	N	P	Q	R	S	O-ring dimension "S"
80	S2 S4	250	200	114 35 24	50	2.5	G $\frac{3}{4}$	16	M16	128.5	30	24	143	8-M24	15	32		JIS B2401 P26 Hs90
100	S2 S4	300	245	132 40 35	60	4	G1	18	M20	155	38	27	178	8-M30	18.5	40		JIS B2401 P34 Hs90

● LU80B

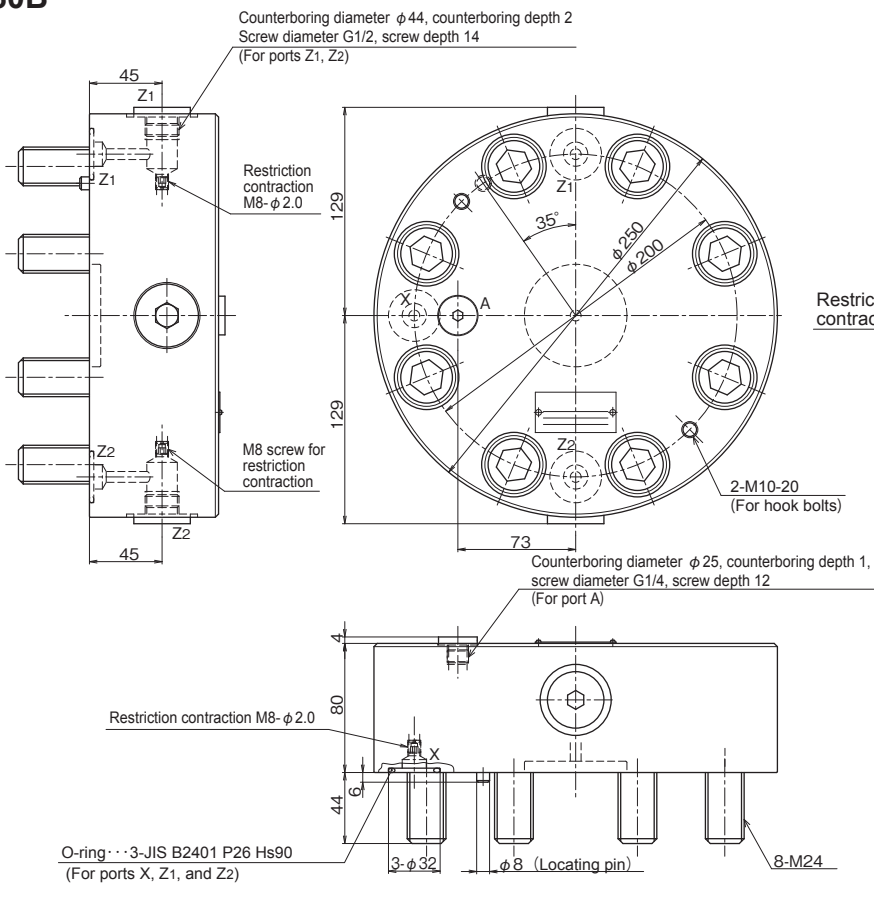

● Hydraulic symbols

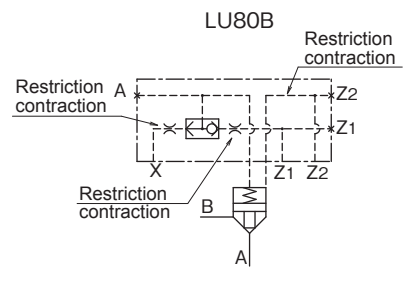

● LU100B

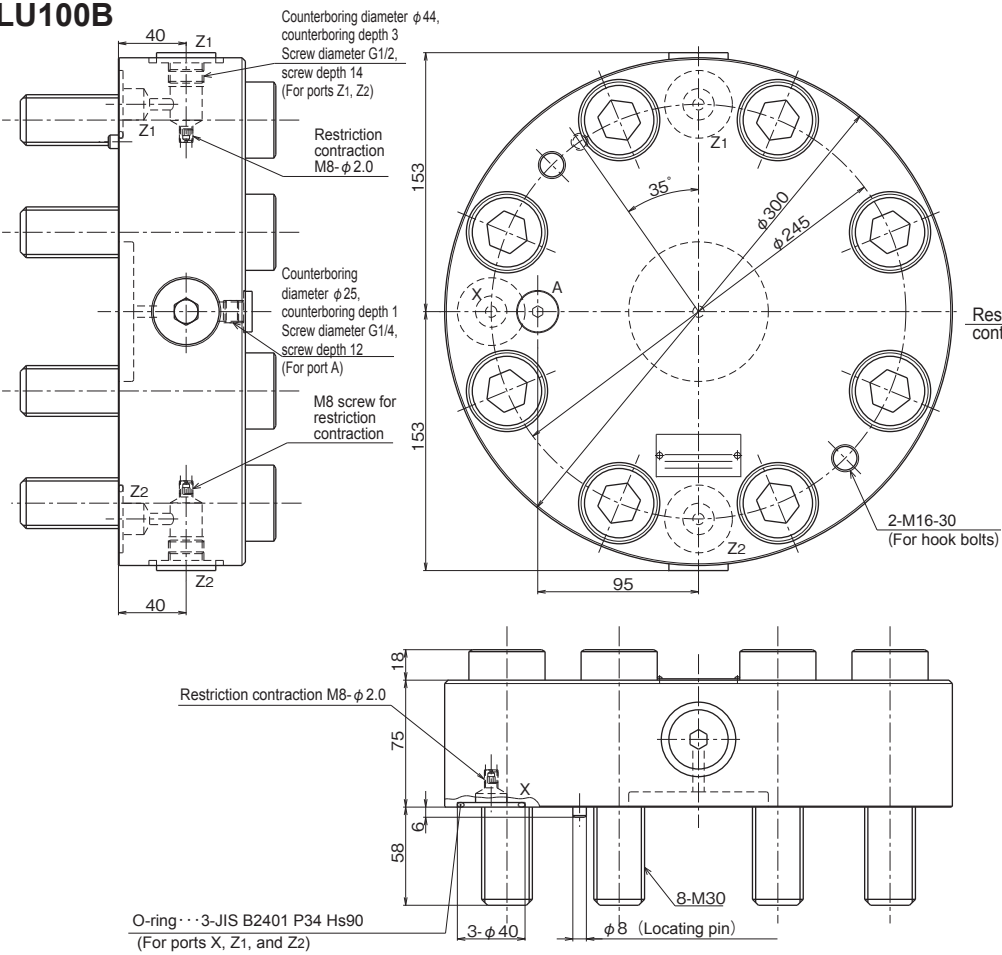

● Hydraulic symbols

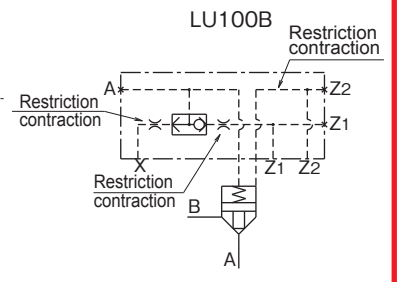

LU⁸⁰₁₀₀C

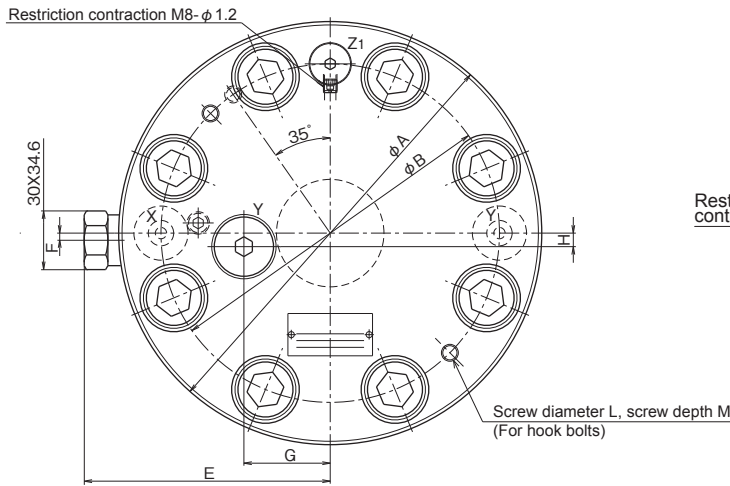

●Hydraulic symbols
LU*C

Pilot area ratio
 $\frac{AZ1}{AX} = \frac{3}{1}$

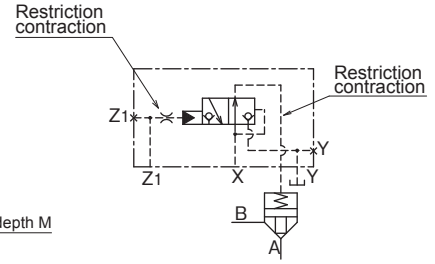

Counterboring diameter φ 38, counterboring depth 1,
Screw diameter G1/2, screw depth 14
(For port Y)

Counterboring diameter φ 25, counterboring depth 1,
screw diameter G1/4, screwed depth 12
(For port Z1)

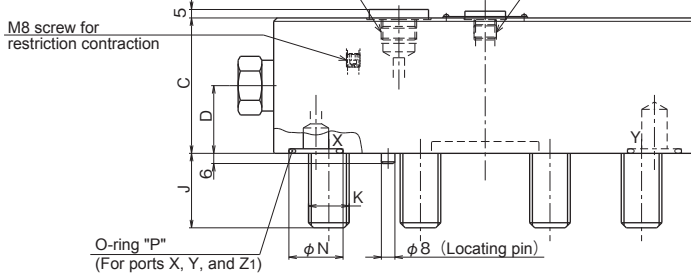

Nominal dimension	A	B	C	D	E	F	G	H	J	K	L	M	N	O-ring dimension "P"
80	250	200	80	40	146	4	51	8	44	8-M10	2-M10	20	32	3-JIS B2401 P26 Hs90
100	300	245	90	45	167	0	72	5	57	8-M30	2-M16	30	40	3-JIS B2401 P34 Hs90

LU⁸⁰₁₀₀DA_B

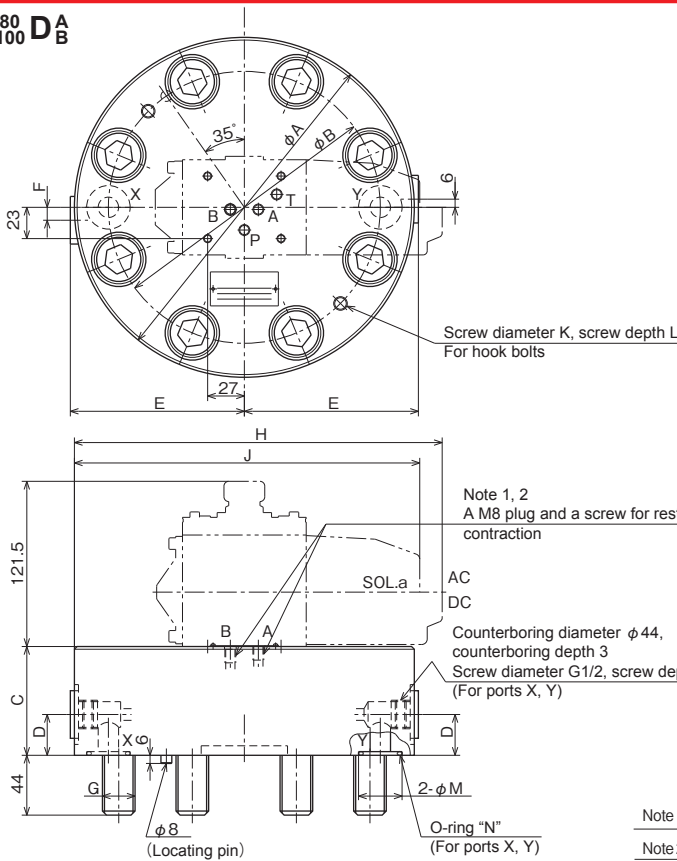

●Hydraulic symbols

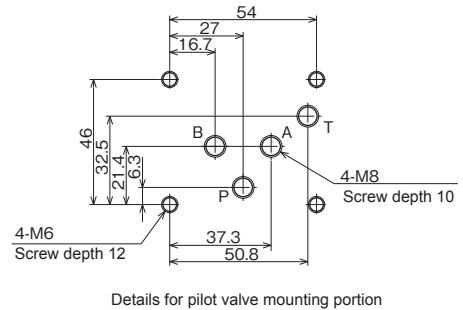
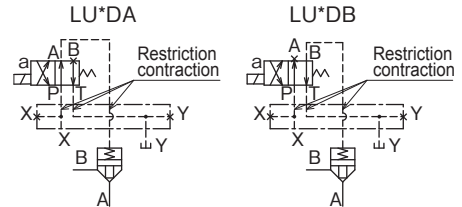

Note 1. For type LU⁸⁰₁₀₀ DA-10*, a hexagon socket head cap M8 screw (M6) is provided to B port.

Note 2. For type LU⁸⁰₁₀₀ DB-10*, a hexagon socket head cap M8 screw (M6) is provided to A port.

Nominal dimension	A	B	C	D	E	F	G	H	J	K	L	M	O-ring dimension "N"
80	250	200	80	30	128	9.5	8-M24	270.5	254	2-M10	20	32	2-JIS B2401 P26 Hs90
100	300	245	90	40	153	9	8-M30	295.5	279	2-M16	30	40	2-JIS B2401 P34 Hs90

LU⁸⁰₁₀₀ E^A_B

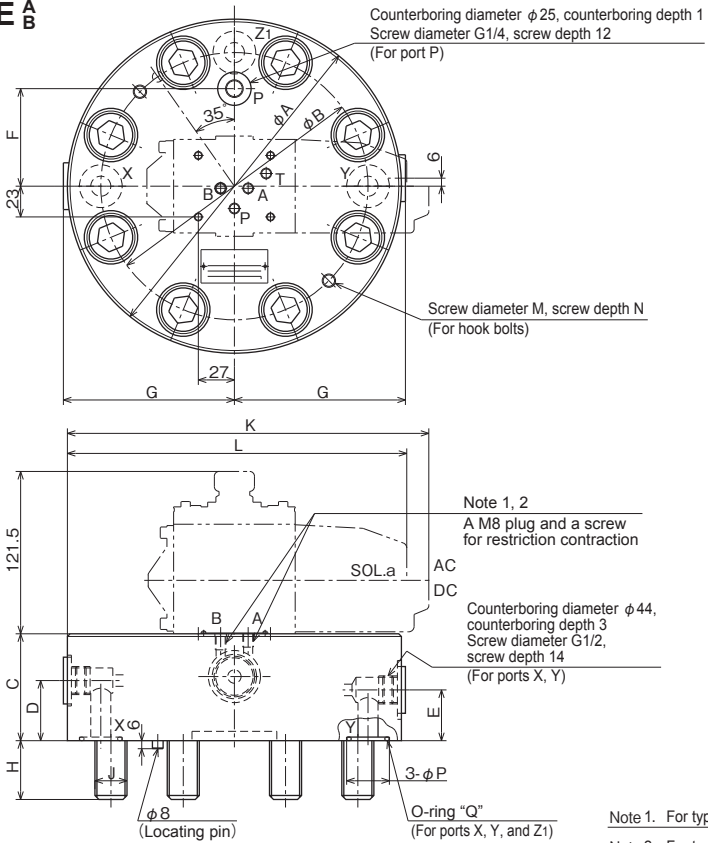

● Hydraulic symbols

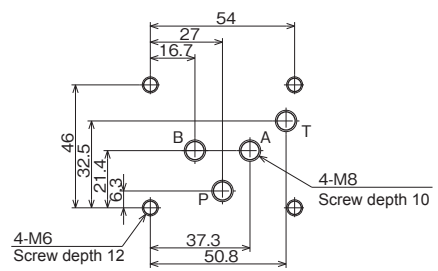
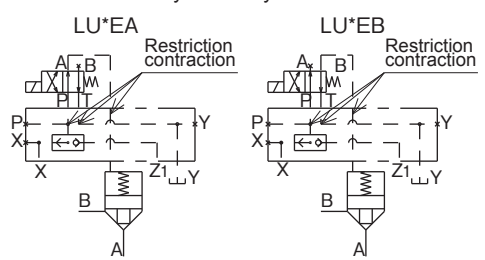

Details for pilot valve mounting portion

Note 1. For type LU⁸⁰₁₀₀EA-10/*, a hexagon socket head cap M8 screw (M6) is provided to B port.
Note 2. For type LU⁸⁰₁₀₀EB-10/*, a hexagon socket head cap M8 screw (M6) is provided to A port.

Nominal dimension	A	B	C	D	E	F	G	H	J	K	L	M	N	P	O-ring dimension "Q"
80	250	200	80	45	38	73	128	44	8-M24	270.5	254	2-M10	20	32	3-JIS B2401 P26 Hs90
100	300	245	90	55	40	95	153	57	8-M30	295.5	279	2-M16	30	40	3-JIS B2401 P34 Hs90

LU⁸⁰₁₀₀ F^A_B

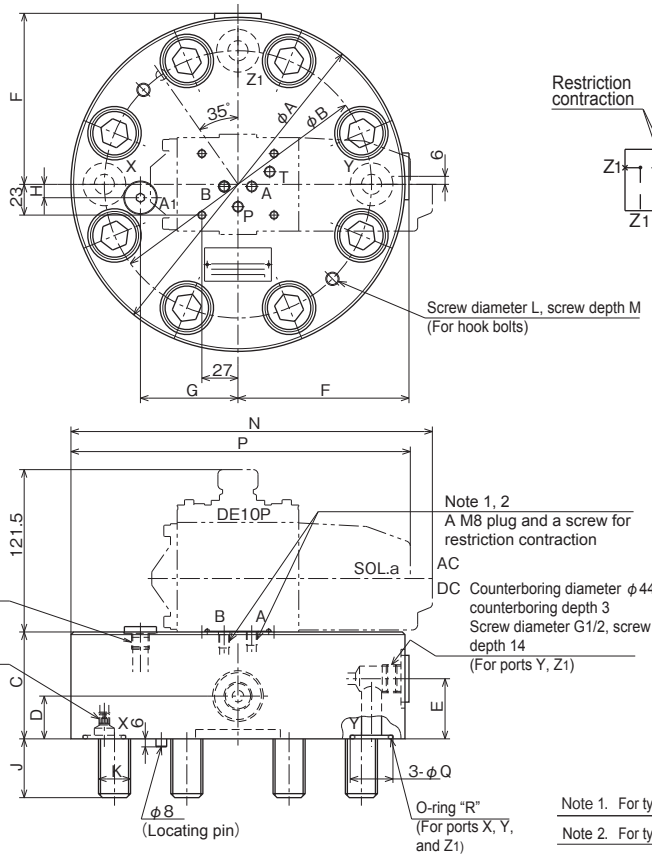

● Hydraulic symbols

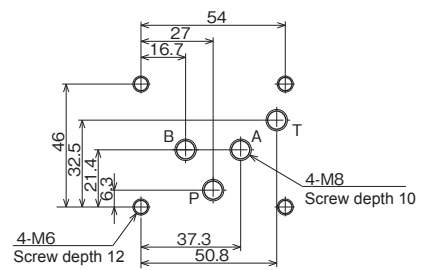
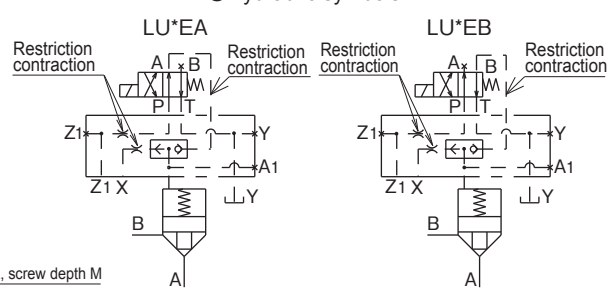

Details for pilot valve mounting portion

Note 1. For type LU⁸⁰₁₀₀FA-10/*, a hexagon socket head cap M8 screw (M6) is provided to B port.
Note 2. For type LU⁸⁰₁₀₀FB-10/*, a hexagon socket head cap set screw (M6) is provided to A port.

Nominal dimension	A	B	C	D	E	F	G	H	J	K	L	M	N	P	Q	O-ring dimension "R"
80	250	200	80	32	45	128	73	10	44	8-M24	2-M10	20	270.5	254	32	3-JIS B2401 P26 Hs90
100	300	245	90	40	40	153	95	13	57	8-M30	2-M16	30	295.5	279	40	3-JIS B2401 P34 Hs90

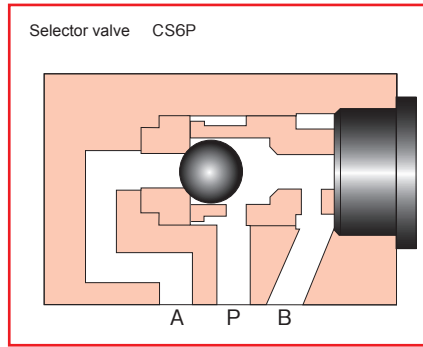
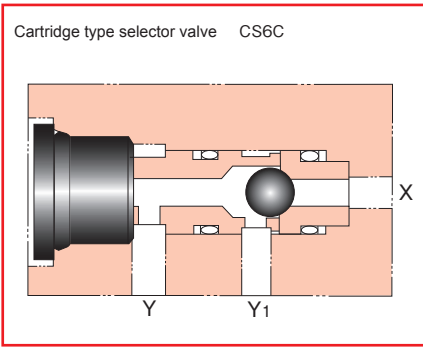

Type indication

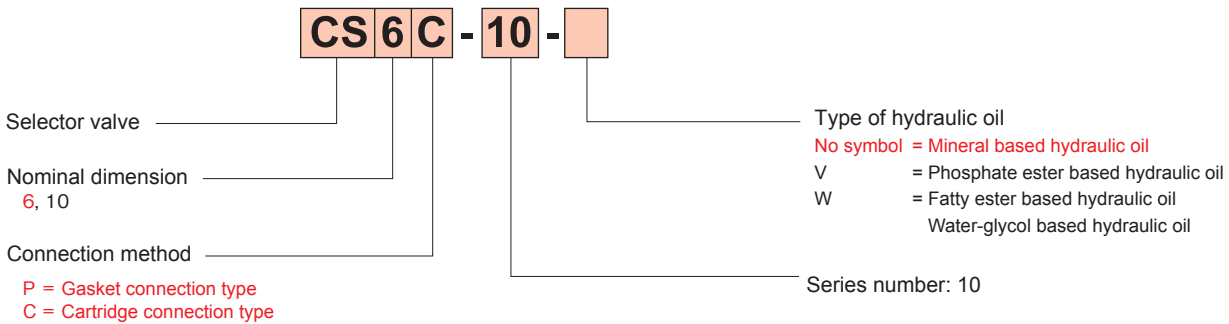

Hydraulic symbols

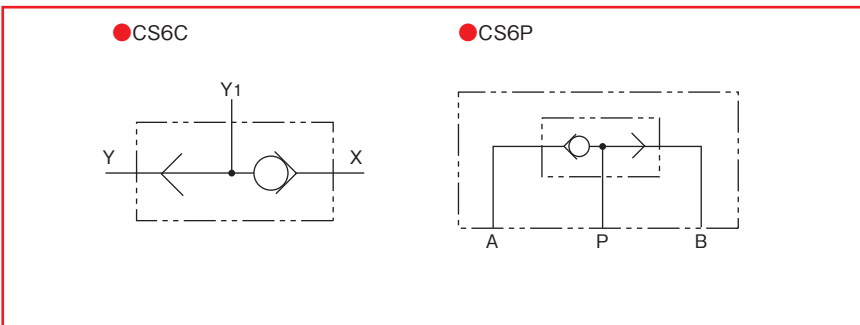

Specifications

	CS*C		CS*P	
	6	10	6	10
Nominal Dimension	6	10	6	10
Maximum working pressure MPa (kgf/cm ²)	41.2 (420)		30.9 (315)	
Maximum flow rate L/min ⁻¹	20	60	20	60
Mass kg	0.05	0.3	0.9	3.0

*1. Add restriction contraction to the manifold, if necessary, so as the flow rate to be the specified maximum value or lower even when expected maximum differential pressure is applied.

Accessories

Mounting bolt

Type	Hexagon socket head cap thread	Quantity	Tightening torque N·m (kgf·cm)
CS6P	M5×50L	4 pcs.	6.9±1.0 (70±10)
CS10P	M6×70L	4 pcs.	11.8±1.8 (120±18)

Dimension drawing

CS₁₀⁶C

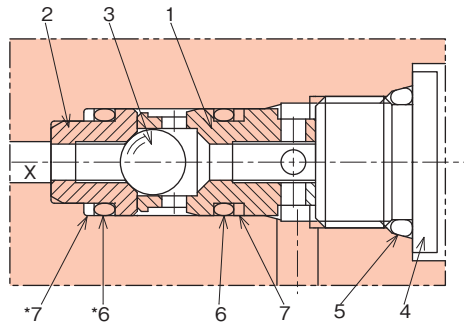

No.	Description
1	Sheet
2	Sheet
3	Steel ball
4	Plug
5	O-ring
6	O-ring
7	Backup ring

Caution for assembling
Put the backup ring *7, and O-ring *6 into the cartridge hole, and then inset the sheet 2.

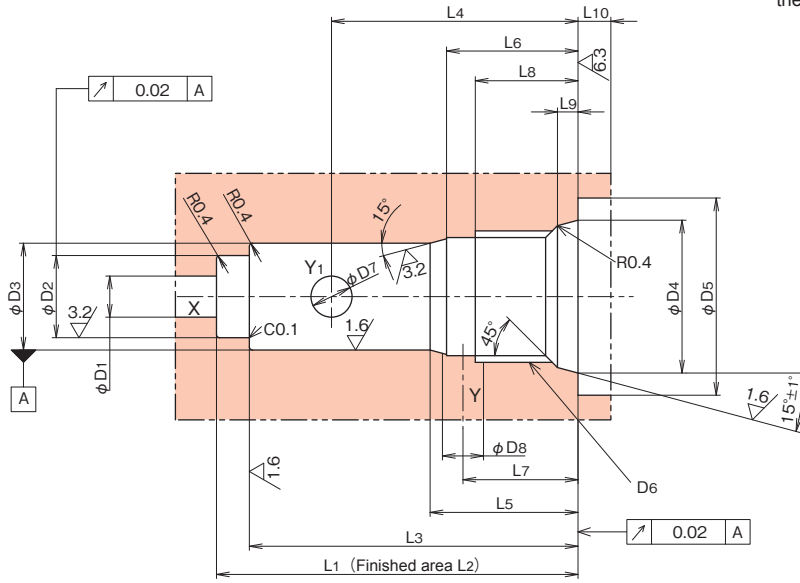

Nominal dimension	L1 ^{+0.1} ₀	L2	L3 ^{+0.2} ₀	L4	L5 ^{+0.5} ₀	L6	L7	L8	L9 ^{+0.4} ₀	L10	D1	D2	D3	D4 ^{+0.1} ₀	D5	D6	D7	D8
6	44	42.5	40	30	18	16	14	12.5	2.5	4	5	10H8 ^{+0.022} ₀	13H8 ^{+0.027} ₀	18.6	24	M16×1.5	5	5
10	65	63	61	45	26.5	24	19	16.5	3.5	4	10	22H7 ^{+0.021} ₀	28H7 ^{+0.021} ₀	35.8	41	G1	11.5	11.5

●CS6P

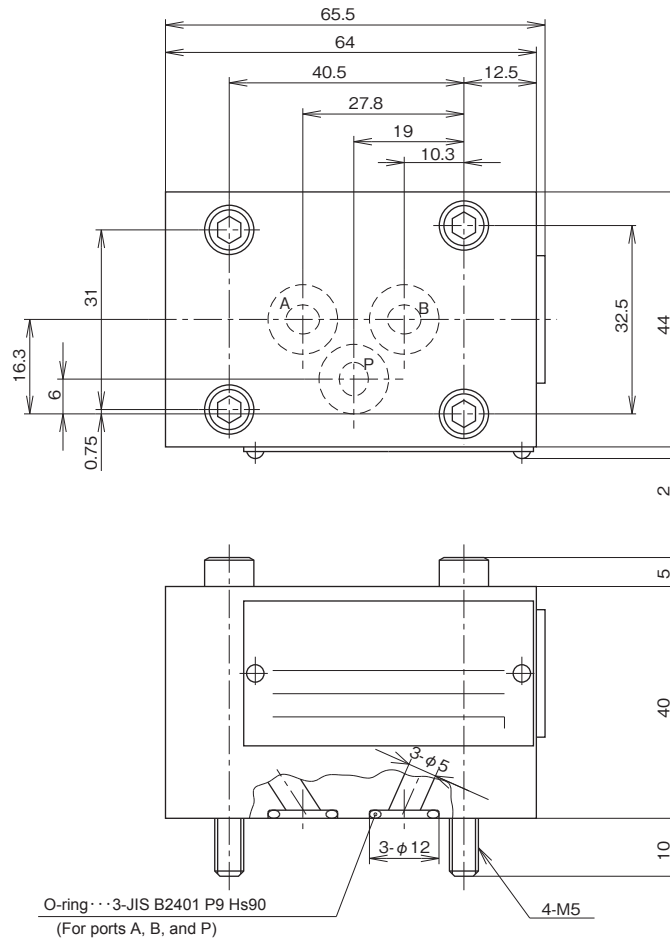

●CS10P

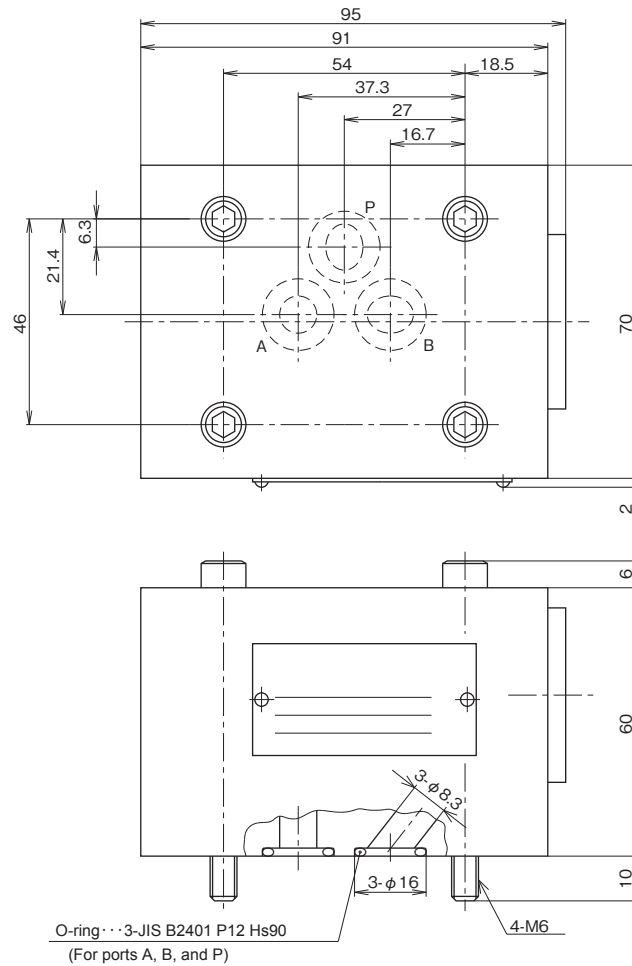

Logic element for pressure control

LR/LPR

Type indication

● LR

LR 40 C - 10 - B 20 / 15 -

Logic element (Relief valve element)

Nominal dimension: 16, 25, 32, 40, 50, 63, 80

Connection method: C = Cartridge type

Series number: 10

Poppet type: A = Types without cushion overlap, B = Types with cushion overlap

Cracking pressure: 20 = 0.2MPa(2.0kgf/cm²)

Type of hydraulic oil

- No symbol = Mineral based hydraulic oil
- Fatty ester based hydraulic oil
- Water-glycol based hydraulic oil
- V = Phosphate ester based hydraulic oil

Restriction contraction hole diameter (In case that a restriction contraction hole is provided)

Nominal Dimension	Restriction contraction hole
16	φ1.0
25	φ1.0
32	φ1.2
40	φ1.5
50	φ1.8
63	φ2.0
80	φ2.8

● LPR

LPR 40 C - 10 - B 20 -

Logic element (Pressure reducing valve element)

Nominal dimension: 16, 25, 32, 40, 50, 63

Connection method: C = Cartridge connection type

Series number: 10

Poppet type: B = Types with cushion overlap

Type of hydraulic oil

- No symbol = Mineral based hydraulic oil
- Fatty ester based hydraulic oil
- Water-glycol based hydraulic oil
- V = Phosphate ester based hydraulic oil

Cracking pressure: 20 = 0.2MPa(2.0kgf/cm²)

Specifications

Nominal Dimension	16	25	32	40	50	63	80	
Maximum working pressure MPa (kgf/cm ²)	41.2 (420)							
Maximum flow rate L/min (Note)	LR	250	400	600	1,000	1,600	2,500	4,500
	LPR	40	100	150	300	500	800	—
Sheet area cm ²	LR	1.77	3.80	6.15	11.3	16.6	26.4	44.2
	LPR	2.27	3.80	6.15	11.3	19.6	30.2	—
Poppet stroke mm	LR	6	8	10	13	16	20	23
	LPR	6.5	8.5	10	13	17	22	—
Stroke volume cm ³	LR	1.06	3.04	6.15	14.7	26.6	52.8	101.7
	LPR	1.48	3.23	6.15	14.7	33.3	66.4	—
Mass kg	0.2	0.4	1.0	1.8	3.8	7.0	13.0	

(Note) For the pressure reducing valve element, setting larger cracking pressure can increase the maximum flow rate.

Cover

We can manufacture covers for relief valve and pressure reducing valve element.

Please contact us for the detail information.

Dimension drawing (Refer to the paragraph "Logic valve" for manifold machining drawings.)

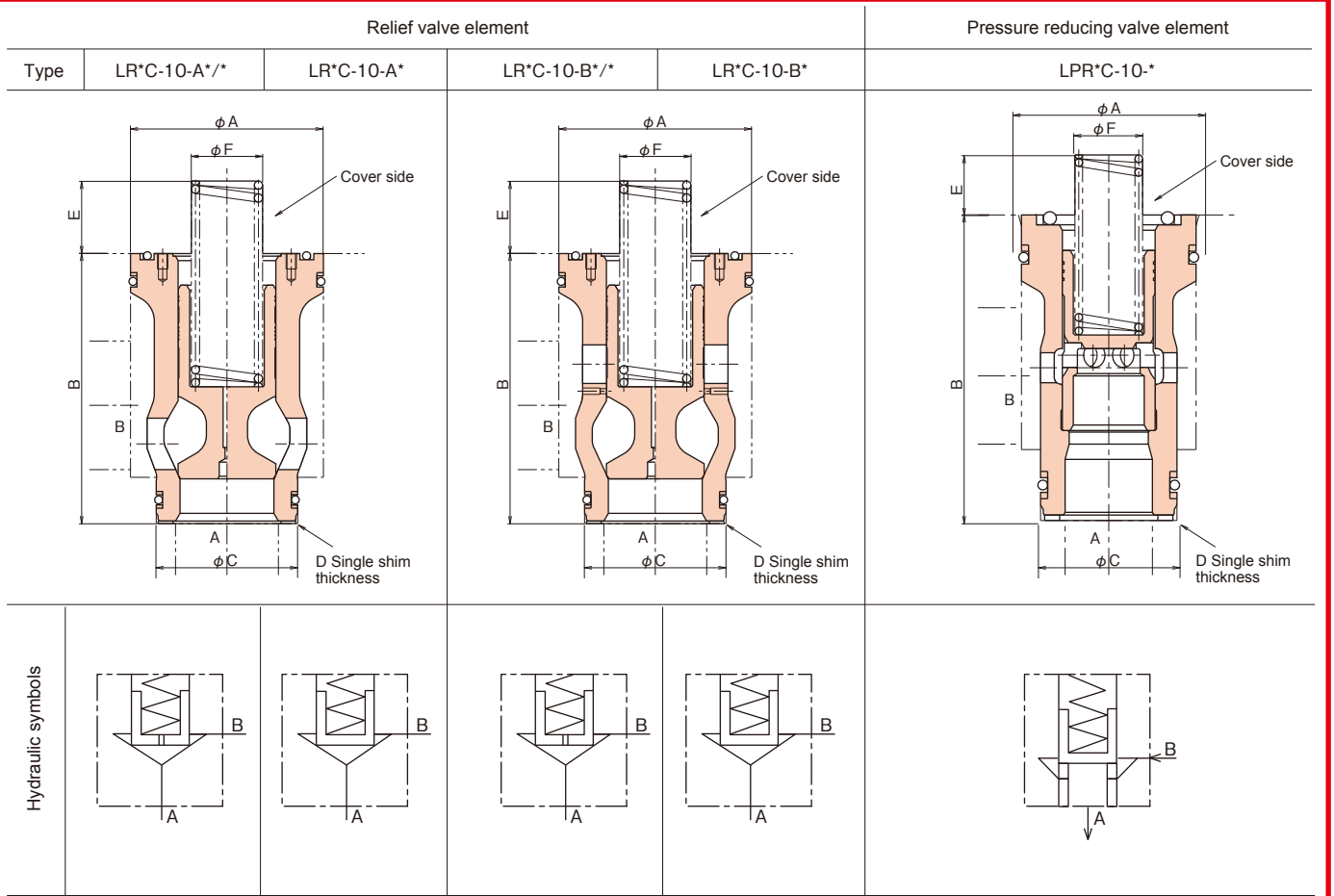

Nominal dimension	16	25	32	40	50	63	80
ϕA	32	45	60	75	90	120	145
B	55	71	84	104	121	153	203
ϕC	25	34	45	55	68	90	110
D	1	1	1	1	1	2	2
E	0	0	0	4.5	6	7	20
ϕF	0	0	0	30	38	48	60

(Note) Refer to the paragraph "Logic valve" for selecting procedure of a shim.

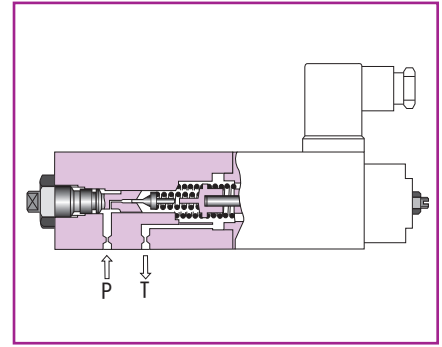
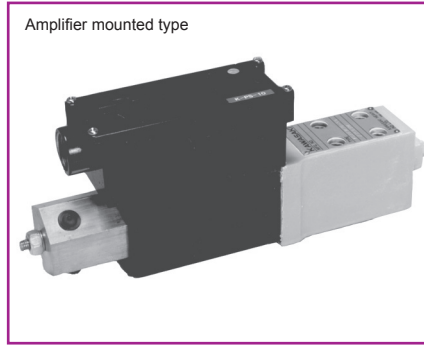
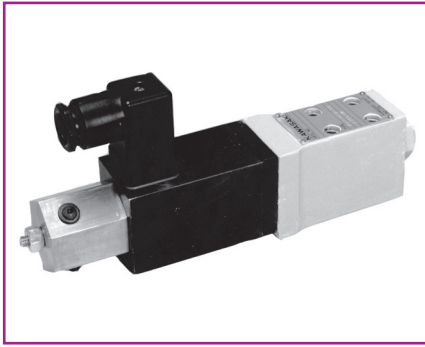

Overview

The solenoid proportional direct operated type relief valve consists of DC proportional solenoid and poppet type direct operated relief valve, and allows hydraulic pressure to be remotely controlled at a given rate in proportion to the input current by connecting it to the vent line of the pilot operation type pressure control valve (relief valve or pressure reducing valve). In addition, amplifier mounted types are controlled by voltage input.

Features

1. Special damping mechanism with a spring realises superior stability even at high pressure of 34.3 MPa (350 kgf/cm²).
2. During the initial adjustment or malfunction in the electrical system, manual operation can be done with the manual pressure adjustment thread.
3. The structure is simple and maintenance is easy.
4. Easy handling amplifier mounted type is also lined up.

Hydraulic symbols

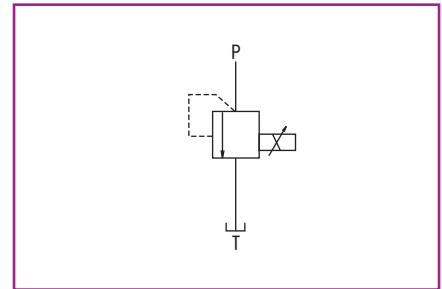

Type indication

RDPV5P-10/350-EC- []

Solenoid proportional direct operated type relief valve (For vent control)

Nominal dimension
5

Connection method
P = Gasket connection type

Series number: 10

Highest adjustment pressure

- 50 = 4.9MPa (50kgf/cm²)
- 100 = 9.8MPa (100kgf/cm²)
- 150 = 14.7MPa (150kgf/cm²)
- 250 = 24.5MPa (250kgf/cm²)
- 315 = 30.9MPa (315kgf/cm²)
- 350 = 34.3MPa (350kgf/cm²)

Type of hydraulic oil

- No symbol = Mineral based hydraulic oil
- V = Phosphate ester based hydraulic oil
- W = Fatty ester based hydraulic oil
- Water-glycol based hydraulic oil

Electric connection symbol

- B = DIN connector
- C = DIN large connector
- E = Amplifier mounted type

Solenoid ratings

E = 14.2Ω × 0.8A

Sub-plate

Valve type	Sub-plate type	Connection diameter	Mass
RDPV5	P-RDPV5R14-0	Rc 1/4	2kg
	P-RDPV5G14-0	G 1/4	

When you use a sub-plate, please place an order for the above sub-plate type.

Accessories

Mounting bolt

Type	Hexagon socket head cap thread	Quantity	Tightening torque N · m (kgf · cm)
RDPV5	M5 × 55L	4 pcs.	6.9 ± 1.0 (70 ± 10.5)

Specifications

Nominal dimension		5	
Maximum working pressure MPa (kgf/cm ²)	Port P	34.3 (350)	
	Port T	1.0 (10)	
Maximum flow rate L/min		3	
Reproducibility %		2 or less	
Hysteresis %		3 or less	
Electrical specifications	Solenoid rated current mA	See the Current - Pressure Characteristics (the following figure).	
	Coil resistance Ω	14.2 at 20°C	
	Dither (Recommendable value)	200HzPWM/200Hz, 200mAP-P	
	In case the amplifier is installed separately	Standard amplifier type	KC-B10/C-B10-A ¹⁰⁰ / ₂₀₀
	In case of amplifier mounted type	Power source	DC24V
Command voltage		0 to 5V	
Mass kg	RDPV5P-10/*-E ^B / _C	2.7	
	RDPV5P-10/*-EE	3.2	

Current - Pressure characteristics (viscosity 25 mm²/s (cSt))

●RDPV5

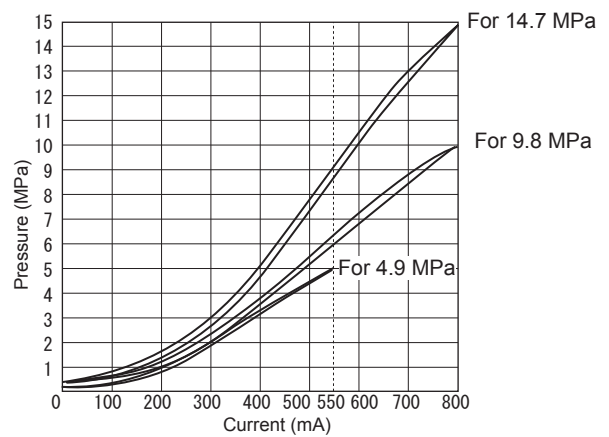
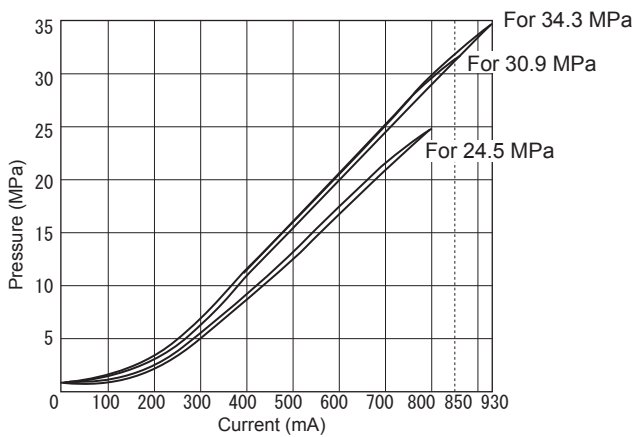

Pressure override characteristics (viscosity 25 mm²/s (cSt))

●RDPV5

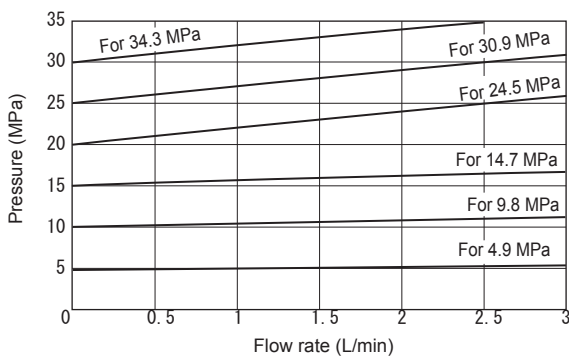

Minimum adjustment pressure characteristics (viscosity 25 mm²/s (cSt))

●RDPV5

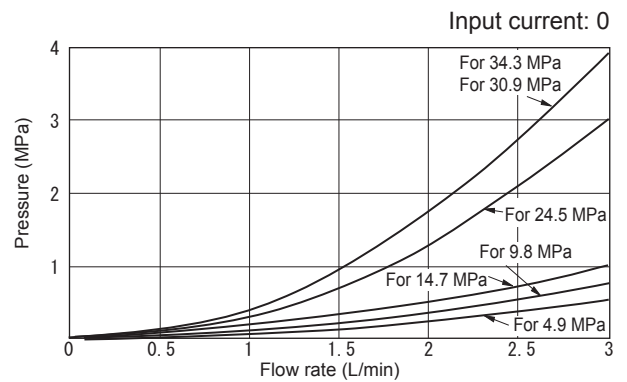

Dimension drawing

●RDPV5P-10/*E^B_C

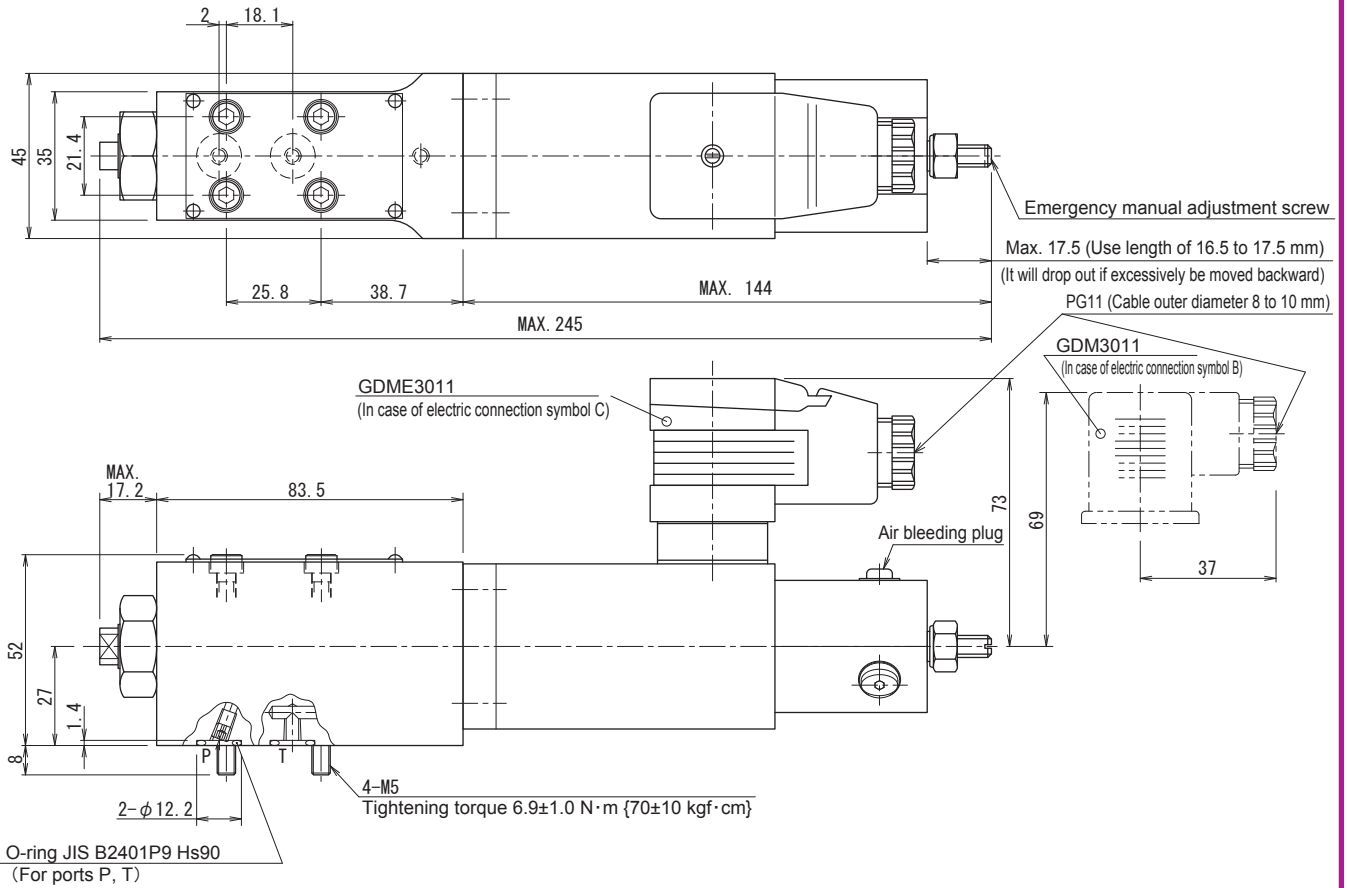

●RDPV5P-10/*EE

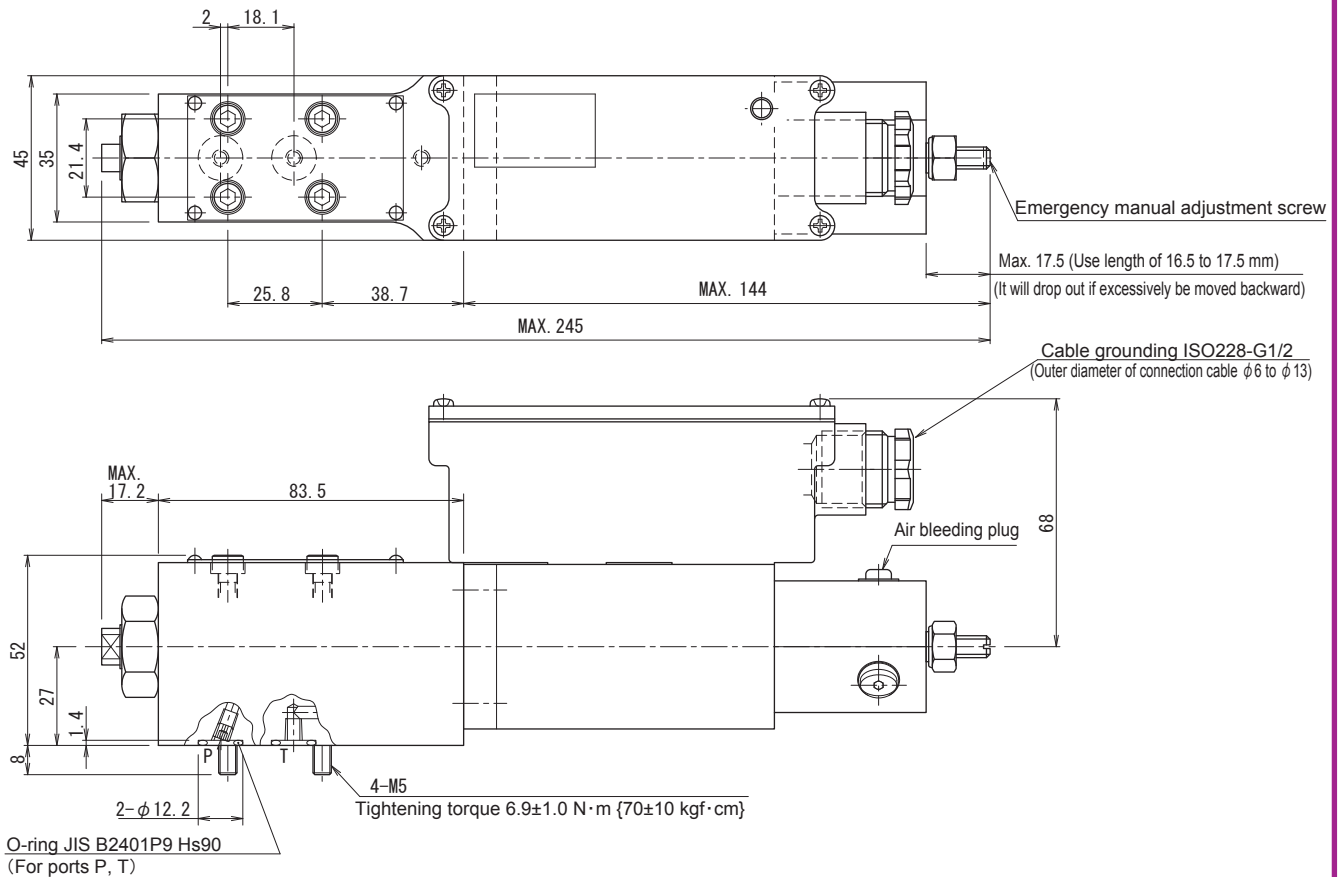

Solenoid proportional balanced piston type relief valve **RBP**

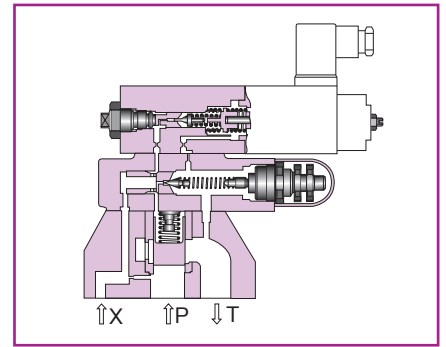
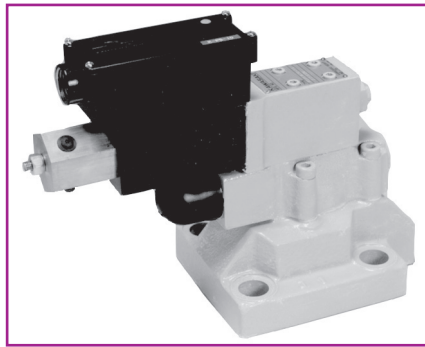
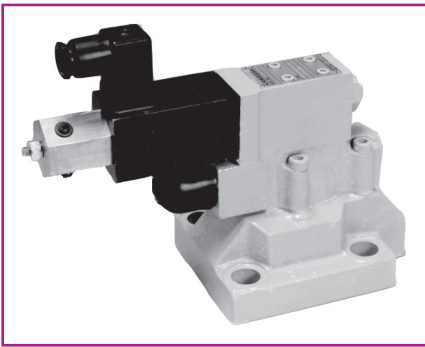

Overview

The solenoid proportional balanced piston type relief valve consists of the solenoid proportional pilot relief valve and balanced piston type relief valve, and allows hydraulic pressure to be remotely controlled at a given rate in proportion to the input current. In addition, amplifier mounted types are controlled by voltage input. Various serieses are lined up including high pressure, high flow rate, therefore, the best suited equipment can be selected for your usage.

Features

1. The maximum pressure limiting device provides safety measures against abnormal pressure.
2. Special damping mechanism in the solenoid proportional pilot relief valve realises superior stability even at high pressure 34.3 MPa (350 kgf/cm²).
3. During the initial adjustment or malfunction in the electrical system, manual operation can be done with the manual pressure adjustment thread on the pilot relief valve.
4. Easy handling amplifier mounted type is also lined up.

Type indication

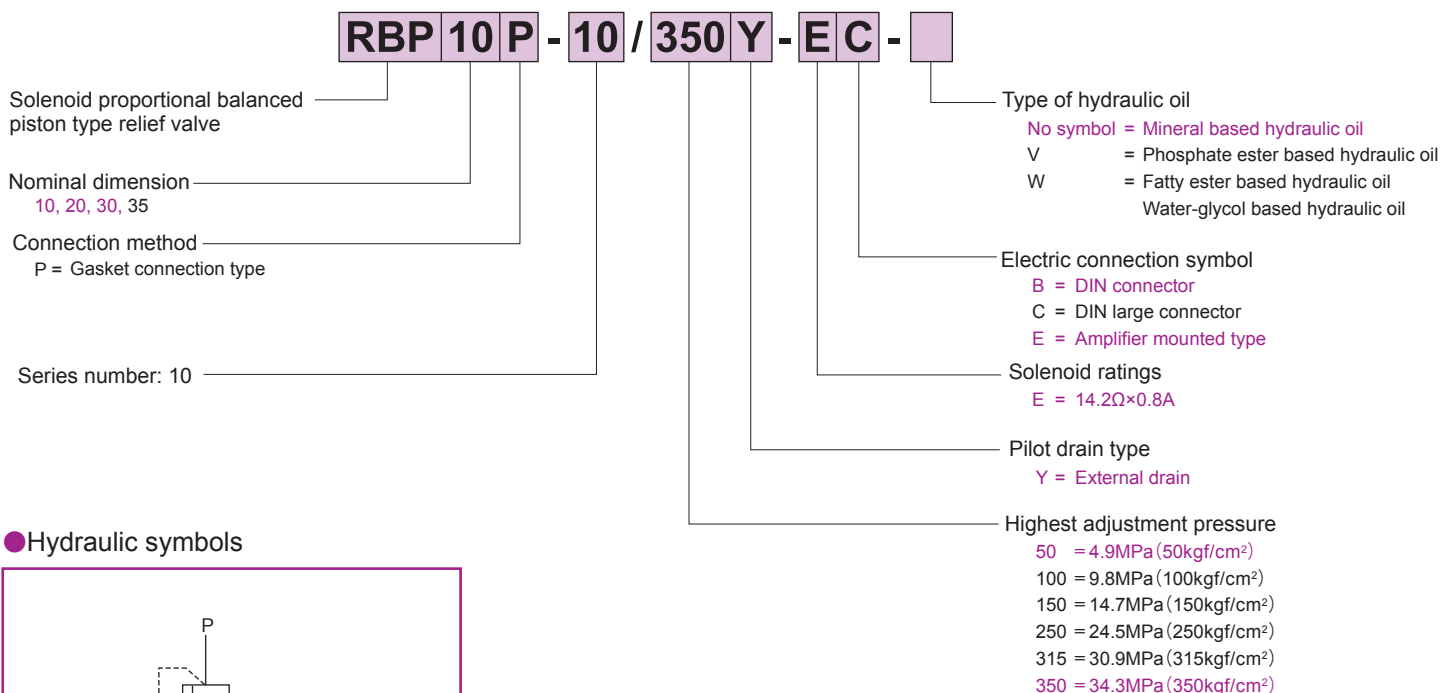

Hydraulic symbols

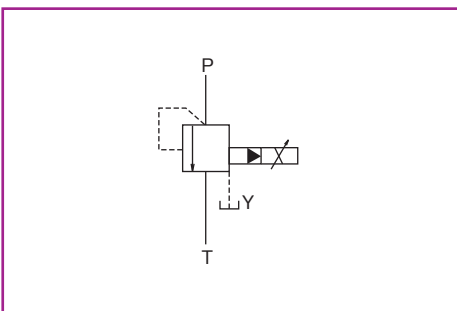

Specifications

Nominal dimension		10	20	30	35
Maximum working pressure MPa (kgf/cm ²)	Ports P, T, and X	34.3 (350)			
	Port Y	1.0 (10)			
Maximum flow rate L/min		150	300	500	700
Reproducibility %		2 or less			
Hysteresis %		5 or less			
Electrical specifications	Solenoid rated current mA	See the Current - Pressure Characteristics (the following figure).			
	Coil resistance Ω	14.2 at 20°C			
	Dither (Recommendable value)	200HzPWM/200Hz, 200mAP-P			
	In case the amplifier is installed separately	Standard amplifier type	KC-B10/C-B10-A ¹⁰⁰ / ₂₀₀		
	In case of amplifier mounted type	Power source	DC24V		
Command voltage		0 to 5V			
Mass kg	RBP*P-10/*-E _C ^B	5.3	6.2	7.1	20.5
	RBP*P-10/*-EE	5.8	6.7	7.6	21

Sub-plate

Valve type	Sub-plate type	Connection diameter	Mass
RBP10	P-RB10R14-0	Rc 1/4	2.1kg
	P-RB10G14-0	G 1/4	
	P-RB10R38-0	Rc 3/8	
	P-RB10G38-0	G 3/8	
	P-RB10R12-0	Rc 1/2	
	P-RB10G12-0	G 1/2	
RBP20	P-RB20R34-0	Rc 3/4	4.4kg
	P-RB20G34-0	G 3/4	
	P-RB20R1-0	Rc1	
	P-RB20G1-0	G1	
RBP30	P-RB30R54-0	Rc1 1/4	6.9kg
	P-RB30G54-0	G1 1/4	
	P-RB30R32-0	Rc1 1/2	
	P-RB30G32-0	G1 1/2	

When you use a sub-plate, please place an order for the above sub-plate type.
For the dimension drawing, refer to page 5 and 6 of the appendix.

Accessories

● Mounting bolt

Type	Hexagon socket head cap thread	Quantity	Tightening torque N · m (kgf · cm)
RBP10	M12×45L	4 pcs.	98.0 ± 14.7 (1000 ± 150)
RBP20	M16×50L	4 pcs.	235.2 ± 35.2 (2400 ± 360)
RBP30	M18×50L	4 pcs.	333.2 ± 50.0 (3400 ± 510)
RBP35	M16×70L	6 pcs.	235.2 ± 35.2 (2400 ± 360)

Current - Pressure characteristics (viscosity 25 mm²/s (cSt))

● RBP*

Flow rate: Maximum flow rate×1/2 Dither: 200 HzPWM

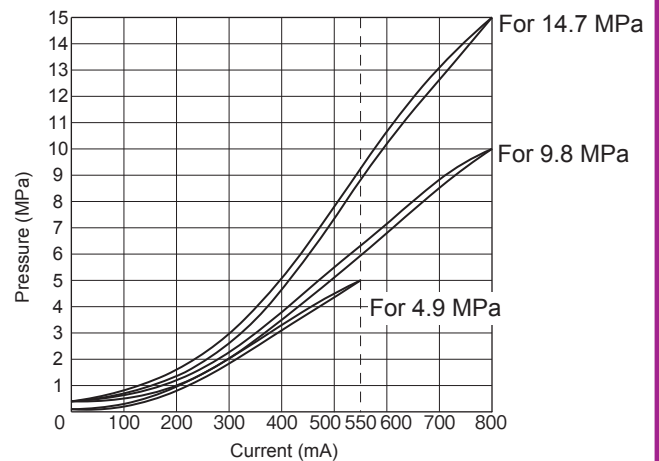
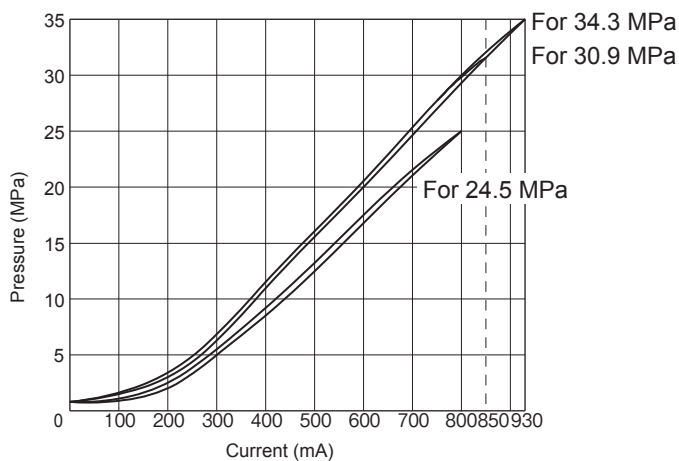

Pressure override characteristics (viscosity 25 mm²/s (cSt))

●RBP10

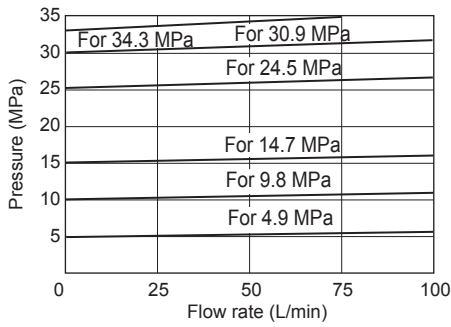

●RBP20

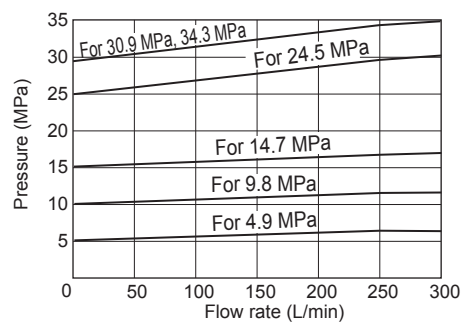

●RBP30

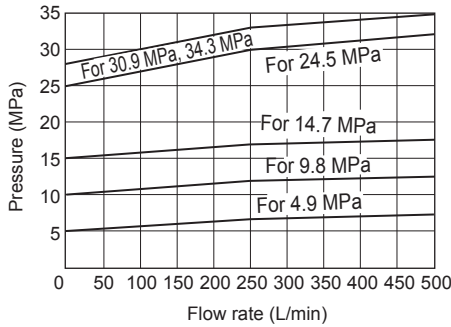

●RBP35

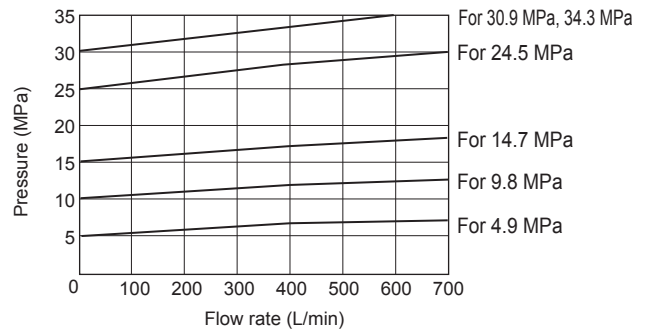

Minimum adjustment pressure characteristics (viscosity 25 mm²/s (cSt)) Input current: 0

●RBP10

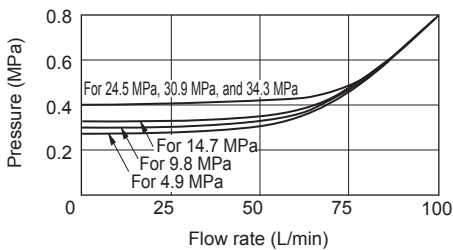

●RBP20

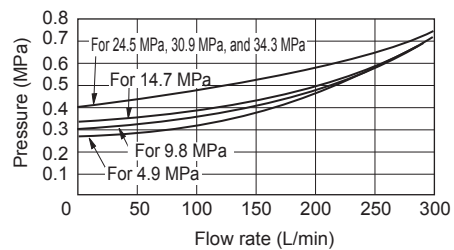

●RBP30

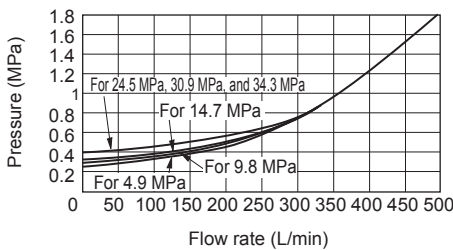

●RBP35

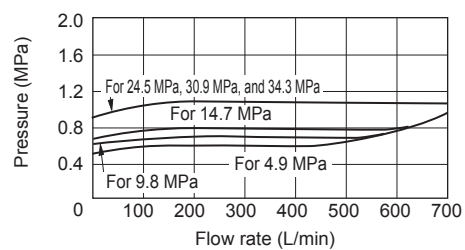

Dimension drawing

● RBP10, 20, 30P-10/*-E^B_C

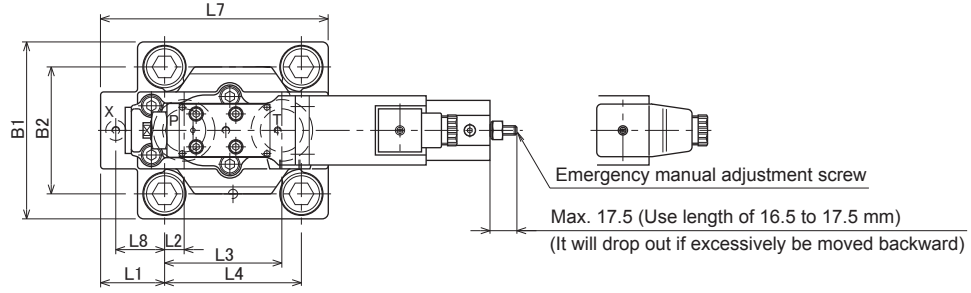

In case of electric connection symbol B (DIN connector GDM3011)

In case of electric connection symbol C (DIN large connector GDME3011)

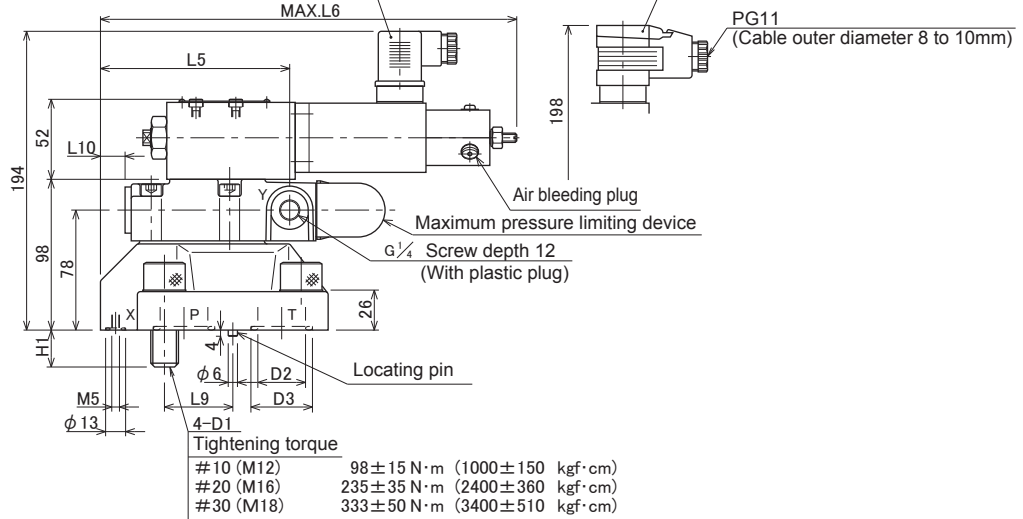

● RBP¹⁰/₂₀/₃₀P-10/*-EE

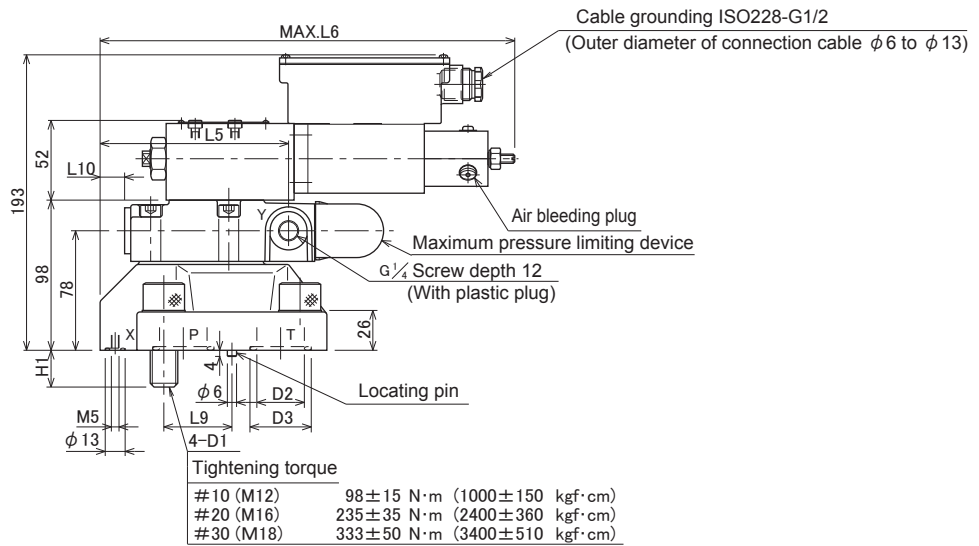
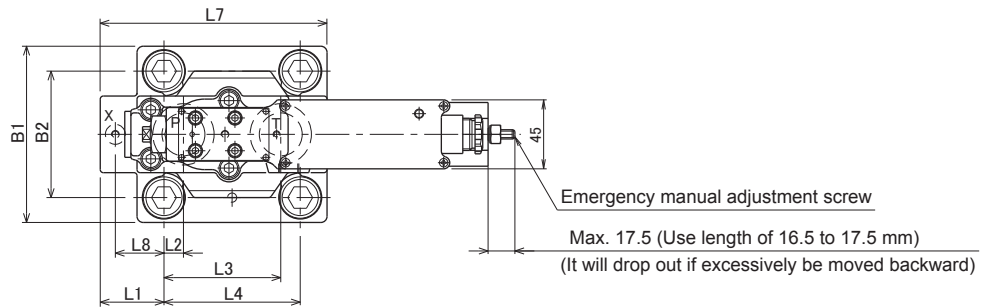

Nominal dimension	B1	B2	D1	D2	D3	L1	L2	L3	L4	L5	L6	L7	L8	L9	L10	H1	O-ring JIS B2401	
																	P and T ports	T port
10	78	54	M12	12	20	23.5	22.1	47.6	54	99.5	251	90	0	22.1	*-7.5	19	P16,Hs 90	P10,Hs 90
20	100	69.8	M16	25	35	34	11.1	55.6	66.7	112.7	265	117	23.8	33.3	5.7	24	G30,Hs 90	P10,Hs 90
30	115	82.5	M18	31	40	41.5	12.7	76.2	88.9	122.9	275	148	31.7	44.4	15.9	24	G35,Hs 90	P10,Hs 90

*The symbol (-) indicates that the dimension shown is measured in the outside position.

● RBP35P-10/*-E^B_C

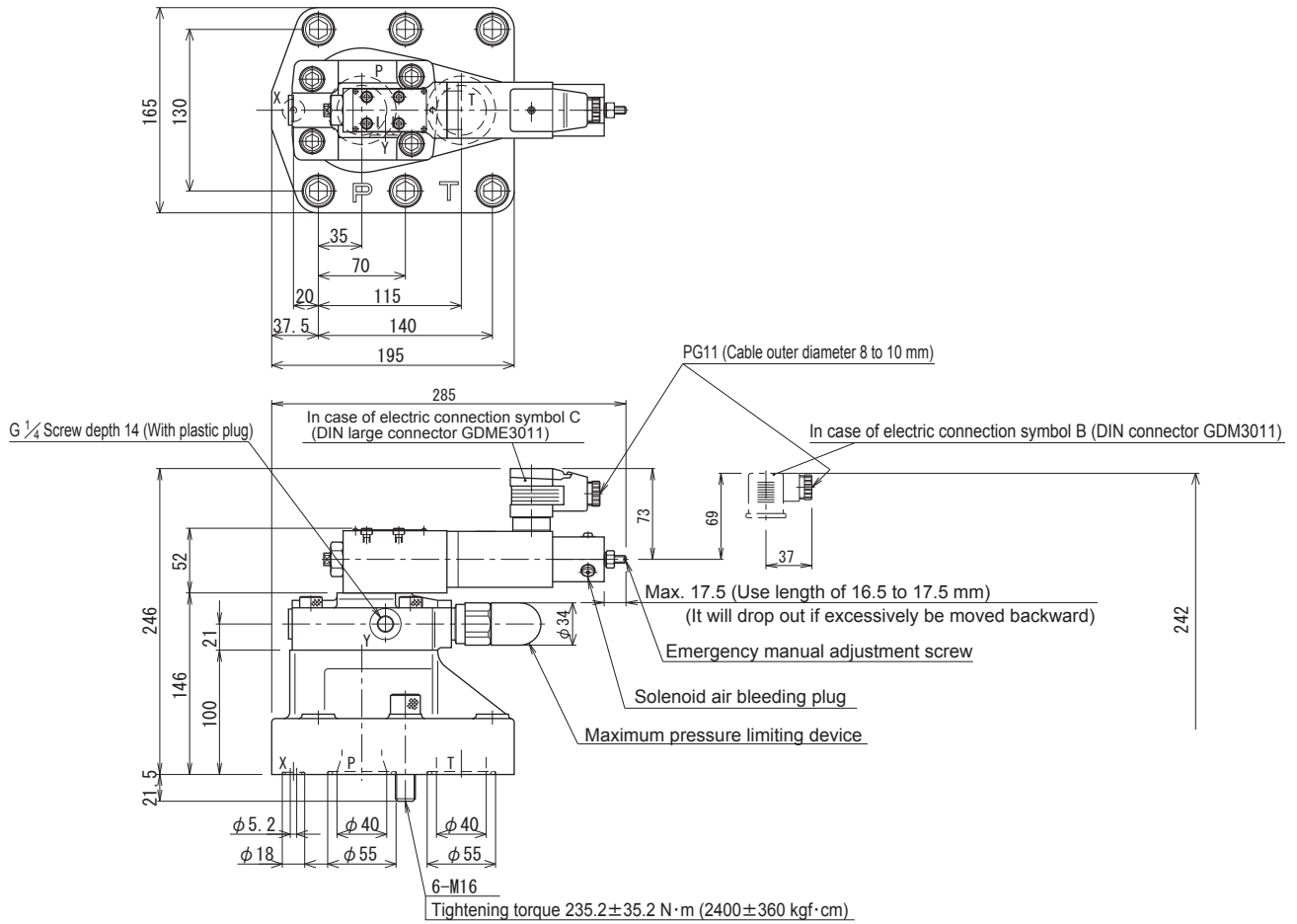

● RBP35P-10/*-EE

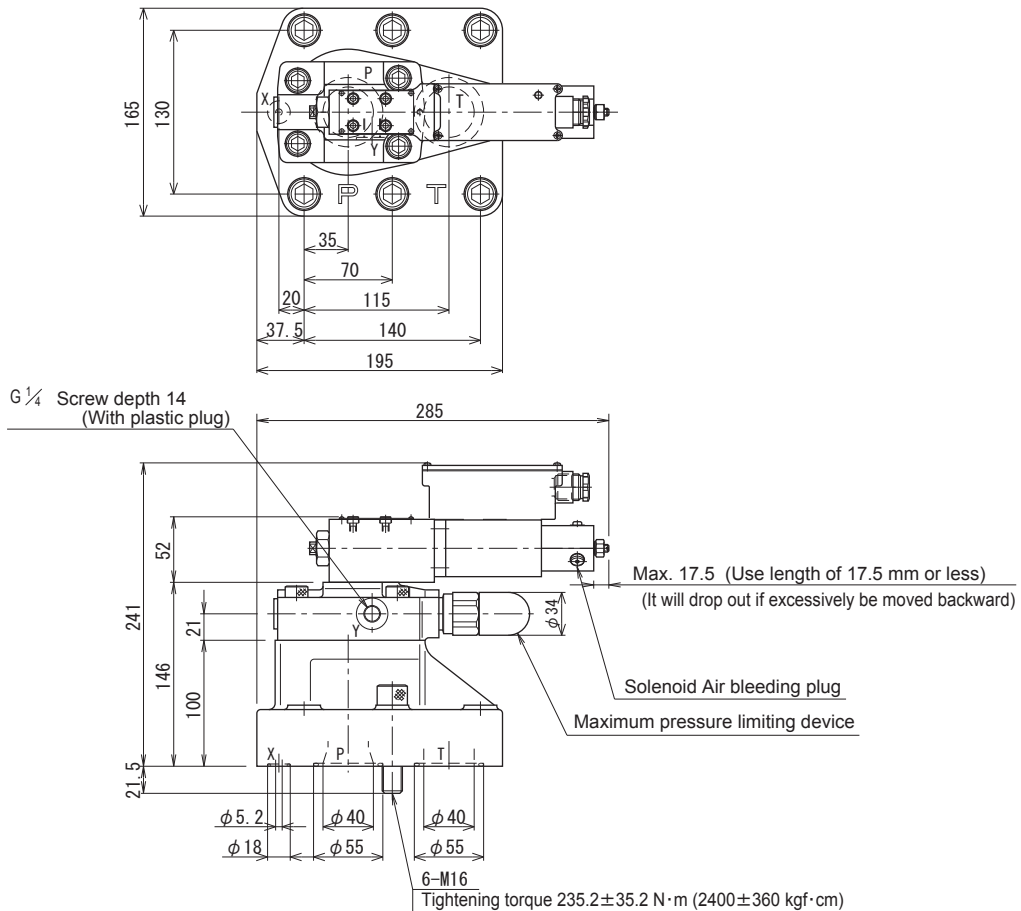

Solenoid proportional pilot pressure reducing valve – Direct operated type **PRDP6**

Solenoid proportional pilot pressure reducing valve – Direct operated type

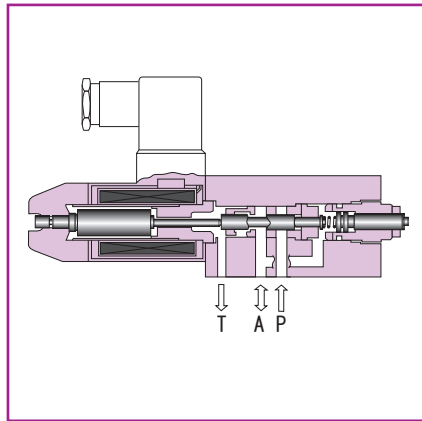
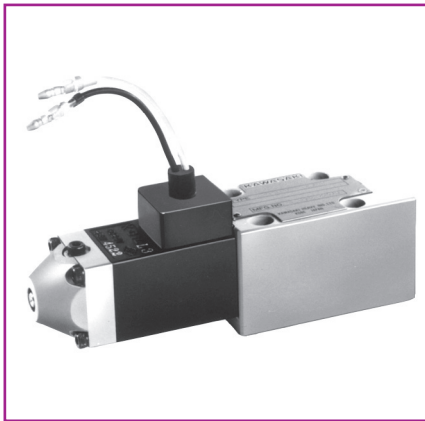

● Hydraulic symbols

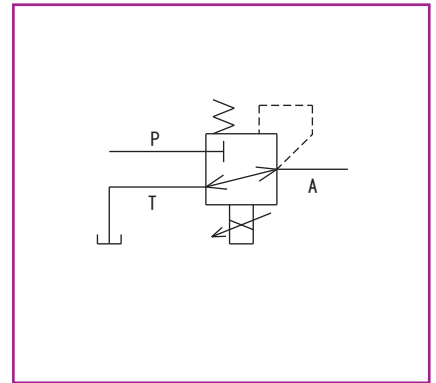

■ Overview

It consists of the DC proportional solenoid and spool type direct operated pressure reducing valve, and the position of the directional flow regulating valve and allows tilting angle of the variable capacity pump to be remotely controlled at a rate in proportion to the input current.

■ Features

1. Exclusively for single solenoid type, small size, and inexpensive.
2. Special damping mechanism with a spring realises superior stability.
3. During the initial adjustment or malfunction in the electrical system, manual operation can be done with the push rod.

■ Type indication

PRDP 6 P - 10 / 30 - C B -

Solenoid proportional type
Direct operated type pilot pressure reducing valve

Nominal dimension
6

Connection method
P = Gasket connection type
R = Rc thread connection type
G = G thread connection type

Series number: 10

Maximum adjustment pressure
30 = 2.9MPa (30kgf/cm²)
50 = 4.9MPa (50kgf/cm²)

Type of hydraulic oil

No symbol = Mineral based hydraulic oil
V = Phosphate ester based hydraulic oil
W = Fatty ester based hydraulic oil
Water-glycol based hydraulic oil

Electric connection symbol

B = DIN connector
C = DIN large connector
L = Lead wire (with sure plug)

Solenoid ratings

C = 24Ω × 0.75A
D = 6Ω × 1.5A

■ Specifications

Nominal dimension		PRDP6*-10/30	PRDP6*-10/50
Maximum working pressure MPa (kgf/cm ²)	Port P, A	13.7 (140)	
	Port T	1.0 (10)	
Secondary control pressure MPa (kgf/cm ²)		0 to 2.9 (0 to 30)	0 to 4.9 (0 to 50)
Reproducibility %		2 or less	
Hysteresis %		5 or less	
Electrical specifications	Rated current mA	700/1, 400	
	Coil resistance Ω	24/6 at 20°C	
	Dither (Recommendable value)	60Hz, 150/300mAP-P	
	Standard amplifier type	C-B10-A ¹⁰⁰ / ₂₀₀ /C-B15-D24	
Mass kg		2.5	

■ Sub-plate

Valve type	Sub-plate type	Connection diameter	Mass
PRDP6	P-DE6R14-0	Rc 1/4	1.0kg
	P-DE6G14-0	G 1/4	
	P-DE6R38-0	Rc 3/8	1.3kg
	P-DE6G38-0	G 3/8	

When you use a sub-plate, please place an order for the above sub-plate type.

For the dimension drawing, refer to page 11 of the appendix.

■ Accessories

● Mounting bolt

Type	Hexagon socket head cap thread	Quantity	Tightening torque N · m (kgf · cm)
PRDP6	M5 × 50L	4 pcs.	6.9 ± 1.0 (70 ± 10.5)

Current - Pressure characteristics (viscosity 25 mm²/s (cSt))

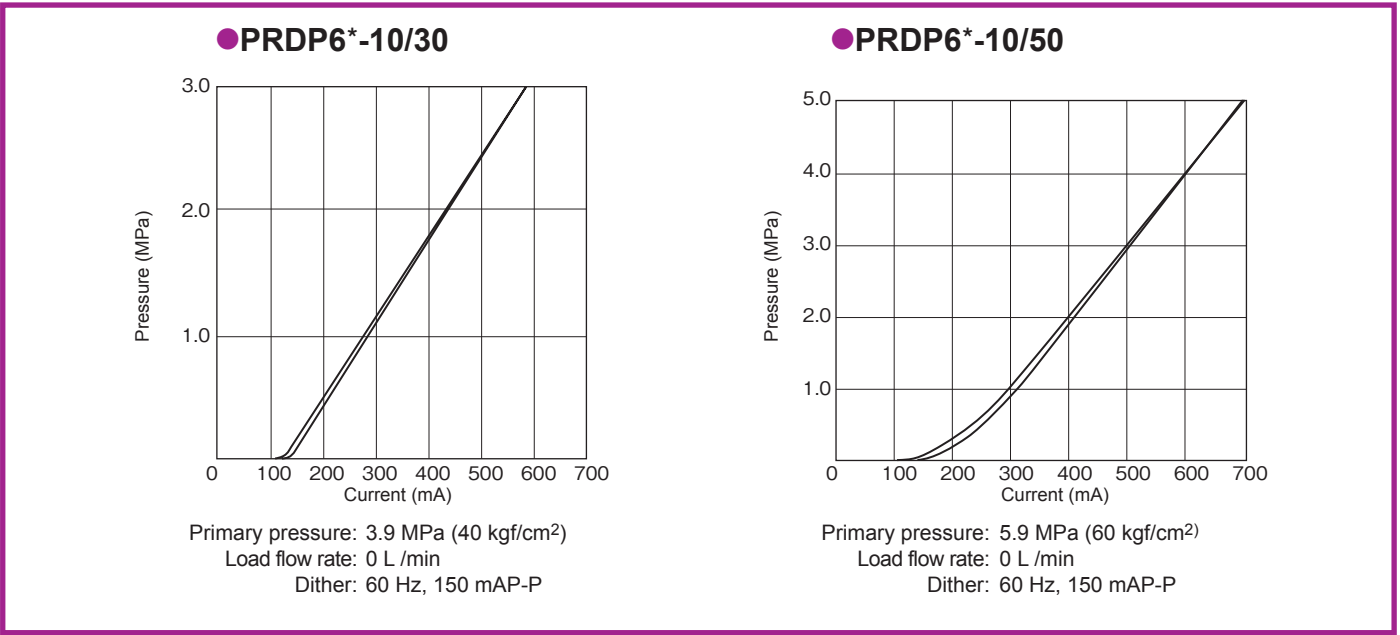

Load pressure – Flow rate characteristics (viscosity 25 mm²/s (cSt))

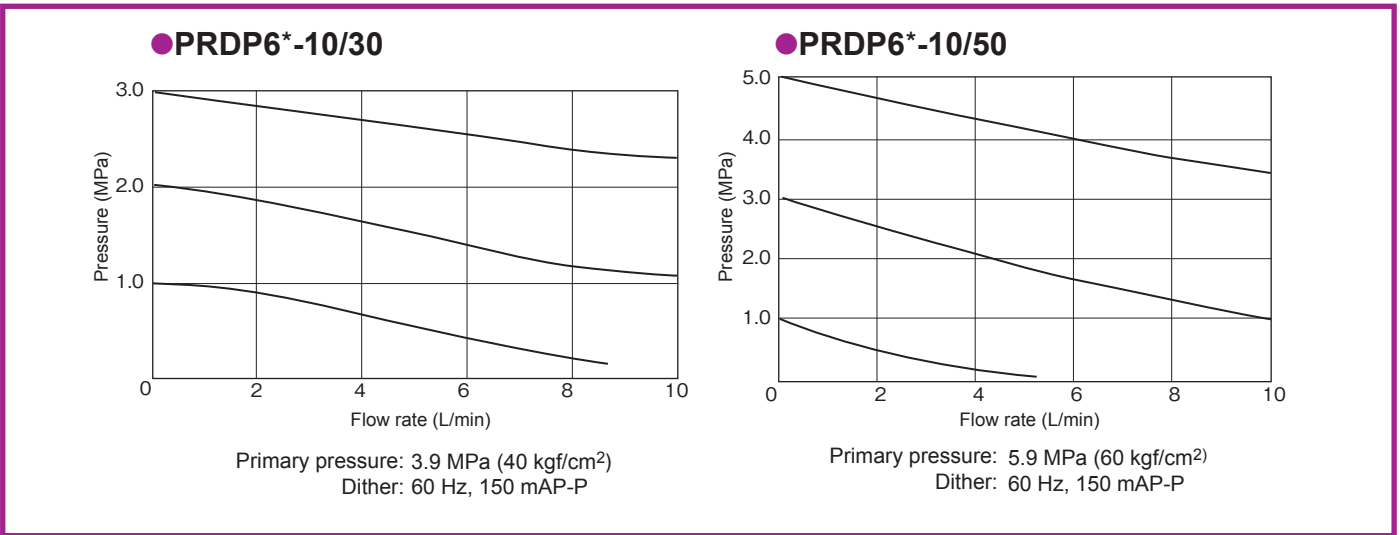

Step response characteristics (viscosity 25 mm²/s (cSt))

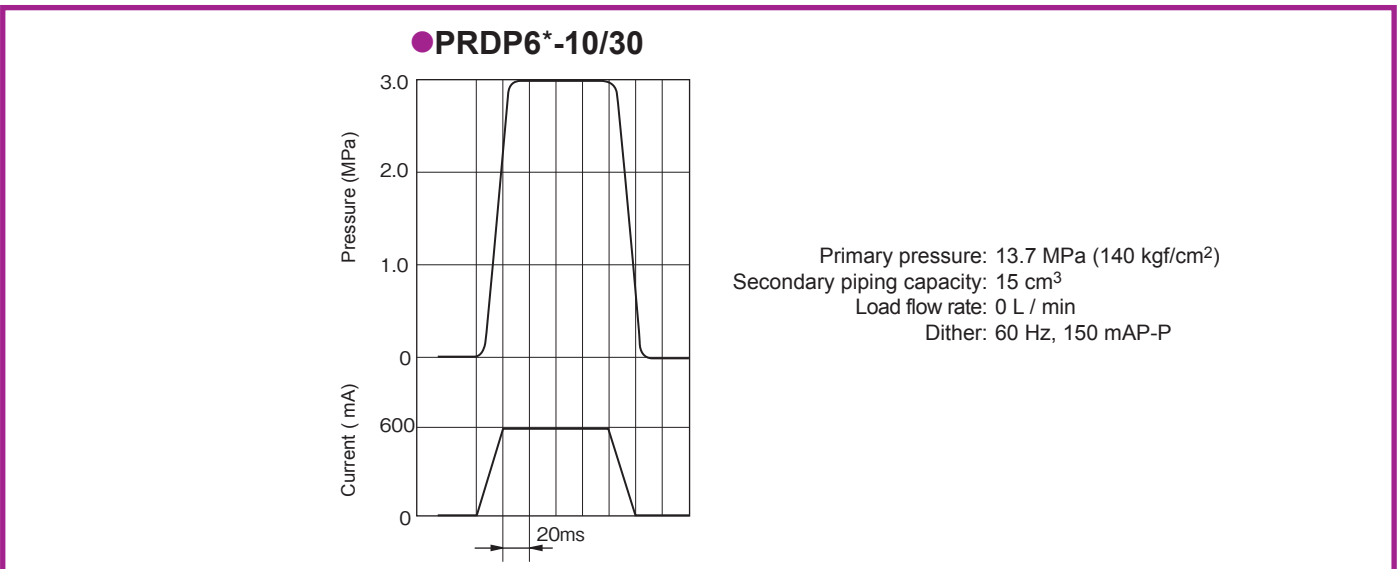

Dimension drawing

● PRDP6P

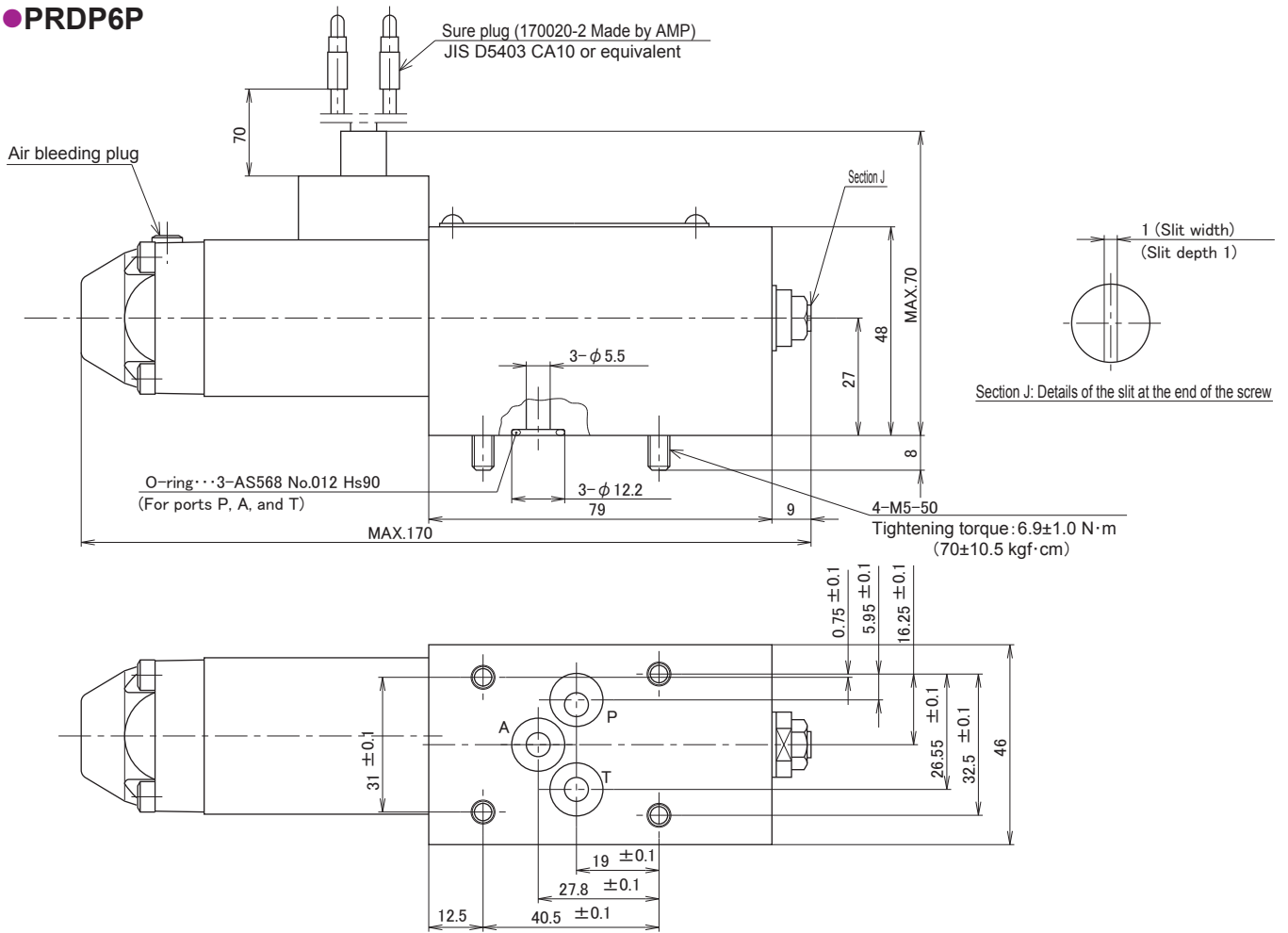

● PRDP6G

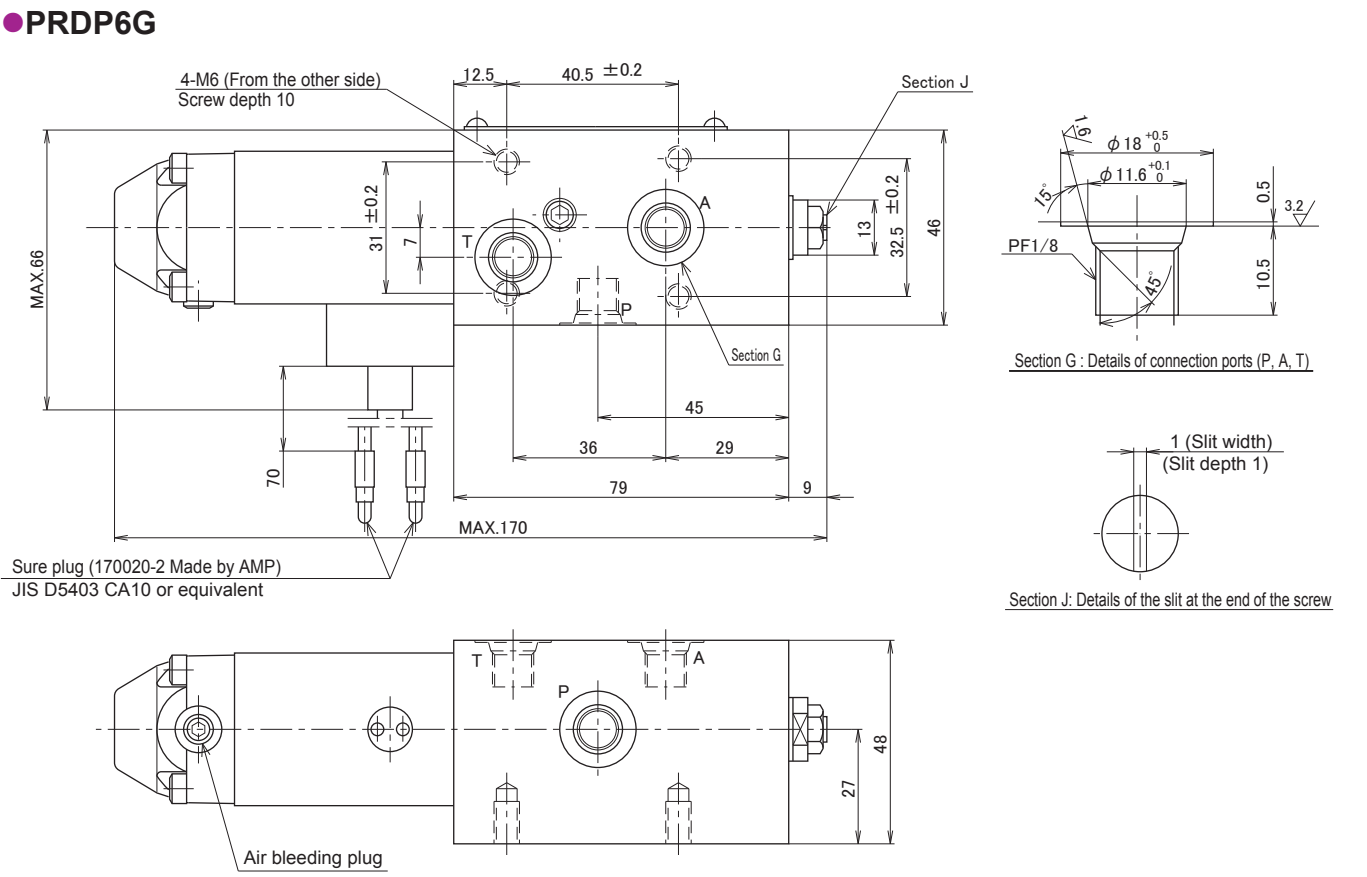

Solenoid proportional pilot pressure reducing valve - Direct operated type

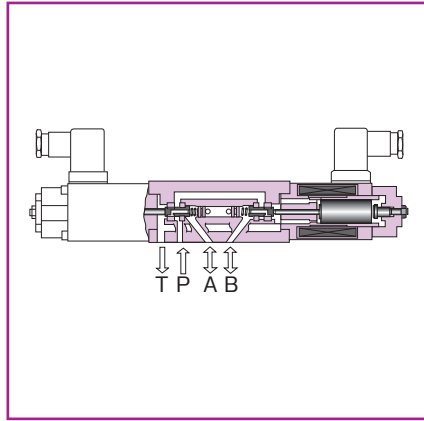
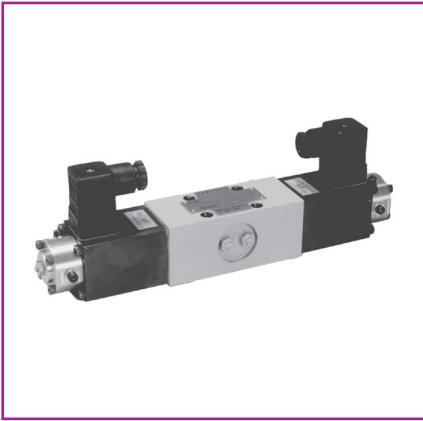

● Hydraulic symbols

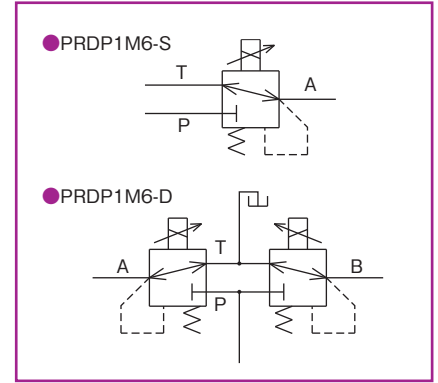

■ Overview

It consists of the DC proportional solenoid and spool type direct operated pressure reducing valve, and the position of the directional flow regulating valve and allows tilting angle of the variable capacity pump to be remotely controlled at a rate in proportion to the input current.

■ Features

1. Special damping mechanism with a spring realises superior stability even at high pressure of 30.9 MPa (315 kgf/cm²) being applied to the primary side.
2. During the initial adjustment or malfunction in the electrical system, manual operation can be done with the manual pressure adjustment thread.

■ Type indication

PRDP1M 6 P - 10 - D / 20 - AC -

Solenoid proportional type
Direct operated type pilot pressure reducing valve
Nominal dimension
6
Connection method
P = Gasket connection type
Series number: 10
Type of the solenoid
S = Single solenoid type
D = Double solenoid type

Maximum adjustment pressure
15 = 1.5MPa(15kgf/cm²)
20 = 2.0MPa(20kgf/cm²)

Type of hydraulic oil
No symbol = Mineral based hydraulic oil
V = Phosphate ester based hydraulic oil
W = Fatty ester based hydraulic oil
Water-glycol based hydraulic oil
Electric connection symbol
B = DIN connector
C = DIN large connector
Solenoid ratings
A = 33Ω×0.75A
B = 7.2Ω×1.5 A

■ Specifications

Nominal dimension		PRDP1M6-D	PRDP1M6-S
Maximum working pressure MPa (kgf/cm ²)	Port P, A	30.9(315)	
	Port T	1.0(10)	
Working pressure range MPa (kgf/cm ²)		Up to 30.9(315)	
Reproducibility %		2 or less	
Hysteresis %		3 or less	
Electrical specifications	Rated current mA	750/1,500	
	Coil resistance Ω	33//7.2	
	Dither (Recommendable value)	60Hz, 200/350mAP-P	
	Standard amplifier type	CW-B10-A ^① /CW-B15-D24	C-B10-A ^② /C-B15-D24
Mass kg		4.3	3.2

■ Sub-plate

Valve type	Sub-plate type	Connection diameter	Mass
PRDP1M6	P-DE6R14-0	Rc ¹ / ₄	1.0kg
	P-DE6G14-0	G ¹ / ₄	
	P-DE6R38-0	Rc ³ / ₈	1.3kg
	P-DE6G38-0	G ³ / ₈	

When you use a sub-plate, please place an order for the above sub-plate type. For the dimension drawing, refer to page 11 of the appendix.

■ Accessories

● Mounting bolt

Type	Hexagon socket head cap thread	Quantity	Tightening torque N · m (kgf · cm)
PRDP1M6	M5×50L	4 pcs.	6.9±1.0(70±10.5)

Current - Pressure characteristics (viscosity 25 mm²/s (cSt))

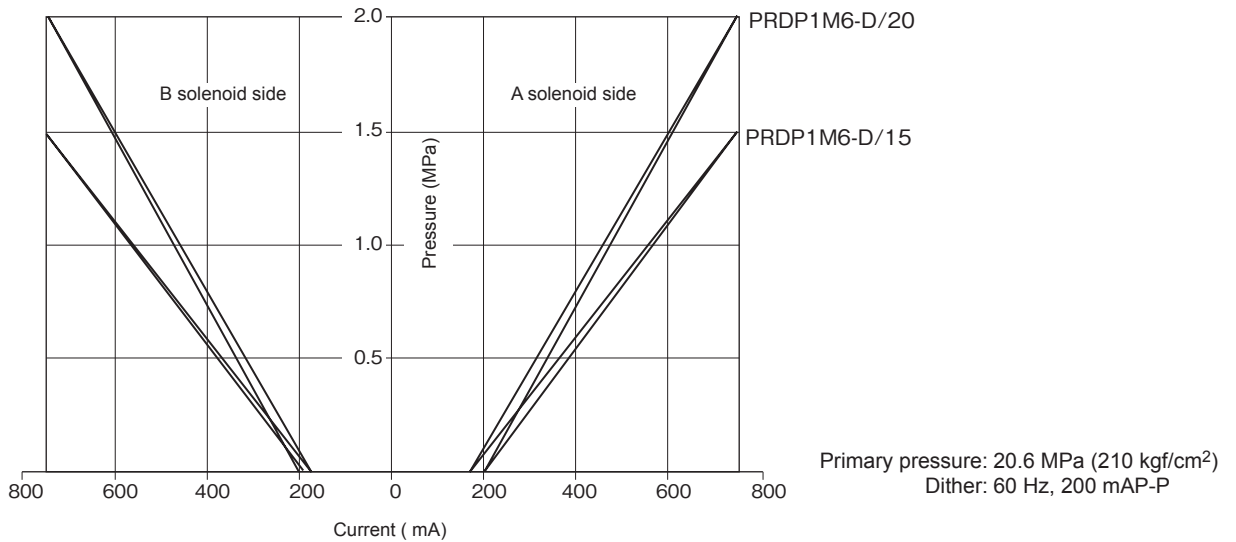

Load pressure – Flow rate characteristics (viscosity 25 mm²/s (cSt))

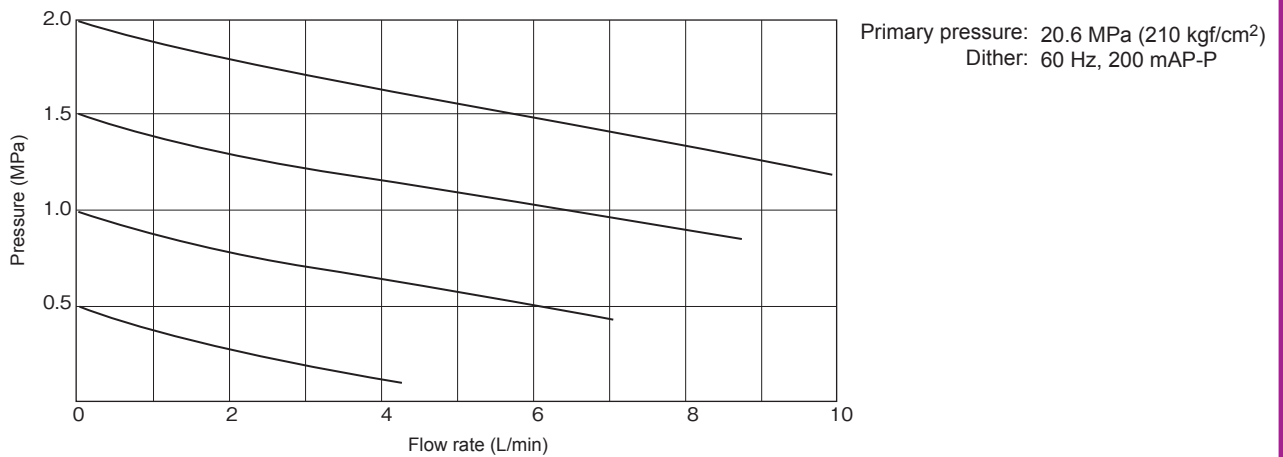

Step response characteristics (viscosity 25 mm²/s (cSt))

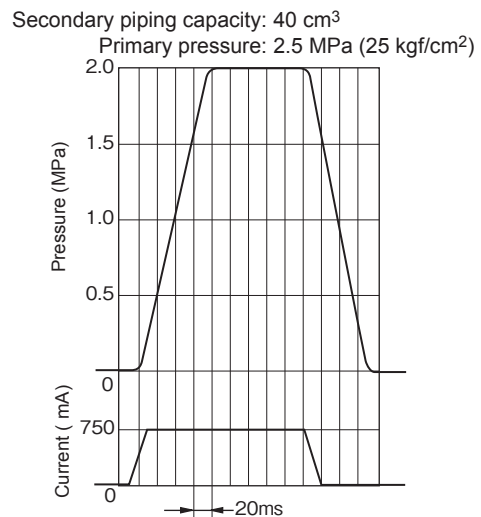
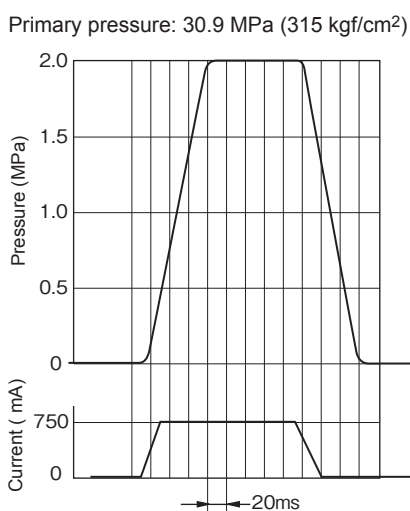

Dimension drawing

● PRDP1M6-D

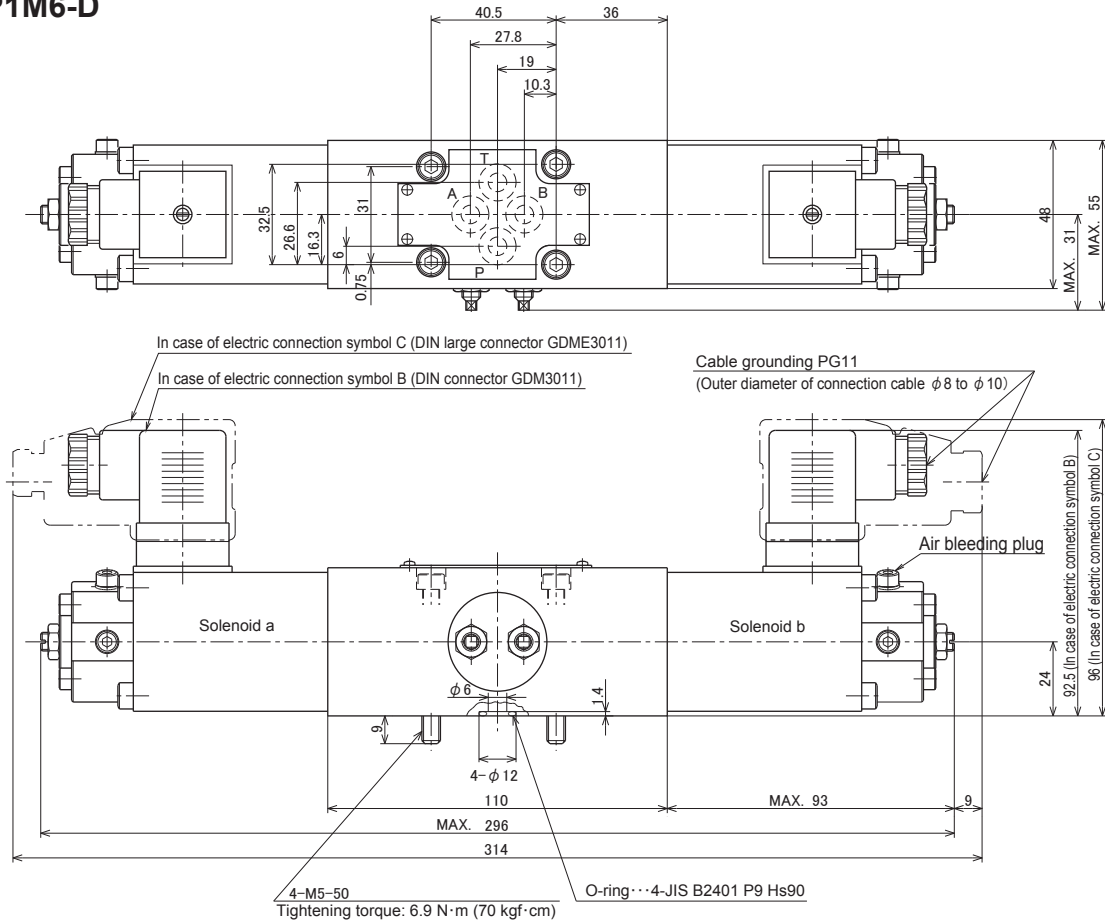

● PRDP1M6-S

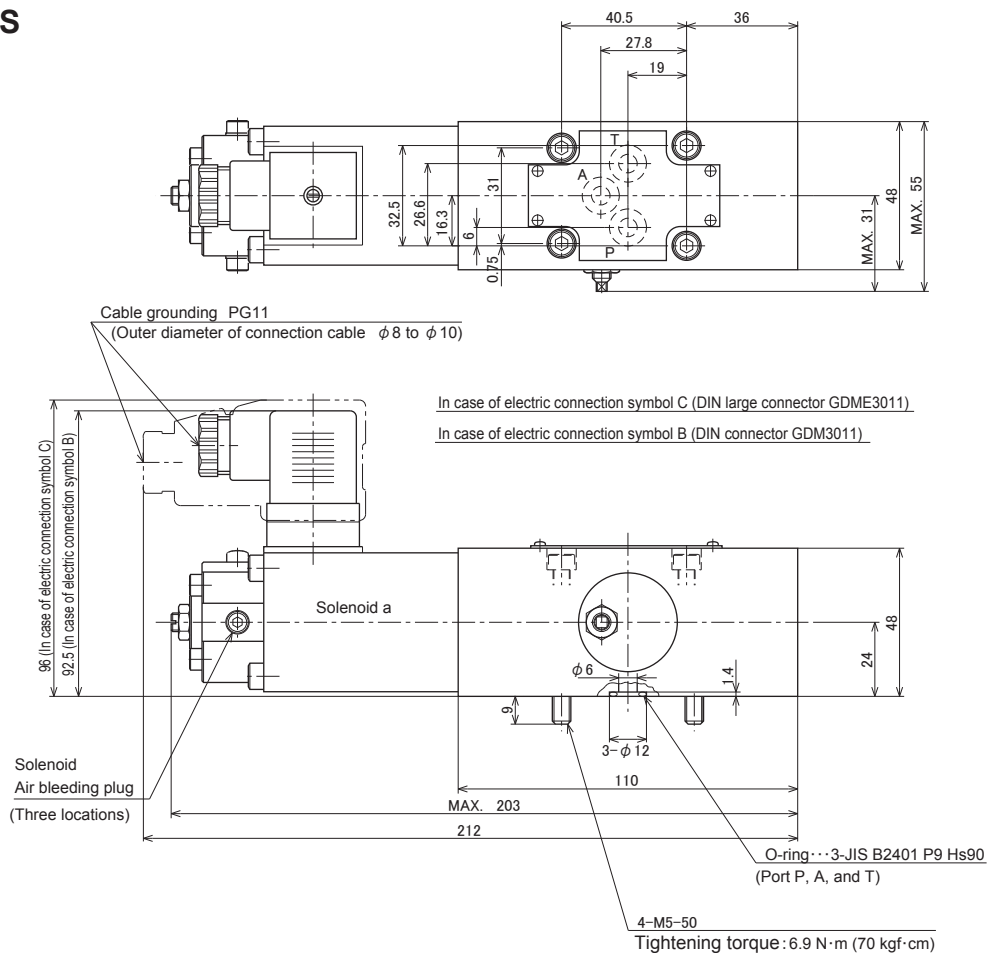

Solenoid proportional pilot pressure reducing valve – Direct operated type

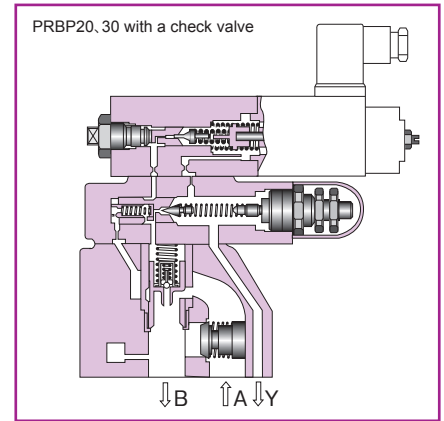
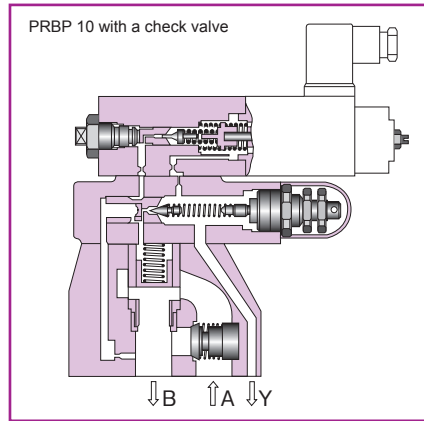
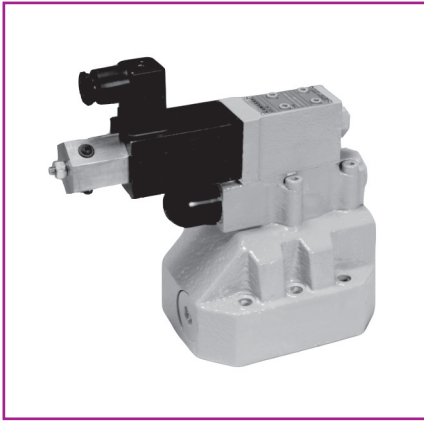

Pressure reducing valve of solenoid proportional balanced piston type

Overview

Pressure reducing valve of solenoid proportional balanced piston type consists of the solenoid proportional pilot relief valve and balanced piston type pressure reducing valve, and allows hydraulic system pressure to be remotely controlled at a given rate in proportion to the input current. In addition, amplifier mounted types are controlled by voltage input.

Features

1. The pilot pressure for the valve is supplied from the primary side, which allows the valve to use pilot flow even when the primary and secondary pressure difference or flow rate increases and provides stable performance. (Nominal dimension 20, 30)
2. The special damping mechanism is used in the solenoid proportional pilot relief valve, even when the primary and secondary pressure drastically changes, superior stability is obtained.
3. The maximum pressure limiting device provides safety measures against abnormal pressure.
4. During the initial adjustment or malfunction in the electrical system, manual operation can be done with the manual pressure adjustment thread on the pilot relief valve.
5. Easy handling amplifier mounted type is also lined up.

Type indication

PRBP 10 P - 10 / 350 C - EC -

Pressure reducing valve of solenoid proportional balanced piston type
Nominal dimension
10, 20, 30

Connection method
P = Gasket connection type

Series number: 10

Type of hydraulic oil

- No symbol = Mineral based hydraulic oil
- V = Phosphate ester based hydraulic oil
- W = Fatty ester based hydraulic oil
- Water-glycol based hydraulic oil

Electric connection symbol

- B = DIN connector
- C = DIN large connector
- E = Amplifier mounted type

Solenoid ratings

E = 14.2Q×0.8A

Types with/without check valve

- No symbol = Types without the valve
- C = Types with the valve

Highest adjustment pressure

- 50 = 4.9MPa (50kgf/cm²)
- 100 = 9.8MPa (100kgf/cm²)
- 150 = 14.7MPa (150kgf/cm²)
- 250 = 24.5MPa (250kgf/cm²)
- 315 = 30.9MPa (315kgf/cm²)
- 350 = 34.3MPa (350kgf/cm²)

Hydraulic symbols

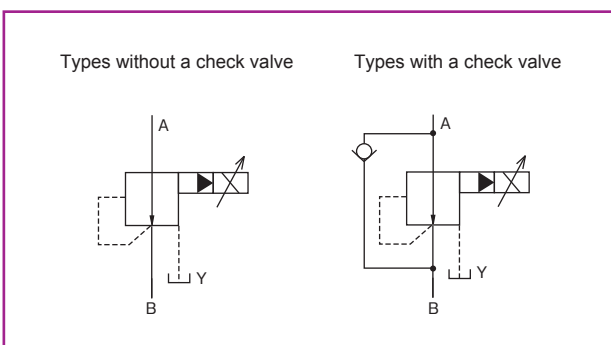

Specifications

Nominal dimension		10	20	30
Maximum working pressure MPa (kgf/cm ²)	Ports A, B	34.3 (350)		
	Port Y	1.0 (10) External drain, tank		
Maximum flow rate L/min		80	200	300
Reproducibility %		2 or less		
Hysteresis %		5 or less		
Electrical specifications	Solenoid rated current mA	See the Current - Pressure Characteristics (the following figure).		
	Coil resistance Ω	14.2 at 20°C		
	Dither (Recommendable value)	200HzPWM/200Hz, 200mAP-P		
	In case the amplifier is installed separately	Standard amplifier type	KC-B10/C-B10-A ¹⁰⁰ / ₂₀₀	
	In case of amplifier mounted type	Power source	DC24V	
Command voltage		0 to 5V		
Mass kg	PRBP*P-10/*-E ^B / _C	6.4	8.3	11.1
	PRBP*P-10/*-EE	6.9	8.8	11.6

Sub-plate

Valve type	Sub-plate type	Connection diameter	Mass
PRBP10	P-CHY10R14-0	Rc 1/4	2.1kg
	P-CHY10G14-0	G 1/4	
	P-CHY10R38-0	Rc 3/8	
	P-CHY10G38-0	G 3/8	
	P-CHY10R12-0	Rc 1/2	
	P-CHY10G12-0	G 1/2	
PRBP20	P-CHY20R34-0	Rc 3/4	4.4kg
	P-CHY20G34-0	G 3/4	
	P-CHY20R1-0	Rc 1	
	P-CHY20G1-0	G1	
PRBP30	P-CHY30R54-0	Rc 1 1/4	6.9kg
	P-CHY30G54-0	G 1 1/4	
	P-CHY30R32-0	Rc 1 1/2	
	P-CHY30G32-0	G 1 1/2	

When you use a sub-plate, please place an order for the above sub-plate type.
For the dimension drawing, refer to page 6, and 7 of the appendix.

Accessories

Mounting bolt

Type	Hexagon socket head cap thread	Quantity	Tightening torque N · m (kgf · cm)
PRBP10	M10×40L	4 pcs.	56.8±8.5(580±87)
PRBP20	M10×50L	4 pcs.	
PRBP30	M10×60L	6 pcs.	

Pressure reducing valve of solenoid proportional balanced piston type

Current - Pressure characteristics (viscosity 25 mm²/s (cSt))

PRBP*

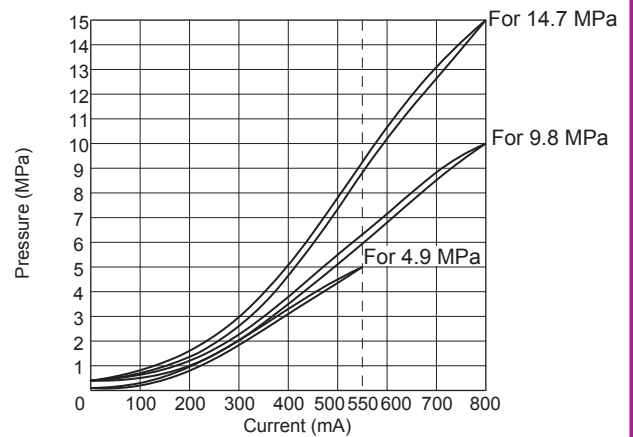
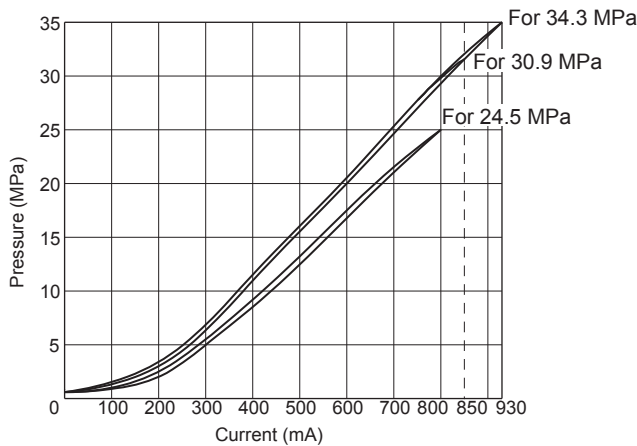

Pressure override characteristics (viscosity 25 mm²/s (cSt))

● PRBP10

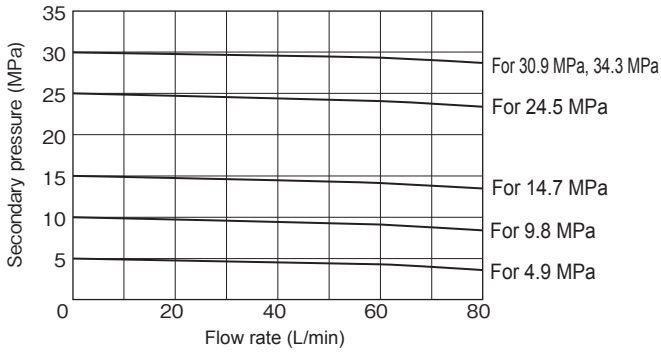

● PRBP20, 30

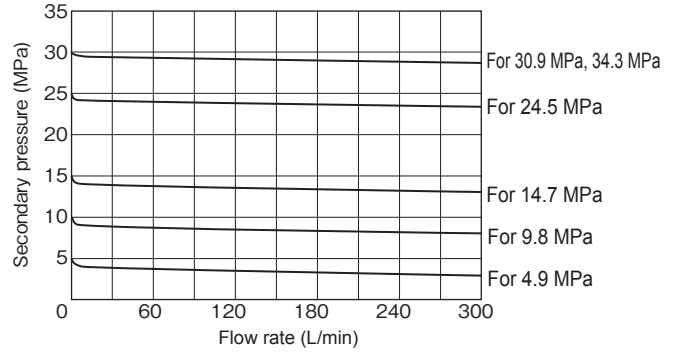

Secondary minimum adjustment pressure characteristics (viscosity 25 mm²/s (cSt)) Input current: 0

● PRBP10

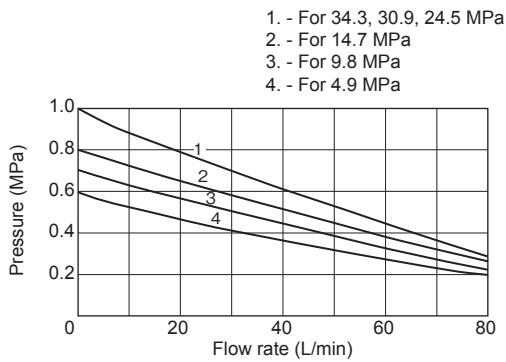

- 1. - For 34.3, 30.9, 24.5 MPa
- 2. - For 14.7 MPa
- 3. - For 9.8 MPa
- 4. - For 4.9 MPa

● PRBP20, 30

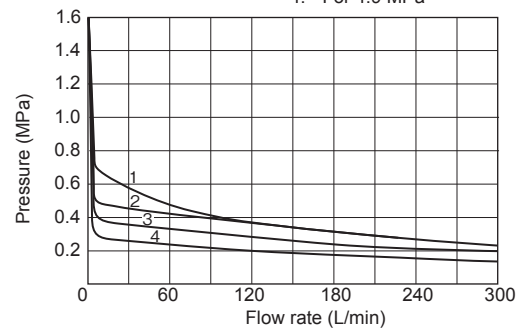

- 1. - For 34.3, 30.9, 24.5 MPa
- 2. - For 14.7 MPa
- 3. - For 9.8 MPa
- 4. - For 4.9 MPa

Dimension drawing

● PRBP 10 20 30 P-10/*-E B C

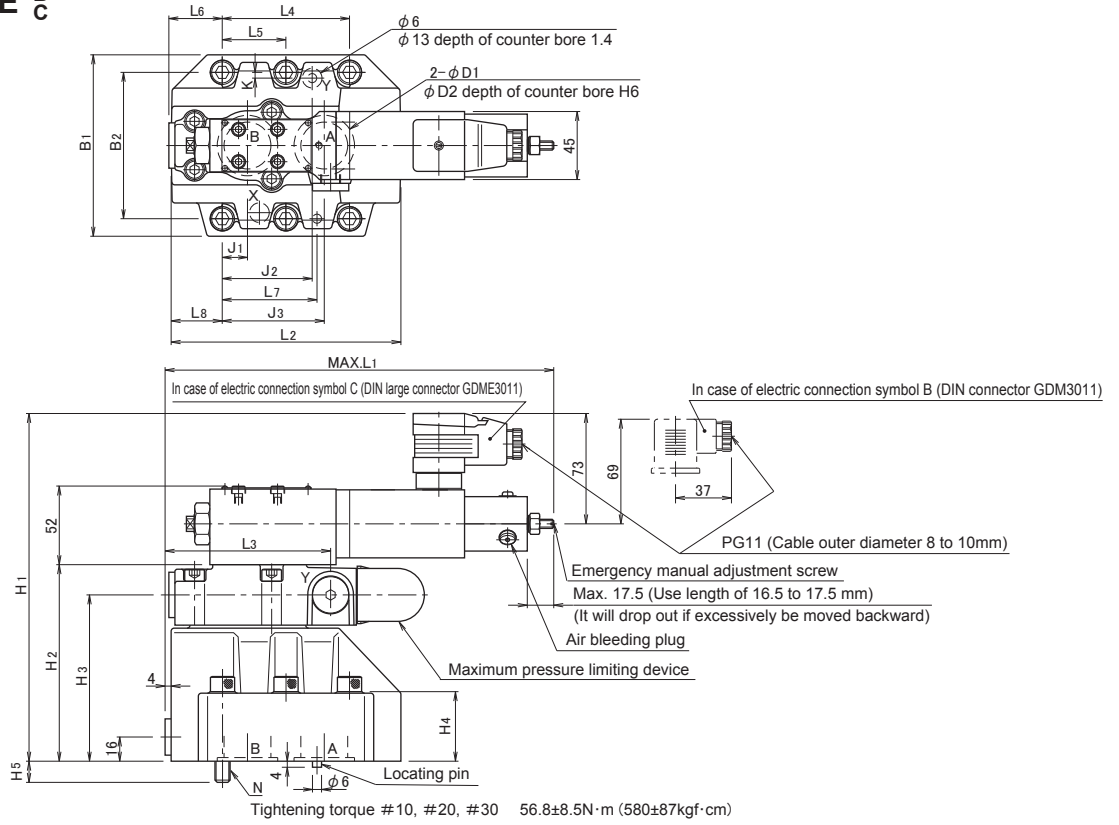

● PRBP 10 20 30 P-10/*-EE

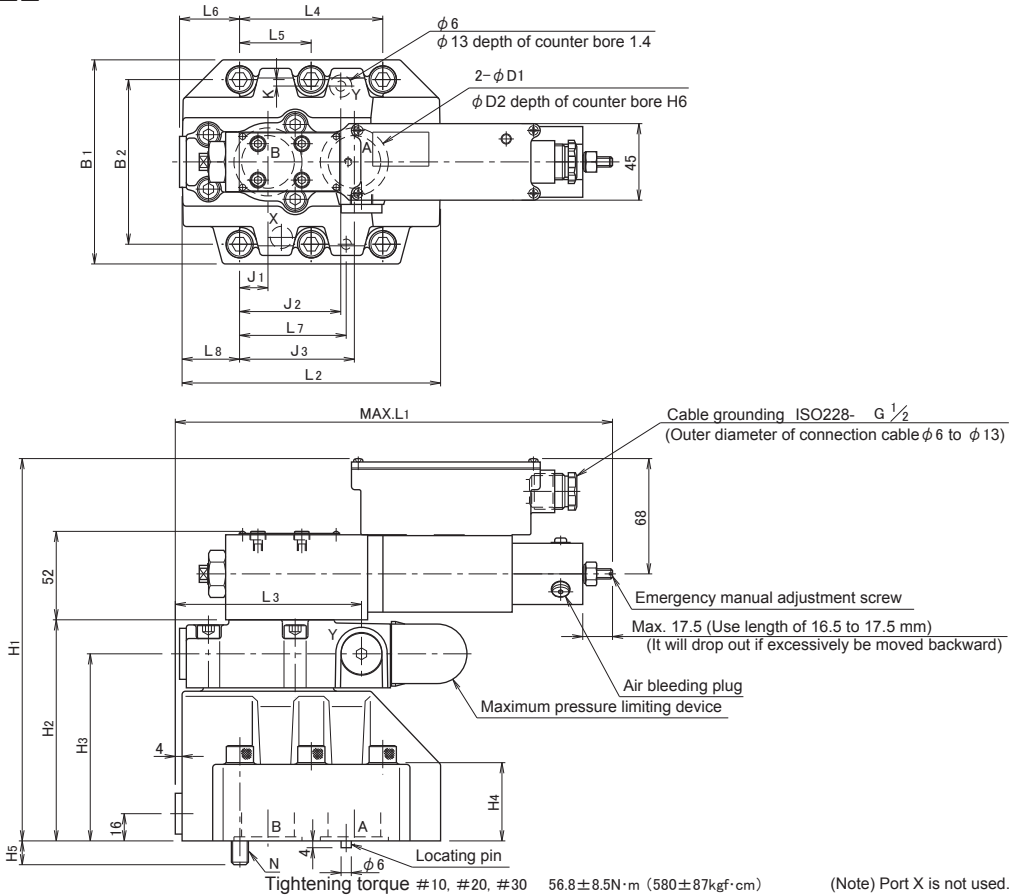

Nominal dimension	B1	B2	N	D1	D2	H1A	H1B	H2	H3	H4	H5	H6	L1	L2	L3	L4	L5	L6	L7	L8	O-ring JIS B2401	
																					A and B ports	X and Y ports
10	85	66.7	4-M10	15	22	212	207	112	92	28	12	1.8	256	104	108	42.9	—	38.5	31.8	35.5	P18, Hs90	
20	102	79.4		25	35	222	217	122	102	38	12		2.4	255	121	107		60.3	40.5	44.5	33.5	G30, Hs90
30	120	96.8		6-M10	31	40	230	225	130	110	46		14	2.4	257	153		109.8	84.2	42.1	35.5	62.7
Nominal dimension	J1	J2	J3	K																		
10	7.2	21.5	35.8	7.9																		
20	11.1	39.7	49.2	6.4																		
30	16.7	59.5	67.5	3.8																		

Pressure reducing valve of solenoid proportional balanced piston type

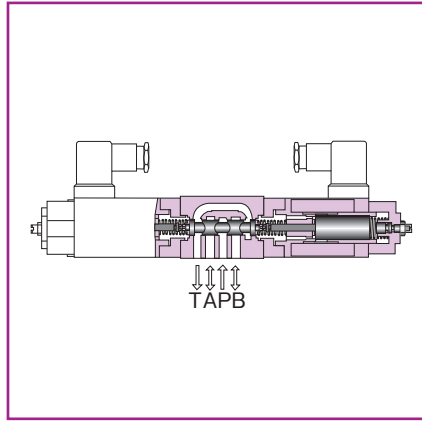
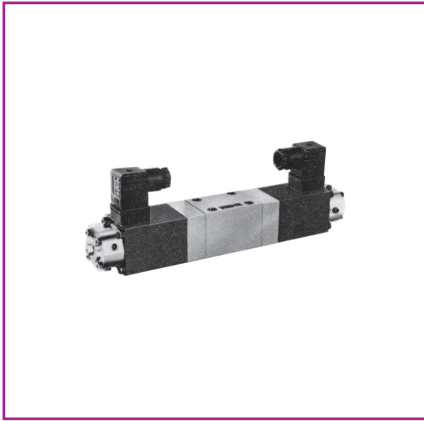

● Hydraulic symbols

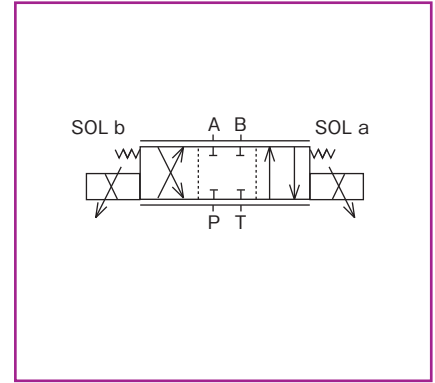

■ Overview

Direct operated type solenoid proportional control valve consists of DC proportional solenoids and spring balance type direct operated spool valve. The valve operating direction is selected by energizing either one of the two solenoids, and the flow amount is controlled by the open area of the spool that moves in proportion to the input current.

■ Features

1. During the initial adjustment or malfunction in the electrical system, manual operation can be done with the manual adjustment thread.
2. The structure is simple and maintenance is easy.

■ Type indication

DDP 6 P - 10 - 05 / 25 A B -

Direct operated type solenoid proportional control valve

Nominal dimension
6

Connection method
P = Gasket connection type

Series number: 10

Spool type
05, 13, 23 = Double solenoid type
05A, 05B, 13A, 13B, 23A, 23B = Single solenoid type
* Refer to page 6-22 "Spool type symbols"

Type of hydraulic oil
No symbol = Mineral based hydraulic oil
V = Phosphate ester based hydraulic oil
W = Fatty ester based hydraulic oil
Water-glycol based hydraulic oil

Electric connection symbol
B = DIN connector
C = DIN large connector

Solenoid ratings
A = 33Ω×0.75A
B = 7.2Ω×1.5A

Rated flow rate (When ΔP = 0.98 Mpa)
25 : 25 L / min
15 : 15 L / min
5 : 5 L / min

■ Specifications

Nominal dimension		6
Maximum working pressure MPa (kgf/cm ²)	Port P, A, B	30.9 (315)
	Port T	1.0 (10)
Rated flow rate L/min ΔP = 0.98 MPa per 1 round		25/15/5
Maximum differential pressure (Per one round) MPa (kgf/cm ²)		5.9 (60)
Maximum flow rate L/min		25/20/13
Reproducibility %		2
Hysteresis %		3
Step response ms	0→100% input	80
	100→0% input	50
Electrical specifications	Solenoid rated current mA	750/1,500
	Coil resistance Ω	33/7.2 at 20°C
	Dither (Recommendable value)	60Hz, 200/350mAP-P
	Standard amplifier type	C-B10-A ¹⁰⁰ / ₂₀₀ /C-B15-D24
Mass kg	Double solenoid type	2.6
	Single solenoid type	1.8

■ Sub-plate

Valve type	Sub-plate type	Connection diameter	Mass
DDP6	P-DE6R14-0	Rc 1/4	1.0kg
	P-DE6G14-0	G 1/4	
	P-DE6R38-0	Rc 3/8	1.3kg
	P-DE6G38-0	G 3/8	

When you use a sub-plate, please place an order for the above sub-plate type.
For the dimension drawing, refer to page 11 of the appendix.

■ Accessories

● Mounting bolt

Type	Hexagon socket head cap thread	Quantity	Tightening torque N · m (kgf · cm)
DDP6	M5×50L	4 pcs.	6.9 ± 1.0 (70 ± 10.5)

Current - Flow rate characteristics (viscosity 25 mm²/s (cSt))

DDP6

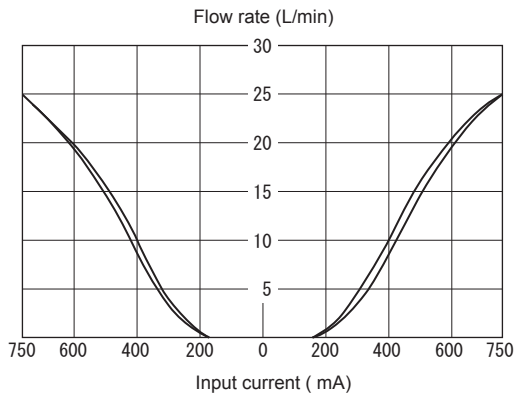

Primary pressure : 20.6 MPa (210 kgf/cm²)
 Dither : 60 Hz, 200 mAP-P
 Amount of pressure drop : 0.98 MPa (10 kgf/cm²)
 Per one round

Step response characteristics (viscosity 25 mm²/s (cSt))

DDP6

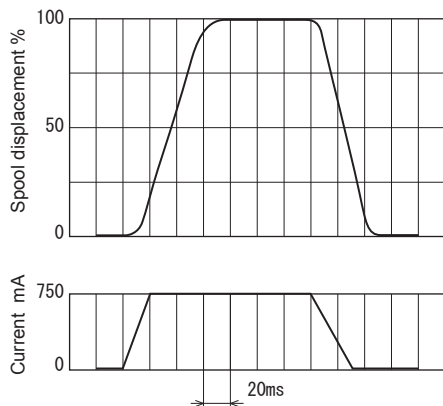

Primary pressure : 20.6 MPa (210 kgf/cm²)
 Dither : 60 Hz, 200 mAP-P

Dimension drawing

DDP6

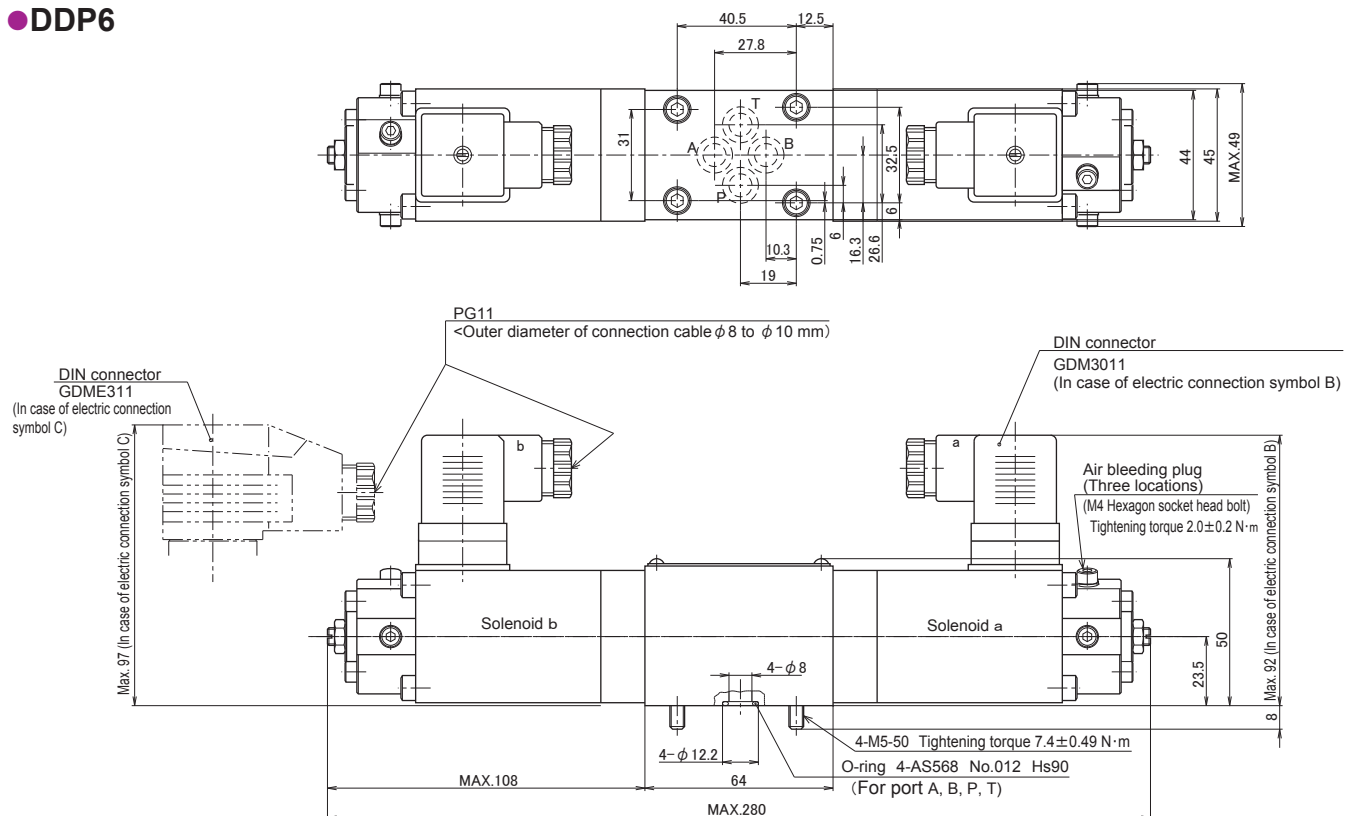

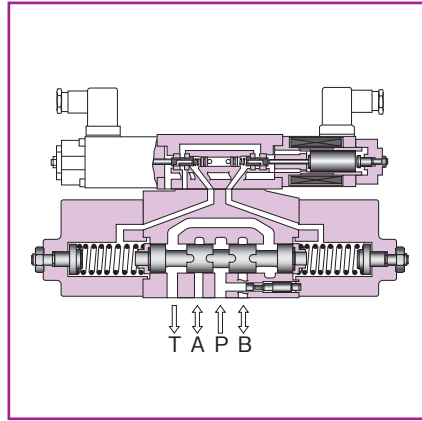
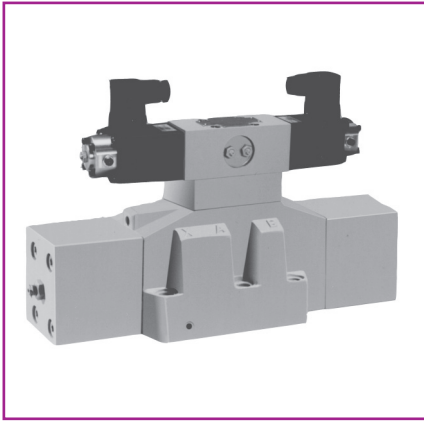

Solenoid proportional control valve – 2-stage amplifier type

Overview

2-stage amplifier type solenoid proportional control valve consists of proportional solenoid pilot pressure reducing valve and pilot pressure - spring balance type spool valve. The valve operating direction is selected by energizing either one of the two solenoids, and flow rate is controlled by the open area of the spool that moves in proportion to the input current.

Features

1. The right and left secondary pressure of the pilot valve can be adjusted independently and the spring of the main valve spool can be adjusted externally. The valve can provide even flow rate for the left and right sides.
2. Special damping mechanism with a spring realises superior stability even when the primary pilot pressure is as high as 30.9 MPa (315 kgf/cm²).
3. The selection of external/internal pilot can be easily implemented by changing the selection plug.

Type indication

DHP 16 P - 10 - 05 / 180 E - A C -

2-stage amplifier type solenoid proportional control valve

Nominal dimension
16, 22

Connection method
P = Gasket connection type

Series number: 10

Spool type

Type of hydraulic oil

- No symbol = Mineral based hydraulic oil
- V = Phosphate ester based hydraulic oil
- W = Fatty ester based hydraulic oil
- Water-glycol based hydraulic oil

Electric connection symbol

- B = DIN connector
- C = DIN large connector

Solenoid ratings

- A = 33Ω×0.75A
- B = 7.2Ω×1.5A

Pilot drain type

- No symbol = external pilot, external drain
- E = internal pilot, external drain
- ET = internal pilot, internal drain
- T = external pilot, internal drain

Rated flow rate (When ΔP = 0.98 Mpa)

- 16 size 35 : 35 L / min
- 100 : 100 L / min
- 180 : 180 L / min
- 22 size 300 : 300 L / min

Spool type	Hydraulic symbols
Double solenoid type	
Single solenoid type	

Specifications

Nominal dimension		16	22
Maximum working pressure MPa (kgf/cm ²)	Ports P, A, B, and X	30.9 (315)	
	Ports T	External drain	24.5 (250)
		Internal drain	1.0 (10)
	Ports Y	1.0 (10)	
Rated flow rate L/min (When valve pressure drop amount of $\Delta P = 0.98$ MPa)		180, 100, 35	300
Working pressure range MPa (kgf/cm ²)		2.5 to 30.9 (25 to 315)	
Lowest pilot pressure MPa (kgf/cm ²)		2.5 (25)	
Reproducibility %		2 or less	
Hysteresis %		3 or less	
Electrical specifications	Solenoid rated current mA	750/1,500	
	Coil resistance Ω	33/7.2 at 20°C	
	Dither (Recommendable value)	60Hz, 200/350 mAP-P	
	Standard amplifier type	C-B10-A ¹⁰⁰ / ₂₀₀ /C-B15-D24 (Single solenoid type) CW-B10-A ¹⁰⁰ / ₂₀₀ /CW-B15-D24 (Double solenoid type)	
Mass kg	Double solenoid type	15	22.5
	Single solenoid type	12	17.5

Sub-plate

Valve type	Sub-plate type	Connection diameter	Mass
DHP16	P-DEH16R34-0	Rc ³ / ₄	7.0kg
	P-DEH16G34-0	G ³ / ₄	
	P-DEH16R1-0	Rc 1	14.5kg
	P-DEH16G1-0	G1	
DHP22	P-DEH22R1-0	Rc 1	11kg
	P-DEH22G1-0	G1	
	P-DEH22R54-0	Rc1 ¹ / ₄	24kg
	P-DEH22G54-0	G1 ¹ / ₄	
	P-DEH22R32-0	Rc1 ¹ / ₂	
	P-DEH22G32-0	G1 ¹ / ₂	

When you use a sub-plate, please place an order for the above sub-plate type.
For the dimension drawing, refer to page 9, 10, and 11 of the appendix.

Accessories

Mounting bolt

Type	Hexagon socket head cap thread	Quantity	Tightening torque N · m (kgf · cm)
DHP16	M6 ×55L	2 pcs.	11.8 ± 1.7 (120 ± 18)
	M10×60L	4 pcs.	56.8 ± 8.5 (580 ± 87)
DHP22	M12×60L	6 pcs.	98.0 ± 14.7 (1000 ± 150)

Current - Flow rate characteristics (viscosity 25 mm²/s (cSt))

Primary pressure: 20.6 MPa (210 kgf/cm²), Dither: 60 Hz, 200 to 250 mAP-P, Amount of pressure drop: 0.98 MPa (10 kgf/cm²) Internal pilot, External drain

DHP16

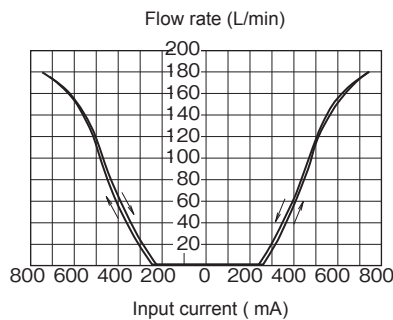

DHP22

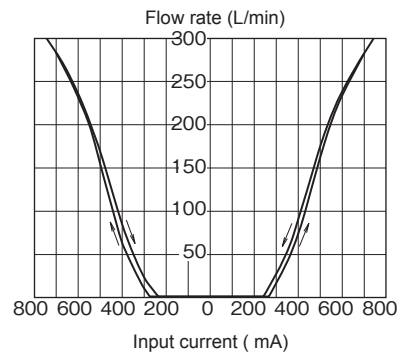

Step response characteristics (viscosity 25 mm²/s (cSt))

Primary pressure: 20.6 MPa (210 kgf/cm²), Internal pilot, External drain

DHP16

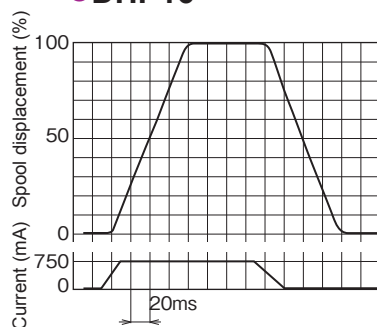

DHP22

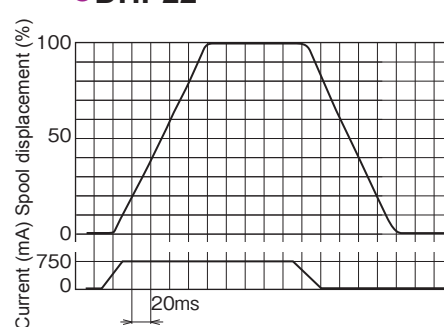

Dimension drawing

●DHP16 (Single solenoid type)

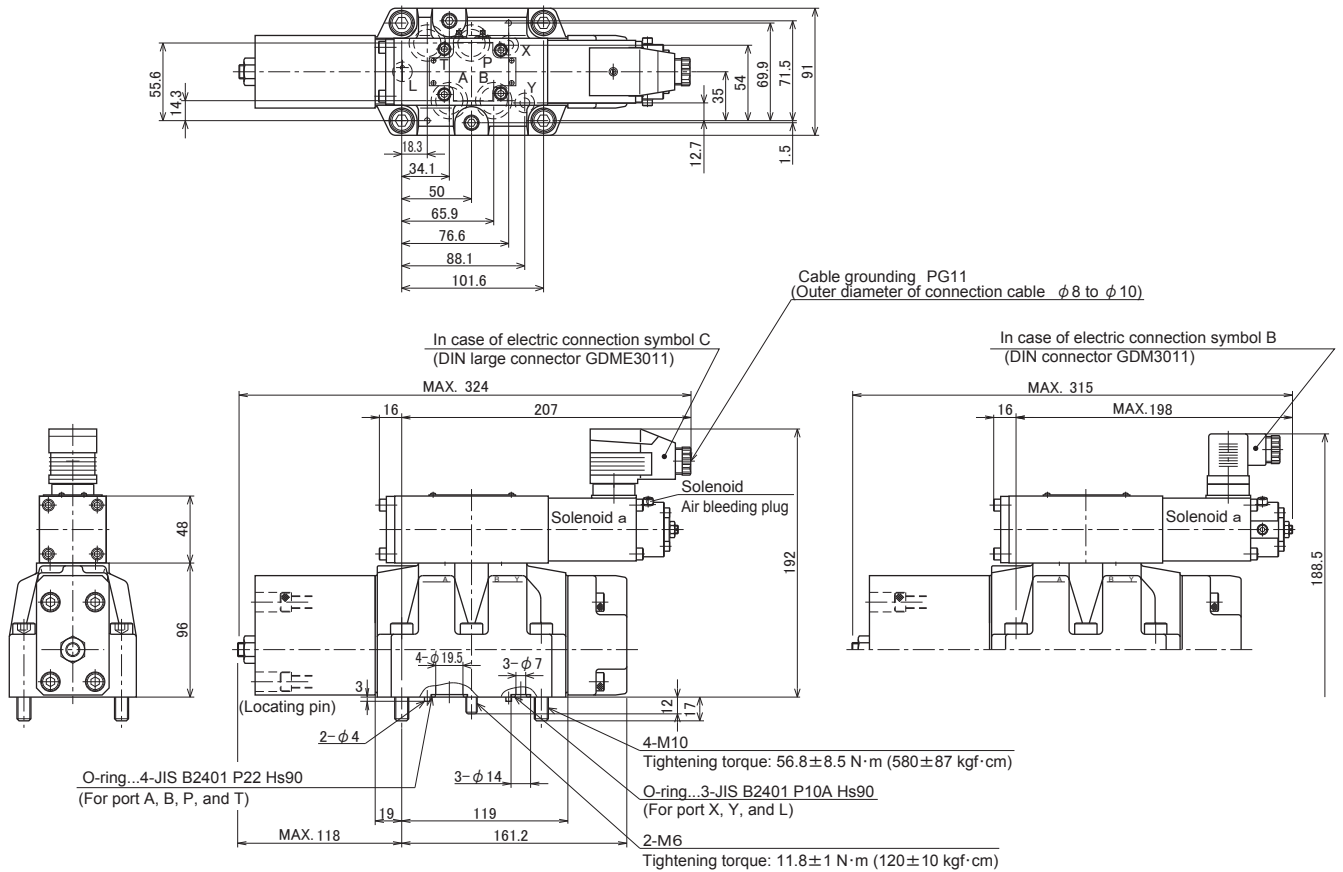

●DHP16 (Double solenoid type)

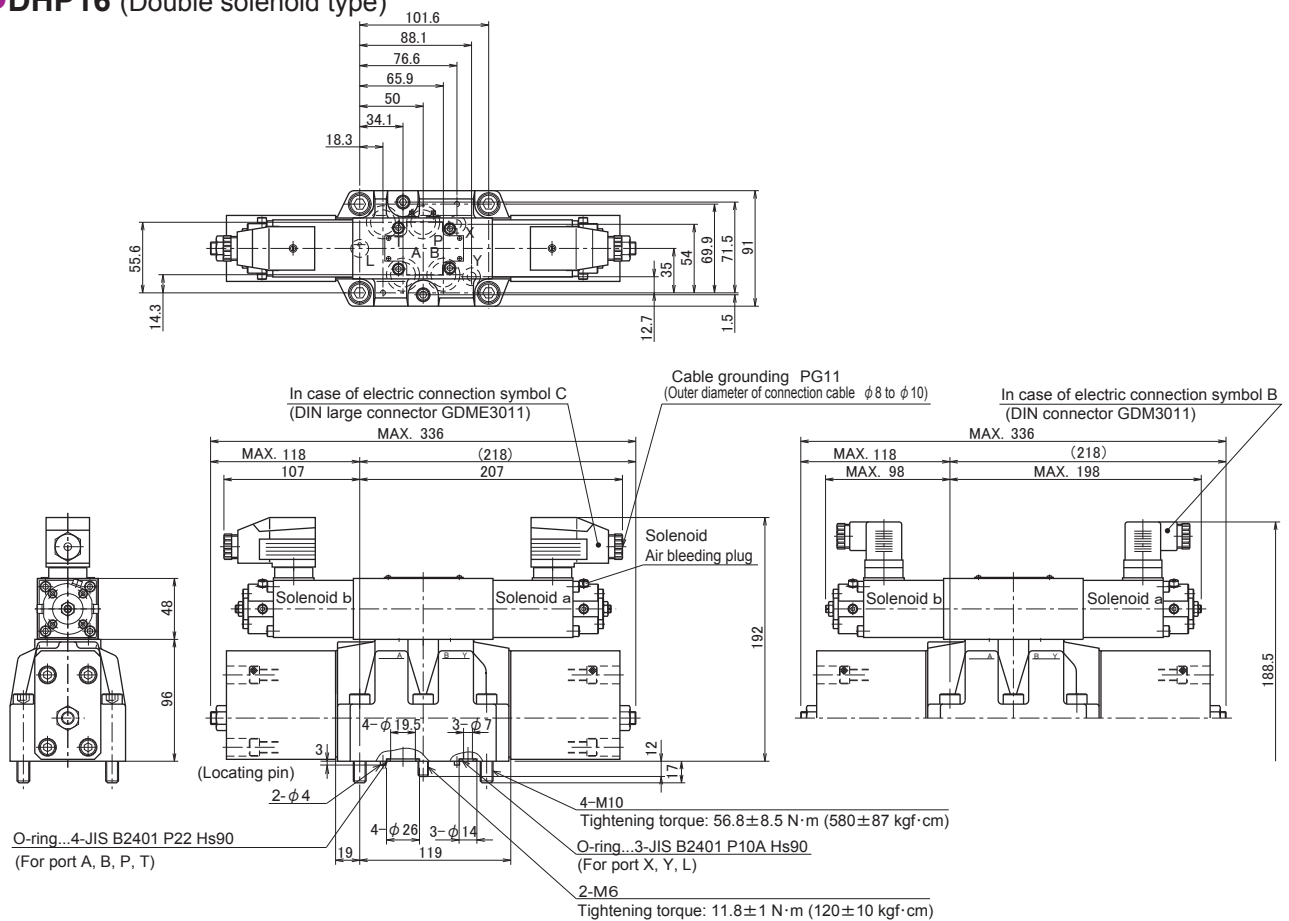

● **DHP22** (Single solenoid type)

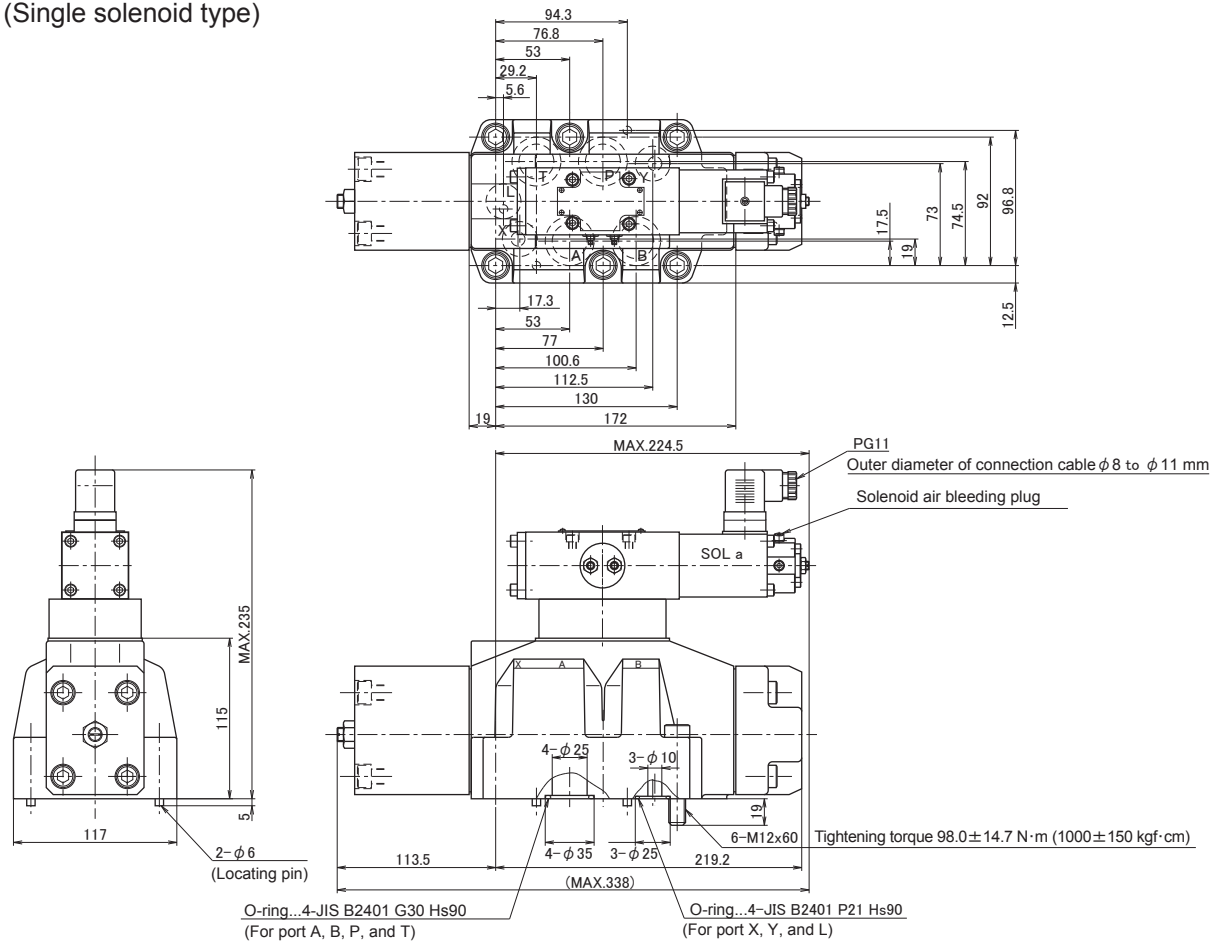

● **DHP22** (Double solenoid type)

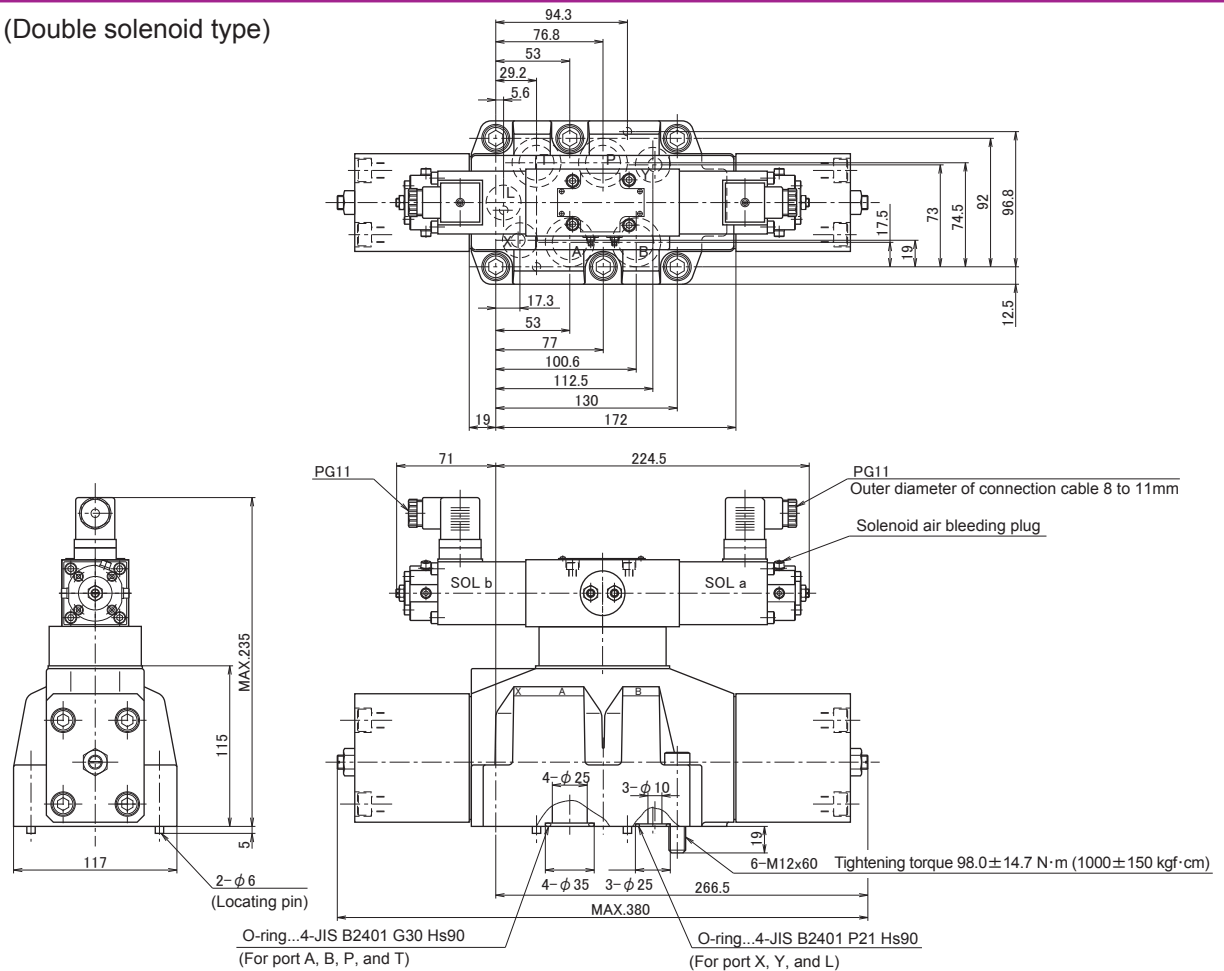

● Hydraulic symbols

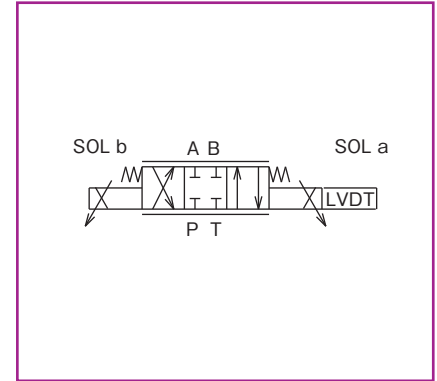

■ Features

1. It has high response and high accuracy, and high performance equivalent to those of a simple servo valve.
2. The dead zone for flow rate adjacent to the neutral point is small.
3. The structure is simple and maintenance is easy.

■ Overview

The valve is used with a special controller to allow operating direction and flow rate to be controlled in proportion to the controller input voltage.

Direct operated type solenoid proportional control valve consists of DC proportional solenoid with differential transformer (LVDT) and spring balance type spool valve, and spool displacement amount is detected by LVDT to make minor feedback.

■ Type indication

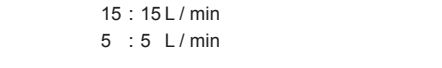

Type of hydraulic oil
 No symbol = Mineral based hydraulic oil
 V = Phosphate ester based hydraulic oil
 W = Fatty ester based hydraulic oil
 Water-glycol based hydraulic oil

Electric connection symbol
 B = DIN connector
 C = DIN large connector

Solenoid ratings
 B = 7.2Ω×1.5A

Rated flow rate (When ΔP=0.98Mpa)
 25 : 25 L / min
 15 : 15 L / min
 5 : 5 L / min

■ Sub-plate

Valve type	Sub-plate type	Connection diameter	Mass
DDPL6	P-DE6R14-0	Rc $\frac{1}{4}$	1.0kg
	P-DE6G14-0	G $\frac{1}{4}$	
	P-DE6R38-0	Rc $\frac{3}{8}$	1.3kg
	P-DE6G38-0	G $\frac{3}{8}$	

When you use a sub-plate, please place an order for the above sub-plate type.
 For the dimension drawing, refer to page 11 of the appendix.

■ Accessories

● Mounting bolt

Type	Hexagon socket head cap thread	Quantity	Tightening torque N · m (kgf · cm)
DDPL6	M5×50L	4 pcs.	6.9±1.0 (70±10.5)

Solenoid proportional control valve – Direct operated type, with LVDT

Specifications

Nominal dimension		6
Maximum working pressure MPa (kgf/cm ²)	Port P, A, B	30.9 (315)
	Port T	1.0 (10)
Rated flow rate L/min $\Delta P=0.98$ MPa per 1 round		25/15/5
Maximum differential pressure (Per one round) MPa (kgf/cm ²)		5.9 (60)
Maximum flow rate L/min		30/25/18
Reproducibility %		1 or less
Hysteresis %		1 or less
Step response ms	0→100% input	30
	100→0% input	18
Frequency response Hz ($\pm 2\%$ input)	-3dB	20
	90 degree delay	22
Electrical specifications	Solenoid rated current mA	1,500
	Coil resistance Ω	7.2 at 20°C
	Dither (Recommendable value)	60Hz, 200mAP-P
	Standard amplifier type	CFW-B15-D24
Mass kg	Double solenoid type	3.2
	Single solenoid type	2.3

Voltage - Flow rate characteristics (viscosity 25 mm²/s (cSt))

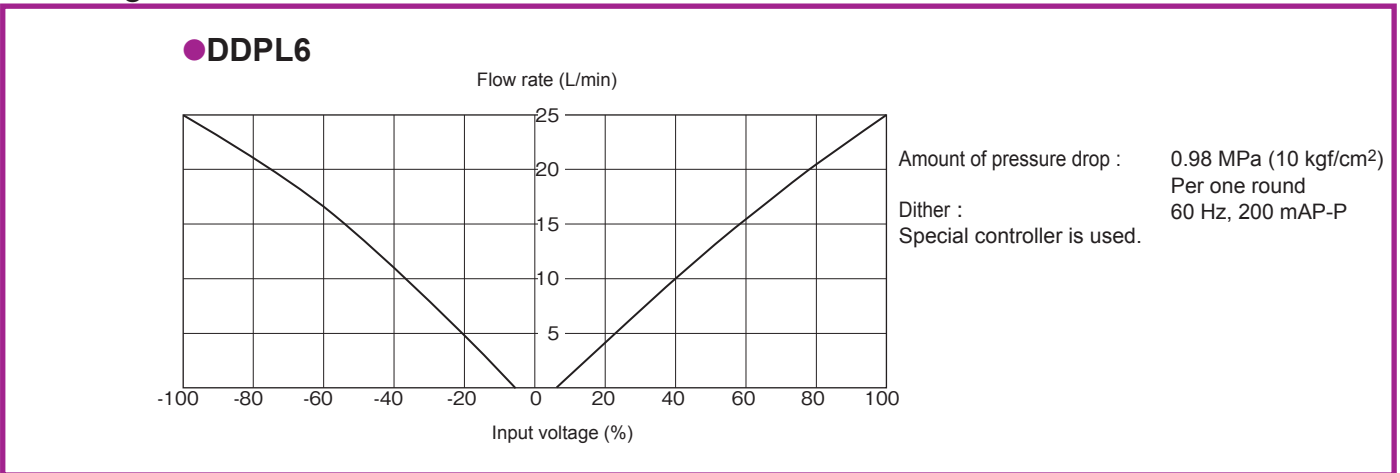

Step response characteristics (viscosity 25 mm²/s (cSt))

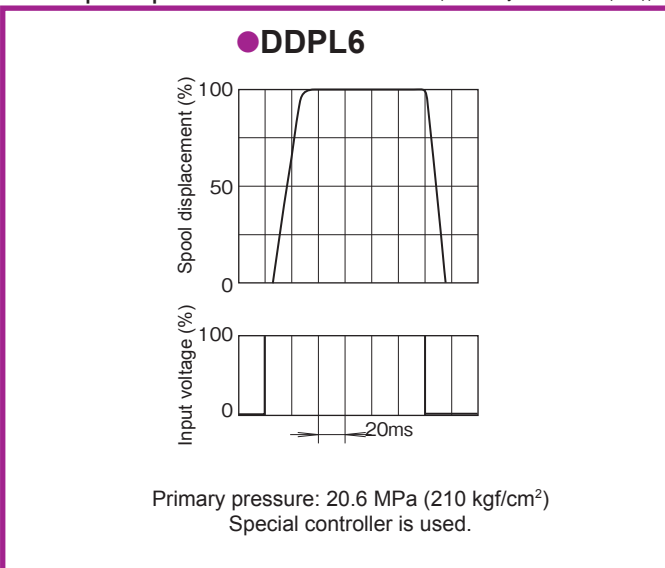

Frequency response characteristics (viscosity 25 mm²/s (cSt))

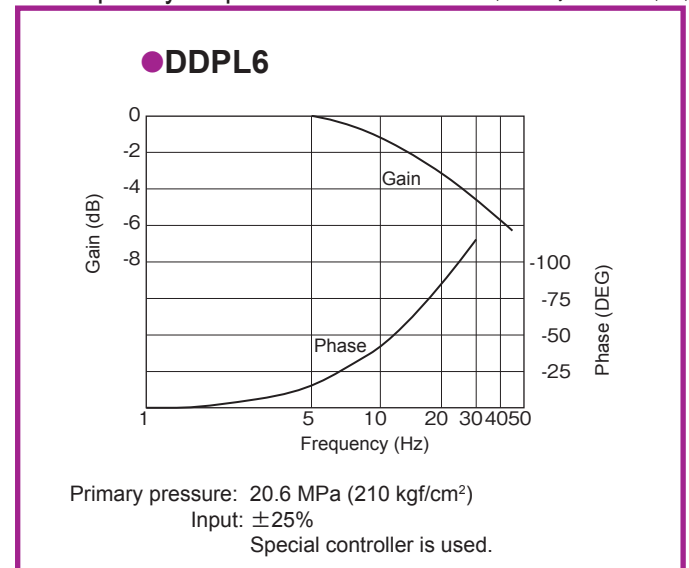

Dimension drawing

● DDPL6

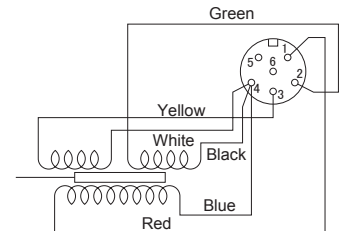
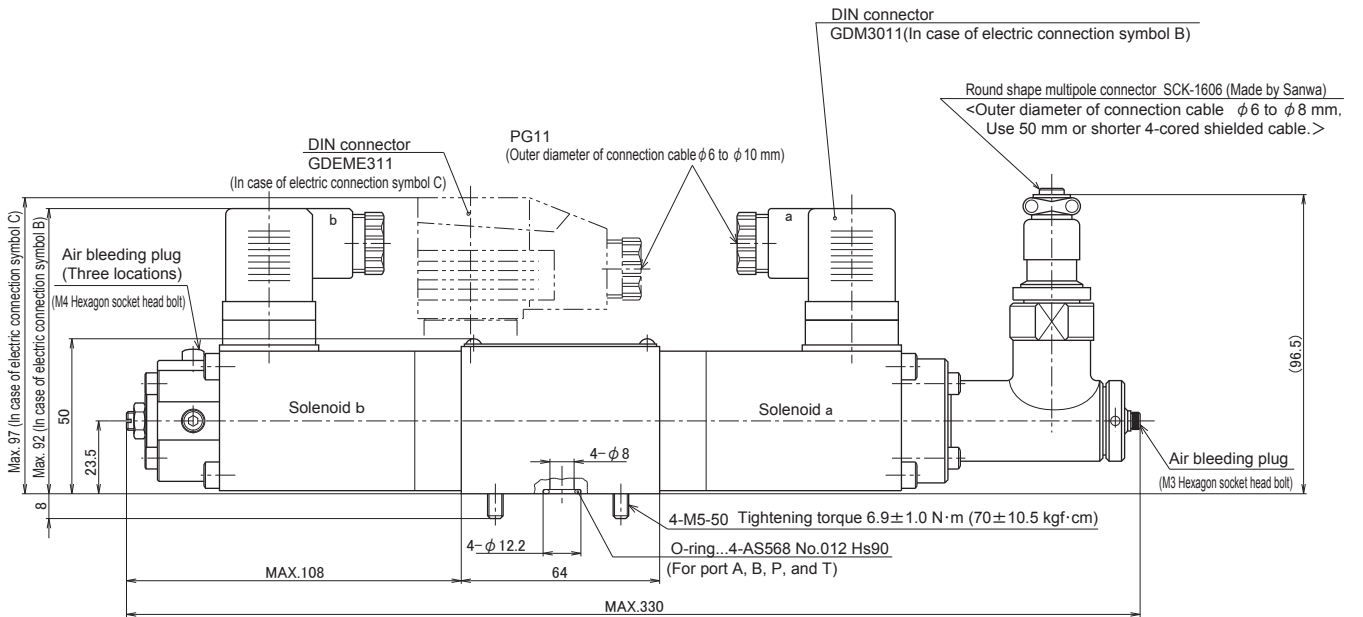
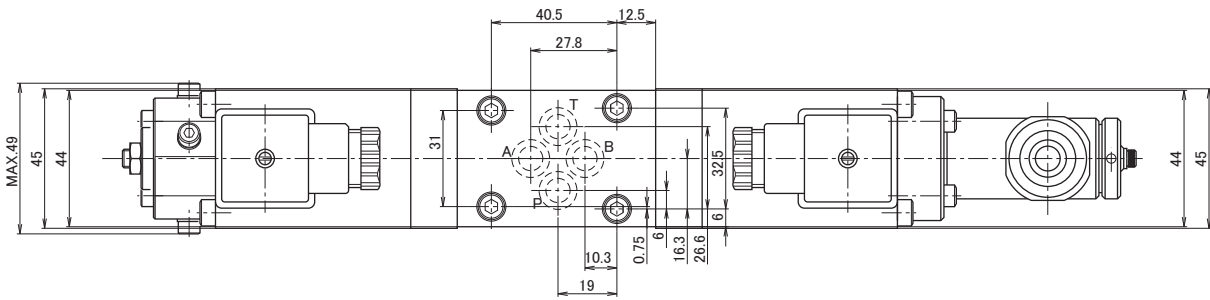

Connection diagram for differential transformer (LVDT) connector pins

Solenoid proportional control valve - Direct operated type, with LVDT

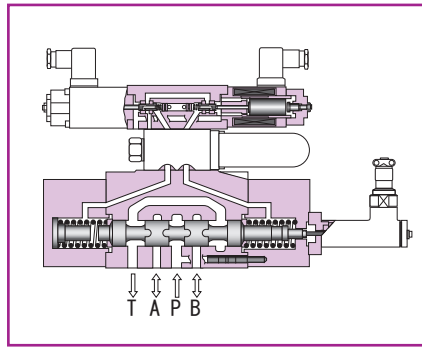
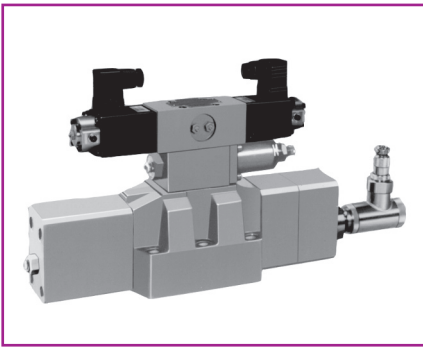

Hydraulic system

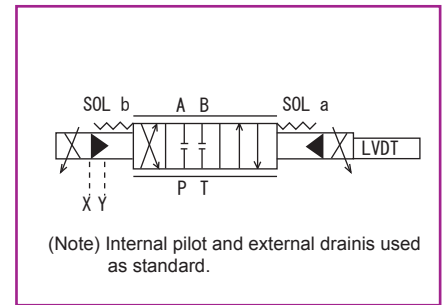

Overview

Solenoid proportional control valve consists of solenoid proportional pilot pressure reducing valve, sandwich type pressure reducing valve, spool type main valve, and differential transformer (LVDT). The spool displacement

amount is detected by LVDT to make minor feedback.

The valve is used with a special controller to allow operating direction and flow rate to be controlled in proportion to the input voltage.

Features

1. It shows high response and high accuracy control performance.
2. The structure is simple and maintenance is easy.

Type indication

DHPL 16 P - 10 - 05 / 180 E - B B -

- Solenoid proportional 2-stage amplifier type control valve with LVDT**
- Nominal dimension 16**
- Connection method P = Gasket connection type**
- Series number: 10**
- Spool type**
 - 05, 13, 23 = Double solenoid type
 - 05A, 05B, 13A, 13B, 23A, 23B = Single solenoid type
 - * Refer to page 6-22 "Spool type symbols".
- Type of hydraulic oil**
 - No symbol = Mineral based hydraulic oil
 - V = Phosphate ester based hydraulic oil
 - W = Fatty ester based hydraulic oil
 - Water-glycol based hydraulic oil
- Electric connection symbol**
 - B = DIN connector
 - C = DIN large connector
- Solenoid ratings**
 - B = 7.2Ω × 1.5A
- Pilot drain type**
 - No symbol = external pilot, external drain
 - E = internal pilot, external drain
 - ET = internal pilot, internal drain
 - * At least 2.5 MPa (25kgf/cm²) is required for either internal or external pilot pressure.
- Rated flow rate (When ΔP=0.98MPa)**
 - 100 : 100 L / min
 - 180 : 180 L / min
 - 35 : 35 L / min

Sub-plate

Valve type	Sub-plate type	Connection diameter	Mass
DHPL 16	P-DEH16R34-0	Rc 3/4	7.0kg
	P-DEH16G34-0	G 3/4	
	P-DEH16R1-0	Rc1	14.5kg
	P-DEH16G1-0	G1	

When you use a sub-plate, please place an order for the above sub-plate type.

For the dimension drawing, refer to page 11 of the appendix.

Accessories

Mounting bolt

Type	Hexagon socket head cap thread	Quantity	Tightening torque N · m (kgf · cm)
DHPL 16	M6 × 55L	2 pcs.	11.8 ± 1.7 (120 ± 18)
	M10 × 60L	4 pcs.	56.8 ± 8.5 (580 ± 87)

Specifications

Nominal dimension		16	
Maximum working pressure MPa (kgf/cm ²)	Ports P, A, B, and X	30.9 (315)	
	Ports T	External drain	24.5 (250)
		Internal drain	1.0 (10)
	Ports T	1.0 (10)	
Rated flow rate L/min $\Delta P=0.98$ MPa per 1 round		180, 100, 35	
Reproducibility %		1.5 or less	
Hysteresis %		1.5 or less	
Step response ms	0→100% input	100	
	100→0% input	100	
Frequency response Hz ($\pm 2\%$ input)	-3dB	7	
	90 degree delay	5	
Electrical specifications	Solenoid rated current mA	1,500	
	Coil resistance Ω	7.2 at 20°C	
	Dither (Recommendable value)	60Hz, 50mAP-p	
	Standard amplifier type	CFW-B15-D24	
Mass kg		18.5	

Voltage - Flow rate characteristics (viscosity 25 mm²/s (cSt))

DHPL16

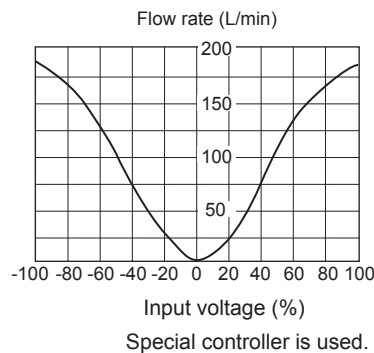

Primary pressure: 20.6 MPa (210 kgf/cm²)
 Amount of pressure drop : 0.98 MPa (10 kgf/cm²)
 Per one round
 Dither: 60 Hz, 350 mAP-P
 Internal pilot/external drain

Step response characteristics (viscosity 25 mm²/s (cSt))

DHPL16

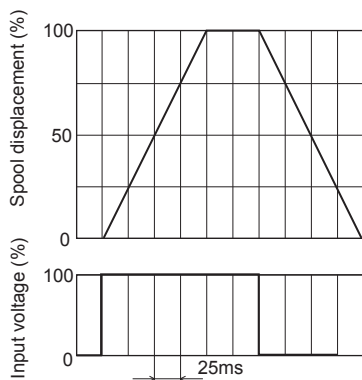

Primary pressure: 6.9 MPa (70 kgf/cm²) internal pilot/external drain
 Special controller is used.

Frequency response characteristics (viscosity 25 mm²/s (cSt))

DHPL16

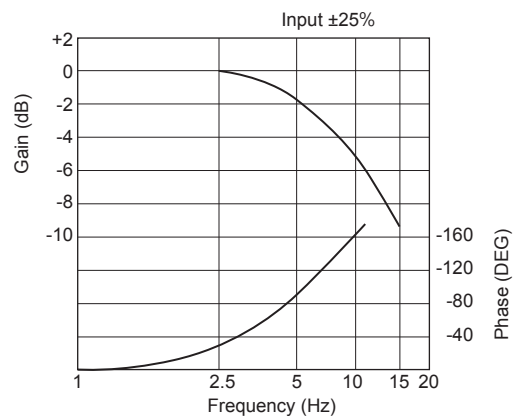

Primary pressure: 6.9 MPa (70 kgf/cm²) internal pilot/external drain
 Special controller is used.

Dimension drawing

●DHPL16

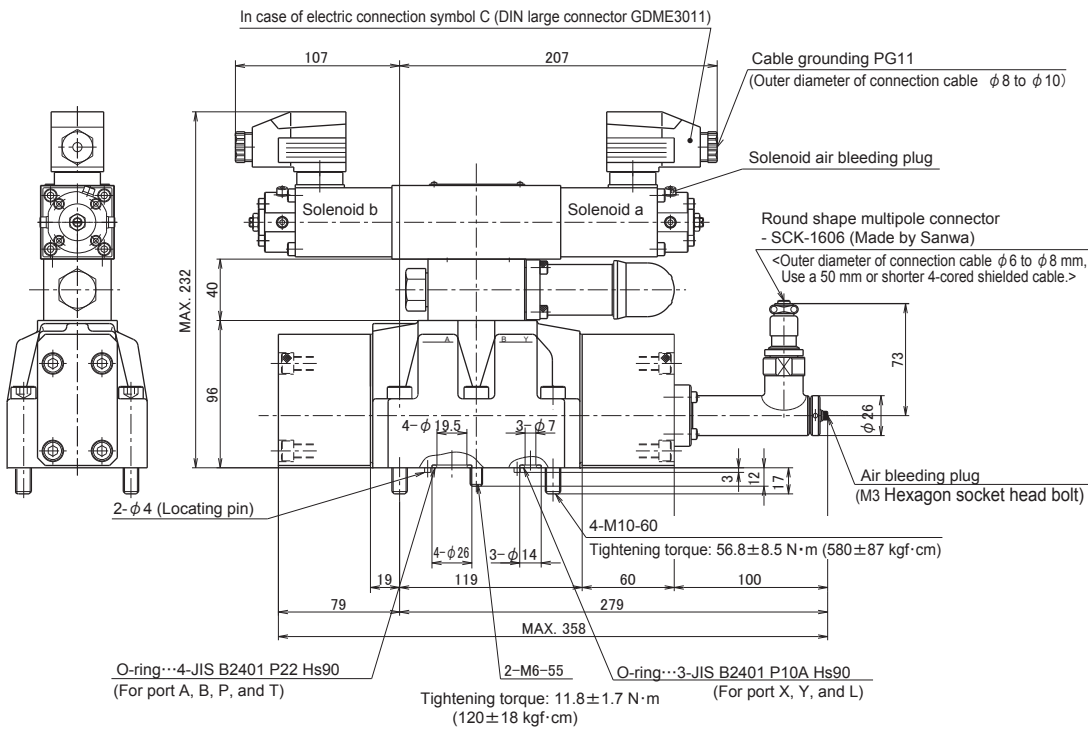
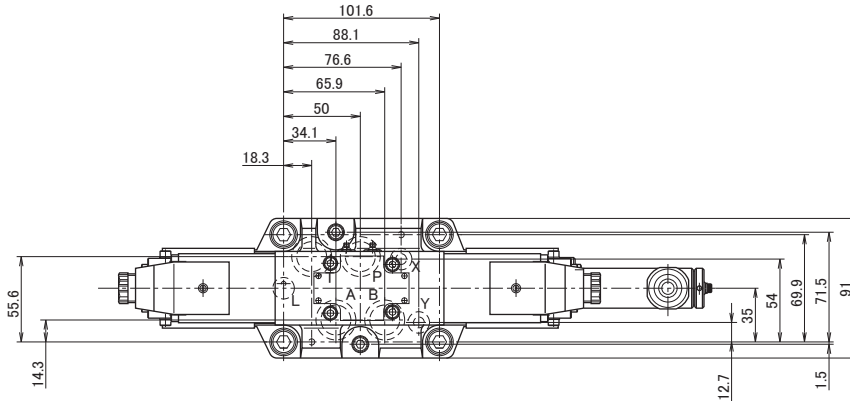

In case of electric connection symbol B (DIN connector GDM3011)

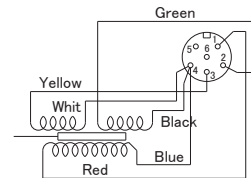
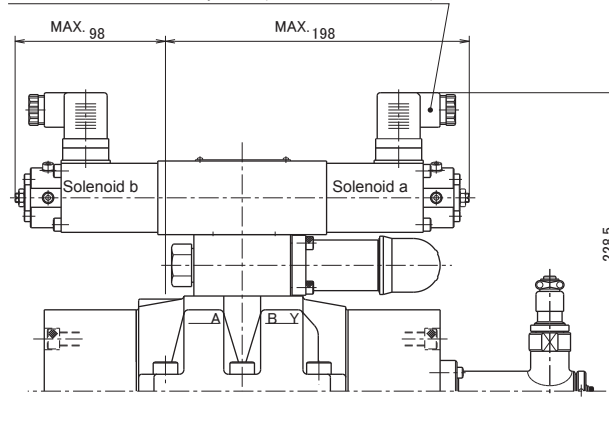

Connection diagram for differential transformer (LVDT) connector pins

Note : Port L is not used.

Controller

C series/C-B10-A

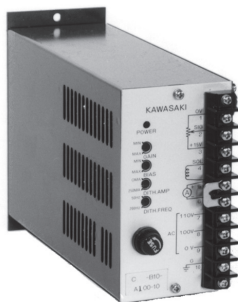

C series/C-B15-D

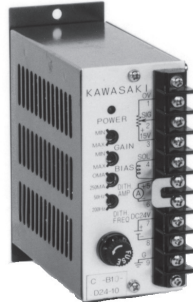

KC series/KC-B10

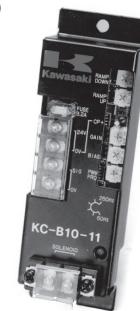

Overview

A controller exclusively used for driving solenoid proportional control valves

Features

1. Excellent constant current characteristics is obtained against the change of supply voltage, ambient temperature, and coil resistance.
2. The output current is PWM-controlled and the heat generation of the controller is extremely low, which makes it small and light weight.
3. As shown in List of Types, we line up various types to meet any usages.
4. KC seriee, the small size and inexpensive type is also lined up.

List of controller types and the applicable valve solenoid types

Controller						Applicable solenoid proportional control valves									
Series name	Driving method	Power supply	LVDT feedback	Single/double solenoid	Type	Solenoid relief valve		Solenoid proportional pressure reducing valve				Solenoid proportional control valve		LVDT solenoid proportional control valve (Proportional servo valve)	
						RDPV5	RBP10 to 5	PRDP6	PRBP10 to 30	PRDP1M6-S	PRDP1M6-D	DDP6	DHP16 to 22	DDPL6	DHPL16
C series	PWM + Dither Superposing type	AC power supply AC100/110V AC200/220V	Not provided	Single solenoid type	C-B10-A100/200	E	E	C	E	A	—	A	A	—	—
				Double solenoid type	CW-B10-A100/200	—	—	—	—	—	A	A	A	—	—
		DC power supply DC21 to 30V	Not provided	Single solenoid type	C-B15-D24	E	E	D	E	B	—	B	B	—	—
				Double solenoid type	CW-B15-D24	—	—	—	—	—	B	B	B	—	—
	Provided	Single solenoid type	CF-B15-D24	—	—	—	—	—	—	—	—	—	—	B	B
		Double solenoid type	CFW-B15-D24	—	—	—	—	—	—	—	—	—	—	B	B
KC series	PWM type	DC power supply DC21 to 30V	Not provided	Single solenoid type	KC-B10-11	E	E	—	E	—					

Type of the solenoid	Coil resistance (20°C)	Rated current
A	33Ω	750mA
B	7.2Ω	1,500mA
C	24Ω	750mA
D	6Ω	1,500mA
E	14.2Ω	800mA

■ Type indication

● C series

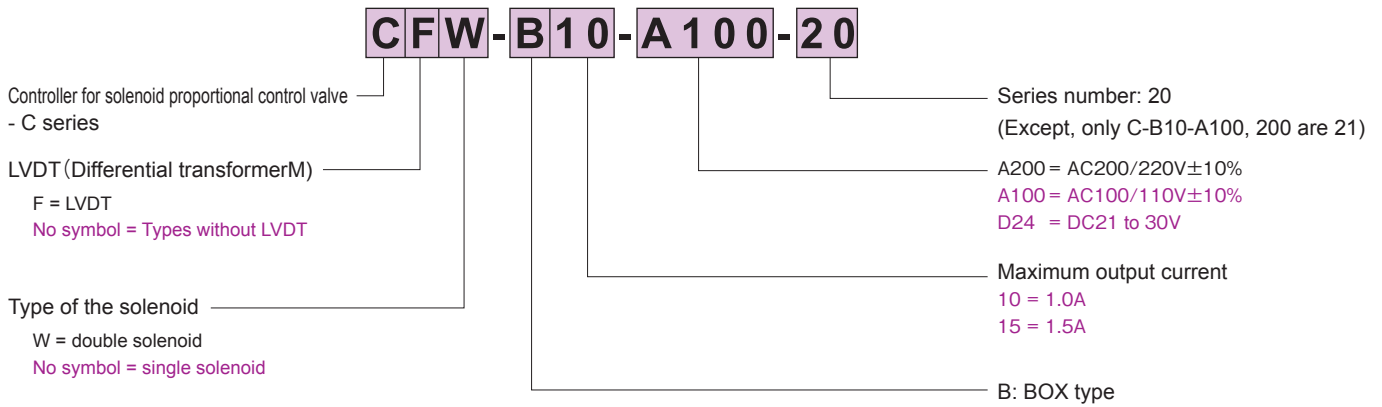

● KC series

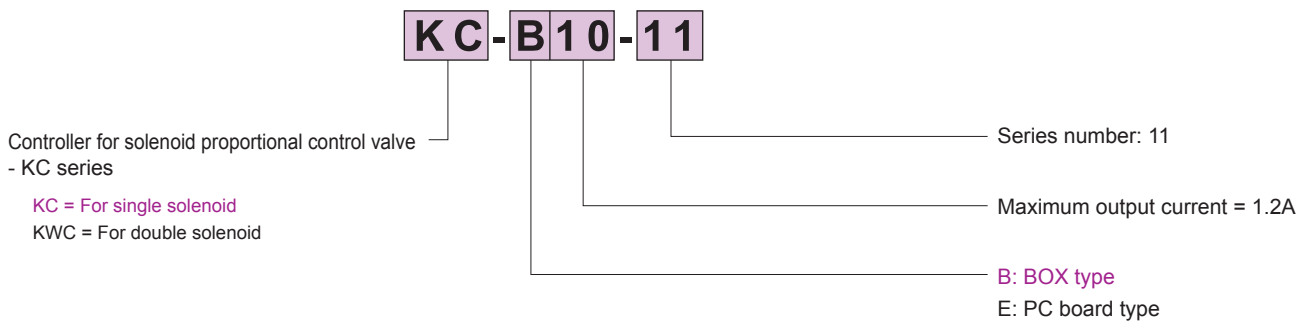

C series



Performance

Linearity	2% FS or below	
Step response	50 ms (0→100%)	
Constant current characteristic	Supply voltage fluctuation	1% FS or below ($\pm 10\%$)
	Change of load resistance	1.5% FS or below (33 to 45 Ω)
	Change of ambient temperature	1% FS or below (0 to 50°C)

(Note) Step response is measured while the solenoid is connected.
FS (Full Scale) means the rating of 750 mA.

Precautions in use

- This controller has internal heat generation. Do not install in a closed place. In addition, when more than one set are installed, keep the distance of 20 mm or more.
- Use a shielded cable for input signal wiring to protect it from noise.

Connection method

Please refer to the operation manual.

Specifications

Type		C-B10-A100-21	C-B10-A200-21
AC power supply (50/60 Hz)		AC100/110V $\pm 10\%$	AC200/220V $\pm 10\%$
Power consumption		40 VA or lower	
Solenoid coil resistance		45 Ω or lower	
Maximum output current		1.0 A	
Input impedance		50 k Ω	
Input command	Voltage input	DC0 to 10V max.	
	Resistance input	Variable resistance 5 k Ω (0.5 W or higher)	
Input gain adjustment		35 to 160 mA/V	
Dither adjustment	Frequency	50 to 200 Hz	
	Amplitude	0 to 250 mAP-P	
Bias adjustment		0 to 250 mA	
Ambient temperature and humidity		0 to 50°C, 90% RH or lower (No condensation)	
Vibration proof		Conforming to JIS C0911 IIB, Class-3 Frequency 16.7 Hz, amplitude 3 mm P-P	
Mass		3.1 kg	

Dimension drawing

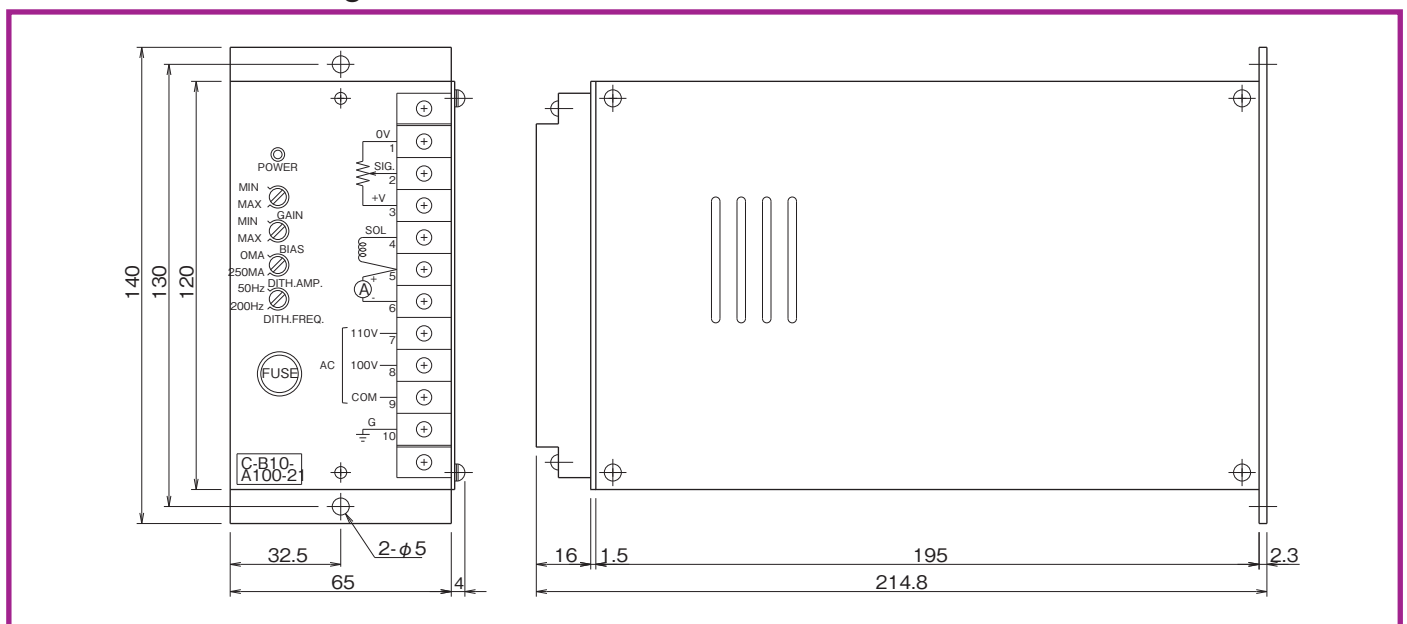

C series

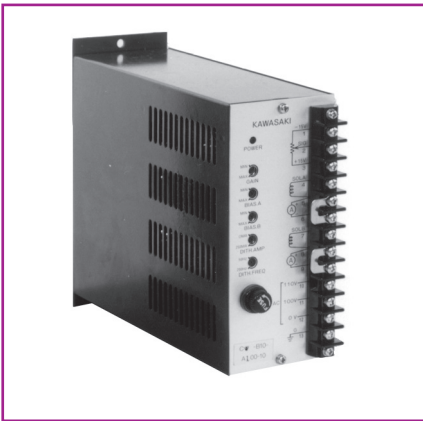

Performance

Linearity	2% FS or below	
Step response	50 ms(0→100%)	
Constant current characteristic	Supply voltage fluctuation	1% FS or below ($\pm 10\%$)
	Change of load resistance	1.5% FS or below (33 to 45 Ω)
	Change of ambient temperature	1% FS or below (0 to 50°C)

(Note) Step response is measured while the solenoid is connected.
FS (Full Scale) means the rating of 750 mA.

Precautions in use

- This controller has internal heat generation. Do not install in a closed place. In addition, when more than one set are installed, keep the distance of 20 mm or more.
- Use a shielded cable for input signal wiring to protect it from noise.

Connection method

Please refer to the operation manual.

Specifications

Type	CW-B10-A100-20	CW-B10-A200-20
AC power supply (50/60 Hz)	AC100/110 V $\pm 10\%$	AC200/220 V $\pm 10\%$
Power consumption	40VA or lower	
Solenoid coil resistance	45 Ω or lower	
Maximum output current	1.0 A	
Input impedance	50 k Ω	
Input command	Voltage input	DC0 to ± 10 Vmax.
	Resistance input	Variable resistance 5 k Ω (0.5 W or higher)
Input gain adjustment	35 to 160 mA/V	
Dither adjustment	Frequency	50 to 200 Hz
	Amplitude	0 to 250 mAP-P
Bias adjustment	0 to 250 mA	
Ambient temperature and humidity	0 to 50°C, 90% RH or lower (No condensation)	
Vibration proof	Conforming to JIS C0911 IIB, Class-3 Frequency 16.7 Hz, amplitude 3 mm P-P	
Mass	3.2 kg	

Dimension drawing

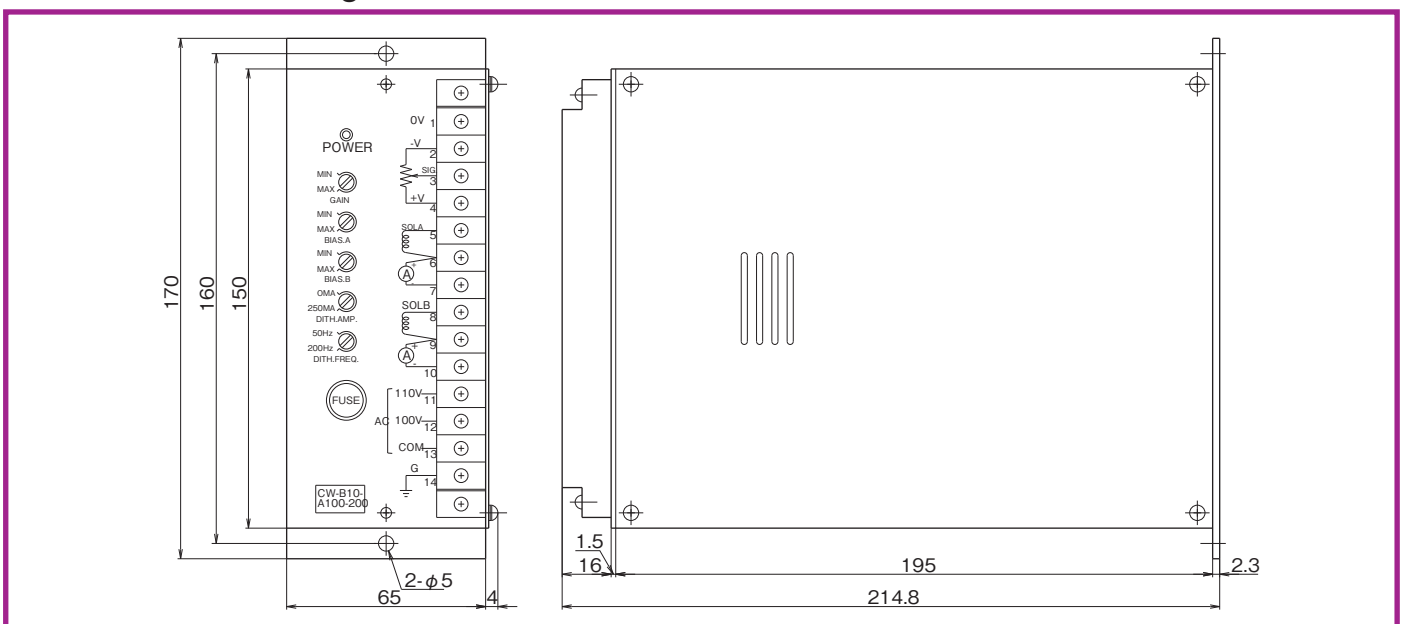

C series



Performance

Linearity	2% FS or below	
Step response	50 ms (0→100%)	
Constant current characteristic	Supply voltage fluctuation	1% FS or below (21 to 30 V)
	Change of load resistance	1.5% FS or below (5 to 11 Ω)
	Change of ambient temperature	1% FS or below (0 to 50°C)

(Note) Step response is measured while the solenoid is connected.
FS (Full Scale) means the rating of 1500 mA.

Precautions in use

- This controller has internal heat generation. Do not install in a closed place. In addition, when more than one set are installed, keep the distance of 20 mm or more.
- Use a shielded cable for input signal wiring to protect it from noise.

Connection method

Please refer to the operation manual.

Specifications

Type		C-B15-D24-20
DC power supply		DC24 V (21 to 30 V)
Power consumption		30 VA or lower
Solenoid coil resistance		11 Ω or lower
Maximum output current		1.5 A
Input impedance		50 kΩ
Input command	Voltage input	DC0 to 10 Vmax.
	Resistance input	Variable resistance 5 kΩ (0.5 W or higher)
Input gain adjustment		70 to 300 mA/V
Dither adjustment	Frequency	50 to 200 Hz
	Amplitude	0 to 450 mAP-P
Bias adjustment		0 to 500 mA
Ambient temperature and humidity		0 to 50°C, 90% RH or lower (No condensation)
Vibration proof		Conforming to JIS C0911 IIB, Class-3 Frequency 16.7 Hz, amplitude 3 mm P-P
Mass		0.5 kg

Dimension drawing

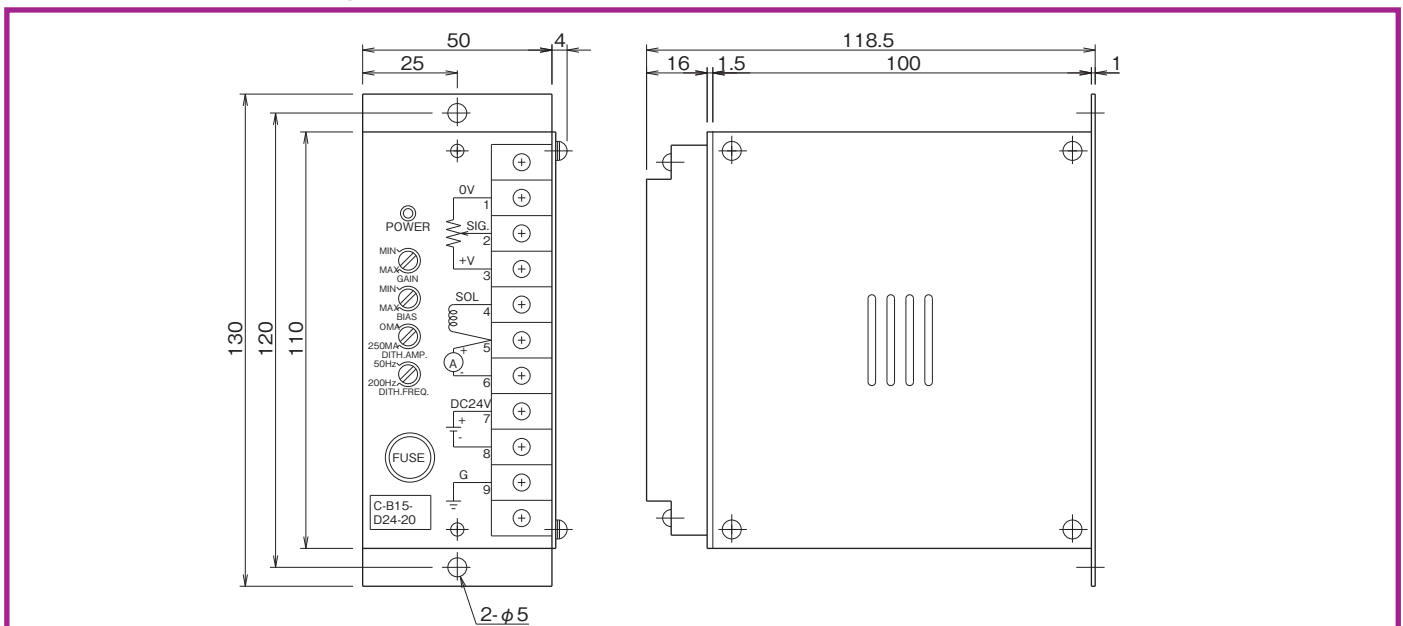

C series



Performance

Linearity	2% FS or below	
Step response	50ms (0→100%)	
Constant current characteristic	Supply voltage fluctuation	1% FS or below (21 to 30V)
	Change of load resistance	1.5% FS or below (5 to 11Ω)
	Change of ambient temperature	1% FS or below (0 to 50°C)

(Note) Step response is measured while the solenoid is connected.
FS (Full Scale) means the rating of 1500 mA.

Precautions in use

- This controller has internal heat generation. Do not install in a closed place. In addition, when more than one set are installed, keep the distance of 20 mm or more.
- Use a shielded cable for input signal wiring to protect it from noise.

Connection method

Please refer to the operation manual.

Specifications

Type		CW-B15-D24-20
DC power supply		DC24 V (21 to 30 V)
Power consumption		30 VA or lower
Solenoid coil resistance		11 Ω or lower
Maximum output current		1.5 A
Input impedance		50 kΩ
Input command	Voltage input	DC 0 to ±10 Vmax.
	Resistance input	Variable resistance 5 kΩ (0.5 W or higher)
Input gain adjustment		70 to 300 mA/V
Dither adjustment	Frequency	50 to 200 Hz
	Amplitude	0 to 450 mAP-P
Bias adjustment		0 to 500 mA
Ambient temperature and humidity		0 to 50°C, 90% RH or lower (No condensation)
Vibration proof		Conforming to JIS C0911 IIB, Class-3 Frequency 16.7 Hz, amplitude 3 mm P-P
Mass		0.7 kg

Dimension drawing

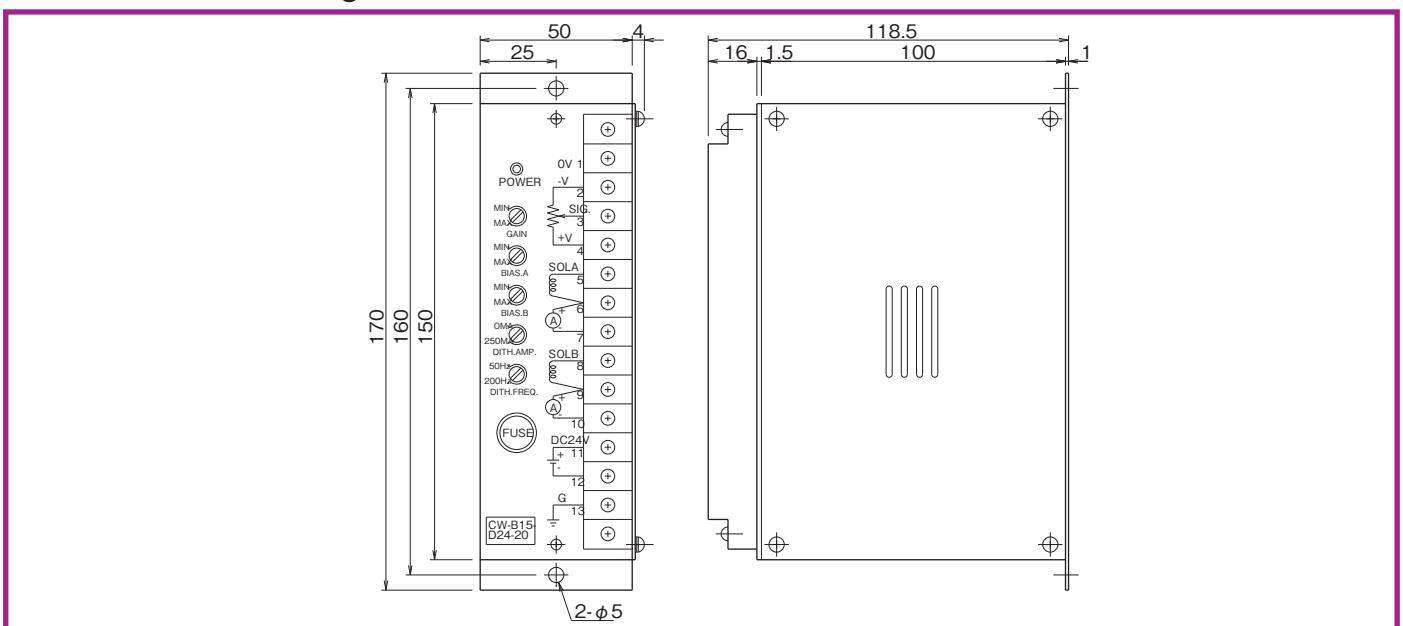

For DC power supply double solenoid

For DC power supply single solenoid with LVDT feedback **CF-B15-D**

C series

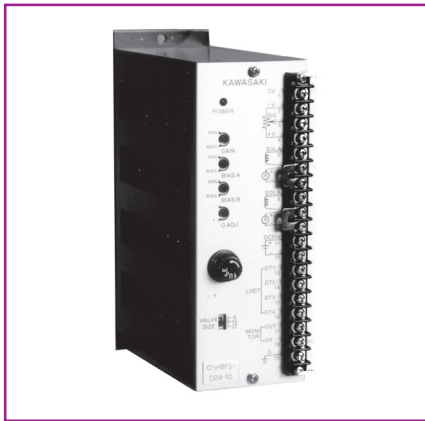

Performance

Linearity	2% FS or below	
Step response	30ms (0→100%)	
Constant current characteristic	Supply voltage fluctuation	1% FS or below (21 to 30 V)
	Change of load resistance	1.5% FS or below (5 to 11 Ω)
	Change of ambient temperature	1% FS or below (0 to 50°C)

(Note) Step response is measured while the solenoid is connected.
FS (Full Scale) means the rating of 1500 mA.

Precautions in use

- This controller has internal heat generation. Do not install in a closed place. In addition, when more than one set are installed, keep the distance of 20 mm or more.
- Use a shielded cable for input signal wiring to protect it from noise.
- Set the "VALVE SIZE" selection switch to the prescribed position corresponding to the valve size.

Specifications

Type		CF-B15-D24-20
DC power supply		DC24 V (21 to 30 V)
Power consumption		30 VA or lower
Solenoid coil resistance		11 Ω or lower
Maximum output current		1.5 A
Input impedance		50 kΩ
Input command	Voltage input	DC 0 to 10 Vmax.
	Resistance input	Variable resistance 5 kΩ (0.5 W or higher)
Input gain adjustment		70 to 300 mA/V
Dither adjustment	Frequency	Fixed
	Amplitude	Fixed
Bias adjustment		0 to 500 mA
Zero point adjustment		±20%FS
Monitor output (Spool displacement amount)		10 Vmax.
Ambient temperature and humidity		0 to 50°C, 90% RH or lower (No condensation)
Vibration proof		Conforming to JIS C0911 IIB, Class-3 Frequency 16.7 Hz, amplitude 3 mm P-P
Mass		0.8 kg

Connection method

Please refer to the operation manual.

Dimension drawing

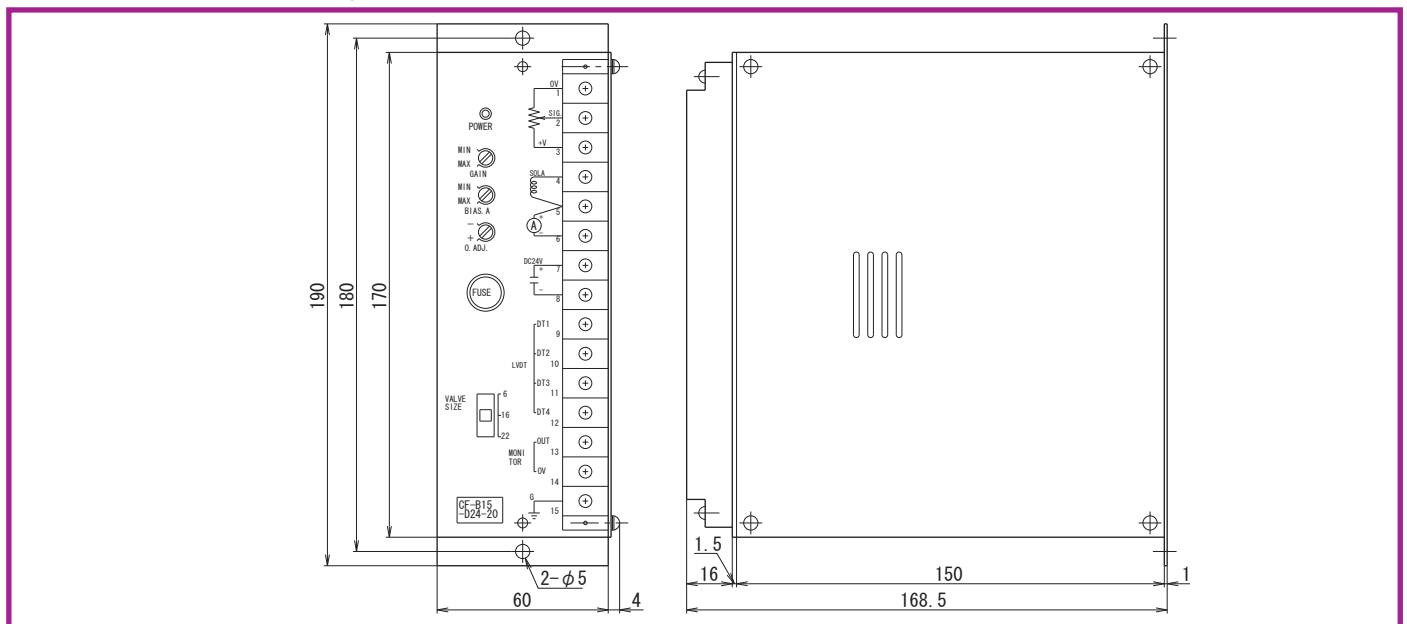

For DC power supply double solenoid with LVDT feedback **CFW-B15-D**

C series

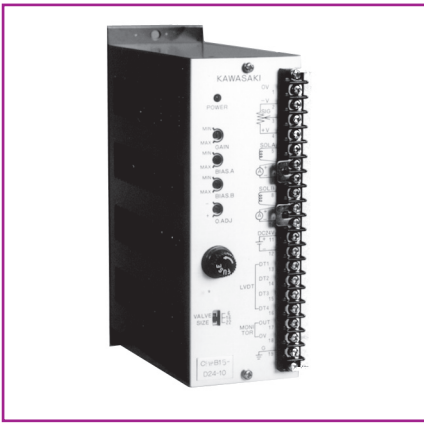

Performance

Linearity	2% FS or below	
Step response	30 ms (0→100%)	
Constant current characteristic	Supply voltage fluctuation	1% FS or below (21 to 30 V)
	Change of load resistance	1.5% FS or below (5 to 11 Ω)
	Change of ambient temperature	1% FS or below (0 to 50°C)

(Note) Step response is measured while the solenoid is connected.
FS (Full Scale) means the rating of 1500 mA.

Precautions in use

- This controller has internal heat generation. Do not install in a closed place. In addition, when more than one set are installed, keep the distance of 20 mm or more.
- Use a shielded cable for input signal wiring to protect it from noise.
- Set the "VALVE SIZE" selection switch to the prescribed position corresponding to the valve size.

Connection method

Please refer to the operation manual.

Specifications

Type	CFW-B15-D24-20	
DC power supply	DC24 V (21 to 30 V)	
Power consumption	30 VA or lower	
Solenoid coil resistance	11 Ω or lower	
Maximum output current	1.5 A	
Input impedance	50 kΩ	
Input command	Voltage input	DC 0 to ±10 Vmax.
	Resistance input	Variable resistance 5 kΩ (0.5 W or higher)
Input gain adjustment	70 to 300 mA/V	
Dither adjustment	Frequency	Fixed
	Amplitude	Fixed
Bias adjustment	0 to 500 mA	
Zero point adjustment	±20% FS	
Monitor output (Spool displacement amount)	10 Vmax.	
Ambient temperature and humidity	0 to 50°C, 90% RH or lower (No condensation)	
Vibration proof	Conforming to JIS C0911 IIB, Class-3 Frequency 16.7 Hz, amplitude 3 mm P-P	
Mass	1.0 kg	

Dimension drawing

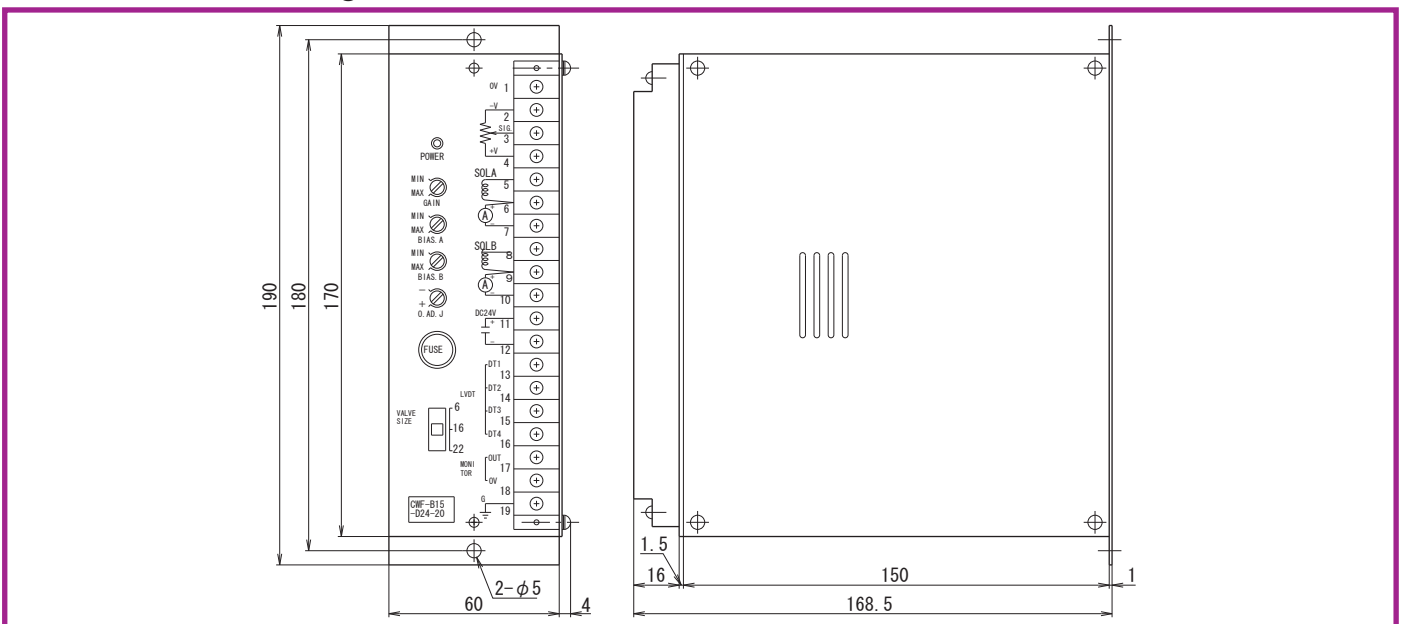

KC series



KWC series

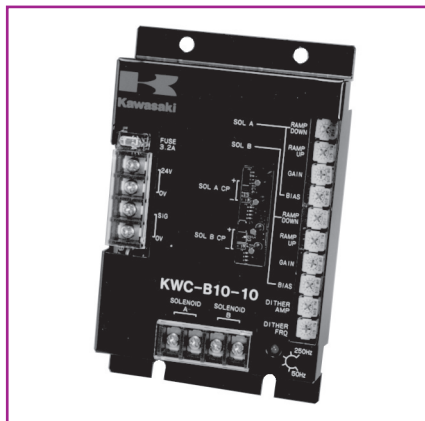

Performance

Linearity	2% FS or below	
Step response	100 ms (0→100%)	
Constant current characteristic	Supply voltage fluctuation	2% FS or less (21 to 31V)
	Change of load resistance	2% FS or less (14 to 21Ω)
	Change of ambient temperature	1.5% FS or less (0 to 50°C)

(Note) Step response is measured while the solenoid is connected.
FS (Full Scale) means the rating of 800 mA.

Precautions in use

- This controller has internal heat generation. Do not install in a closed place.
- Use a shielded cable for input signal wiring to protect it from noise.

Connection method

Please refer to the operation manual.

Accessories

Type: KC-B10-11
Spare fuse 1 piece

Type: KWC-B10-10
Spare fuse None

Specifications

Type		KC-B10-11	KWC-B10-10
Power supply		DC24 V (21 to 30 V)	
Power consumption		20 VA or lower	
Solenoid coil resistance		14 to 21 Ω or lower	
Maximum output current		1.0 A	
Input impedance		100 kΩ	
Input command	Voltage input	DC0 to 5 V (7.5 Vmax.)	DC0 to ±5 V (±7.5 Vmax.)
	Resistance input	Possible by connecting a set station KSA series	
Input gain adjustment		120 to 200 mA/V	
PWM frequency variable range		50 to 250 Hz	
Bias adjustment		0 to 400 mA	
Ramp adjustment		0.1 to 5 seconds (Adjustment up or down independently is possible)	
Voltage monitor (cp + terminal) output		0.47 V/ 1A	
Ambient temperature and humidity		0 to 50°C, 90% RH or lower (No condensation)	
Vibration proof		Conforming to JIS C5025 class A Sweeping frequency 10 to 55 Hz, amplitude 1.5 mm P-P	
Mass		90 g	160 g

Dimension drawing

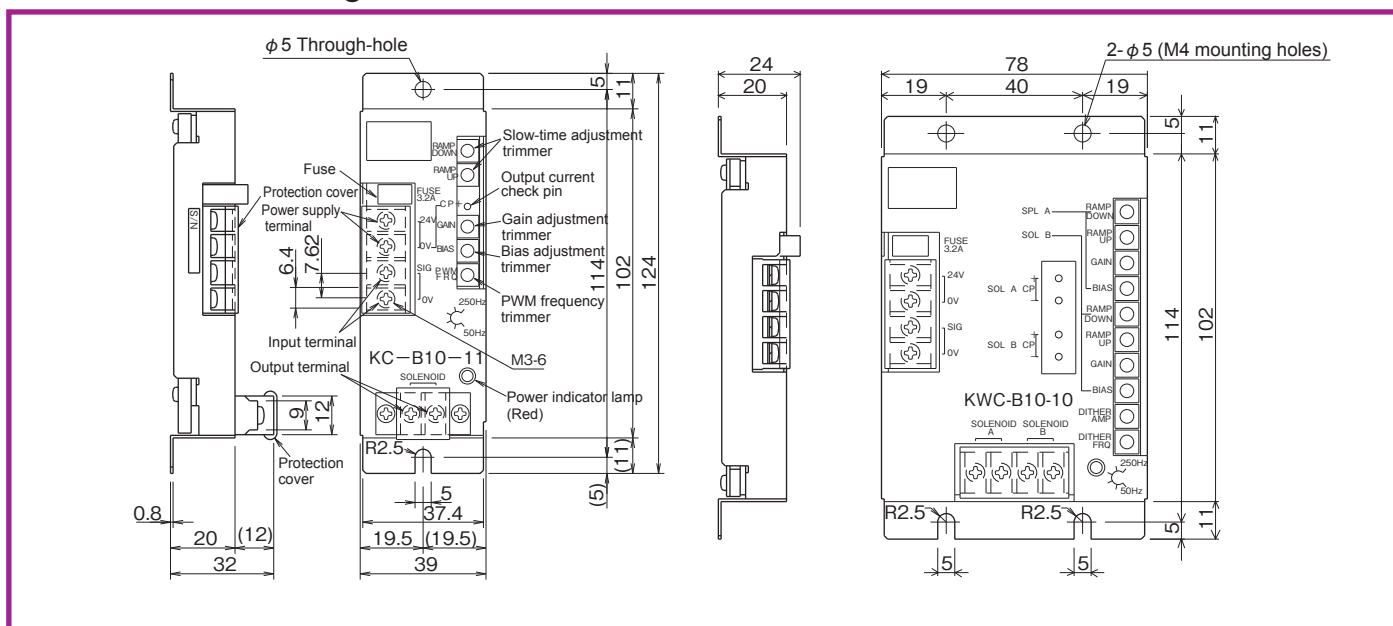

Sub-plate

When using the valve

- As for the sub-plates and flanges, please place an order separately, referring to the following application tables.
- We can manufacture sub-plates or flanges for the valve types other than those on the application tables. In such case, please contact us designating the valve type.

Type indication for Sub-plate

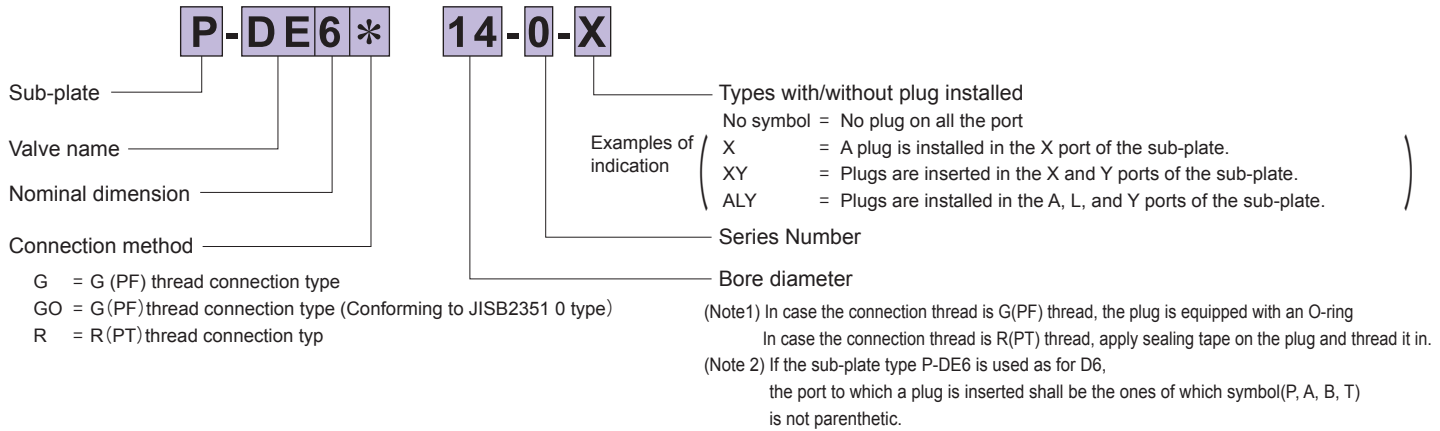

Sub-plates and Flange application tables

Directional control valve

Valve name	Nominal dimension	Sub-plate or flange		
		Type	Bore diameter	Stated page
DE DEH DH DM	6	P-DE6*14-0	1/4	Appendix-11
		P-DE6*38-0	3/8	
	10	P-DE10*38-0	3/8	Appendix-9
		P-DE10*12-0	1/2	
	16	P-DEH16*34-0	3/4	Appendix-11
		P-DEH16*1-0	1	
	22	P-DEH22*1-0	1	Appendix-9
		P-DEH22*54-0	1 1/4	
		P-DEH22*32-0	1 1/2	
	32	P-DEH32*32-0	1 1/2	Appendix-16
	52	TFAA-40	2	
		TFXA-40	2	
	62	TFAA-50	2 1/2	
		TFXA-50	2 1/2	
82	TFAA-63	3		
	TFXA-63	3		
102	TFAA-80	4		
	TFXA-80	4		
K4LA	6	P-DE6*14-0	1/4	Appendix-11
		P-DE6*38-0	3/8	
C	52	TFAA-40	2	Appendix-16
		TFXA-40	2	
	62	TFAA-50	2 1/2	
		TFXA-50	2 1/2	
	82	TFAA-63	3	
		TFXA-63	3	
	102	TFAA-80	4	
		TFXA-80	4	
	125	TFAA-125	6	
		TFXA-125	6	
150	TFAA-150	8		
	TFXA-150	8		

Valve name	Nominal dimension	Sub-plate or flange		
		Type	Bore diameter	Stated page
CH CHY	10	P-CHY10*14-0	1/4	Appendix-6
		P-CHY10*38-0	3/8	
		P-CHY10*12-0	1/2	
	20	P-CHY20*34-0	3/4	Appendix-7
		P-CHY20*1-0	1	
	30	P-CHY30*54-0	1 1/4	Appendix-7
P-CHY30*32-0		1 1/2		
52	TFAA-40	2	Appendix-16	
	TFXA-40	2		
62	TFAA-50	2 1/2		
	TFXA-50	2 1/2		
82	TFAA-63	3		
	TFXA-63	3		
102	TFAA-80	4		
	TFXA-80	4		
125	TFAA-125	6		
	TFXA-125	6		
150	TFAA-150	8		
	TFXA-150	8		

● Pressure control valve

Valve name	Nominal dimension	Sub-plate or flange			
		Type	Bore diameter	Stated page	
RD	6	P-RD6*14-0	1/4	Appendix-8	
	10	P-RD10*12-0	1/2		
	20	P-RD20*34-0	3/4		
		P-RD20*1-0	1		
	30	P-RD30*54-0	1 1/4		
		P-RD30*32-0	1 1/2		
RB RBE	10	P-RB10*14-0	1/4	Appendix-5	
		P-RB10*38-0	3/8		
		P-RB10*12-0	1/2		
	20	P-RB20*34-0	3/4	Appendix-6	
		P-RB20*1-0	1		
	30	P-RB30*54-0	1 1/4	Appendix-6	
		P-RB30*32-0	1 1/2		
	52	TFAA-40	2	Appendix-16	
		TFXA-40	2		
		82	TFAA-63		3
			TFXA-63		3
	PRD SD	6	P-DE6*14-0	1/4	Appendix-11
P-DE6*38-0			3/8		
10		P-CHY10*14-0	1/4	Appendix-6	
		P-CHY10*38-0	3/8		
PRB SB	10	P-CHY10*14-0	1/4	Appendix-6	
		P-CHY10*38-0	3/8		
		P-CHY10*12-0	1/2		
	20	P-CHY20*34-0	3/4	Appendix-7	
		P-CHY20*1-0	1		
	30	P-CHY30*54-0	1 1/4	Appendix-7	
P-CHY30*32-0		1 1/2			
PU PUE	10	P-PU10*38-0	3/8	Appendix-12	
		P-PU10*12-0	1/2		
	20	P-PU20*34-0	3/4	Appendix-13	
		P-PU20*1-0	1		
	30	P-PU30*54-0	1 1/4	Appendix-13	
		P-PU30*32-0	1 1/2		
3RBE	10	P-PB10*14-0	1/4	Appendix-5	
		P-PB10*38-0	3/8		
		P-PB10*12-0	1/2		
	20	P-PB20*34-0	3/4	Appendix-5	
		P-PB20*1-0	1		
	30	P-PB30*54-0	1 1/4	Appendix-6	
		P-PB30*32-0	1 1/2		

● Flow control valve

Valve name	Nominal dimension	Sub-plate or flange		
		Type	Bore diameter	Stated page
TC1M T1M	52	TFAA-40	2	Appendix-16
		TFXA-40	2	
	62	TFAA-50	2 1/2	
		TFXA-50	2 1/2	
	82	TFAA-63	3	
		TFXA-63	3	
102	TFAA-80	4		
	TFXA-80	4		
F	5	P-FJC5*14-0	1/4	Appendix-8
	10	P-F10*12-0	1/2	
FJC	5	P-FJC5*14-0	1/4	Appendix-4
	10	P-FJC10*12-0	1/2	
		P-FJC10*34-0	3/4	
	16	P-FJC16*1-0	1	
P-FJC16*54-0		1 1/4		
FJC	30	P-FJC30*54-0	1 1/4	Appendix-4
		P-FJC30*32-0	1 1/2	
FK	10	P-FK10*12-0	1/2	Appendix-12
	16	P-FK16*1-0	1	
		P-FK16X*1-0	1	

● Solenoid proportional control valve

Valve name	Nominal dimension	Sub-plate or flange		
		Type	Bore diameter	Stated page
RBP	10	P-RB10*4-0	1/4	Appendix-5
		P-RB10*38-0	3/8	
		P-RB10*2-0	1/2	
	20	P-RB20*34-0	3/4	
		P-RB20*1-0	1	
		30	P-RB30*54-0	
P-RB30*32-0	1 1/2			
PRBP	10	P-CHY10*14-0	1/4	Appendix-6
		P-CHY10*8-0	3/8	
		P-CHY10*12-0	1/2	
	20	P-CHY20*34-0	3/4	
		P-CHY20*1-0	1	
	30	P-CHY30*54-0	1 1/4	
P-CHY30*32-0		1 1/2		
PRDP PRDP1M DDP (L)	6	P-DE6*14-0	1/4	Appendix-11
		P-DE6*38-0	3/8	
DHP DHPL	16	P-DEH16*34-0	3/4	Appendix-11
		P-DEH16*1-0	1	
	22	P-DEH22*1-0	1	Appendix-9
		P-DEH22*54-0	1 1/4	
RDPV	5	P-DEH22*32-0	1 1/2	Appendix-10
		P-RDPV5*14-0	1/4	

●P-FJC30

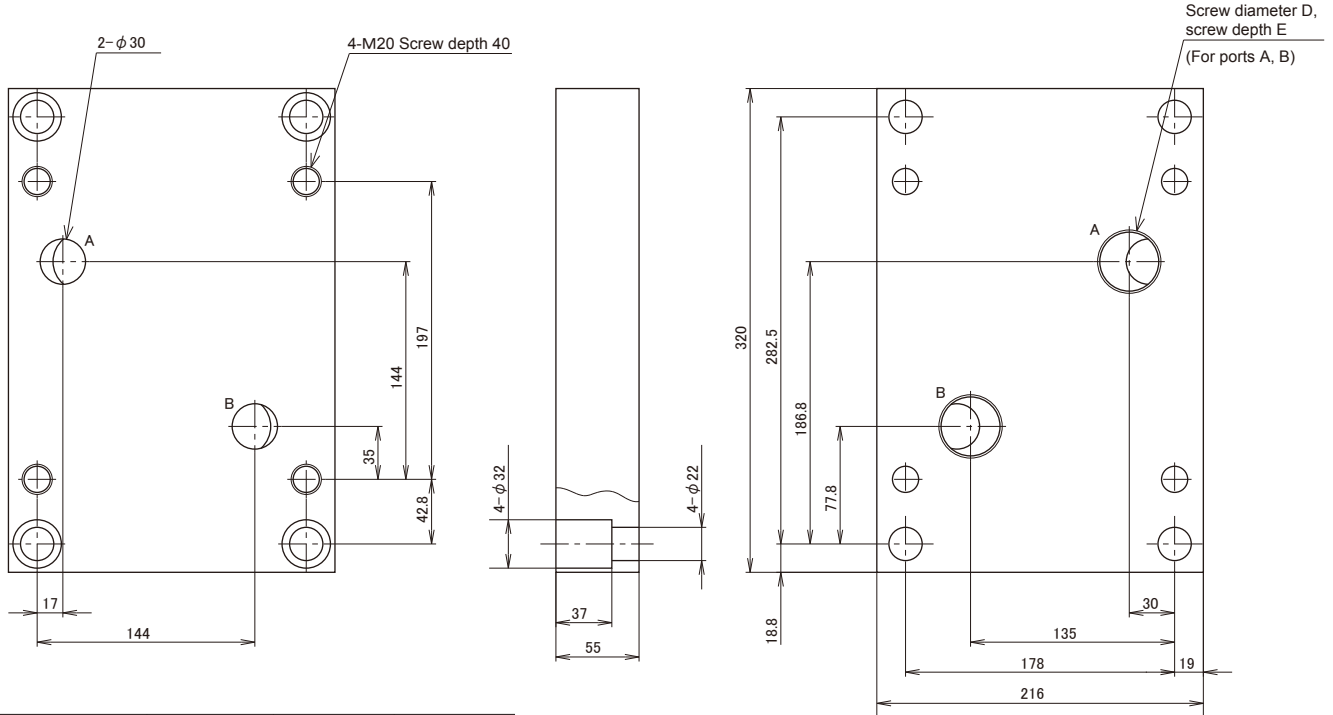

Type	D	E	Mass (kg)
P-FJC30G54-0	G1 1/4	28	28
P-FJC30R54-0	Rc1 1/4	24.5	
P-FJC30G32-0	G1 1/2	29	
P-FJC30R32-0	Rc1 1/2	25.5	

●P-FJC10, 16

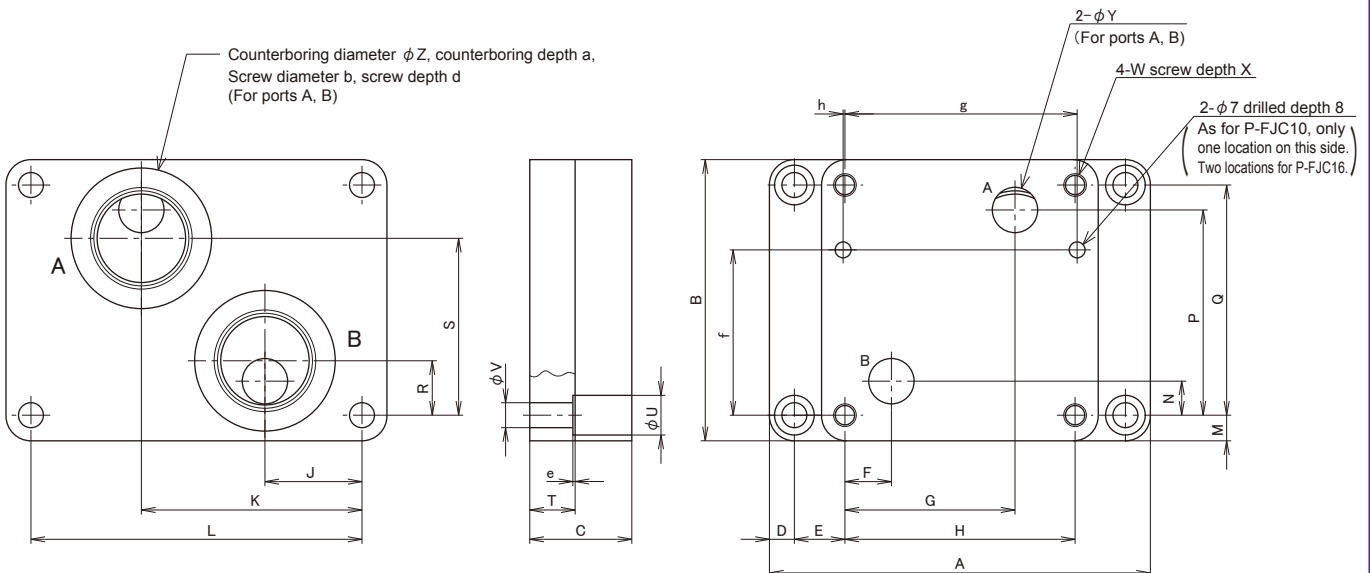

Type	A	B	C	D	E	F	G	H	J	K	L	M	N	P	Q	R	S	T	U	V	W	X	Y	Z	a	b	d	e	f	g	h	Mass (kg)	
P-FJC10G12-0			28														66.5	20				Through hole	42	1	G1 1/2	14						2	
P-FJC10R12-0	134.5	106.5		10.3	19	9.5	55	76	28.5	74	114	12	30	71.5	82.5	30			14	8.8	M8	15			Rc1 1/2	15	9	58.7	79.4				
P-FJC10G34-0			35														63.5	35				15				G3/4	18	24				3	
P-FJC10R34-0																											Rc3/4	19					
P-FJC16G1-0																								52	1	G1	19						
P-FJC16R1-0	168	124	45	11	22.3	20.5	75	101.5	42.8	97.3	146	11.3	15	90.5	101.5	24	78	20	17.5	11	M10	20				Rc1	22						
P-FJC16G54-0																							63	1	G1 1/4	24	1	72.9	102.4	0.8			6
P-FJC16R54-0																											Rc1 1/4	24.5					

●P-RB10

Counterboring diameter ϕF , counterboring depth G

Screw diameter H, screw depth J
(For ports P, T)

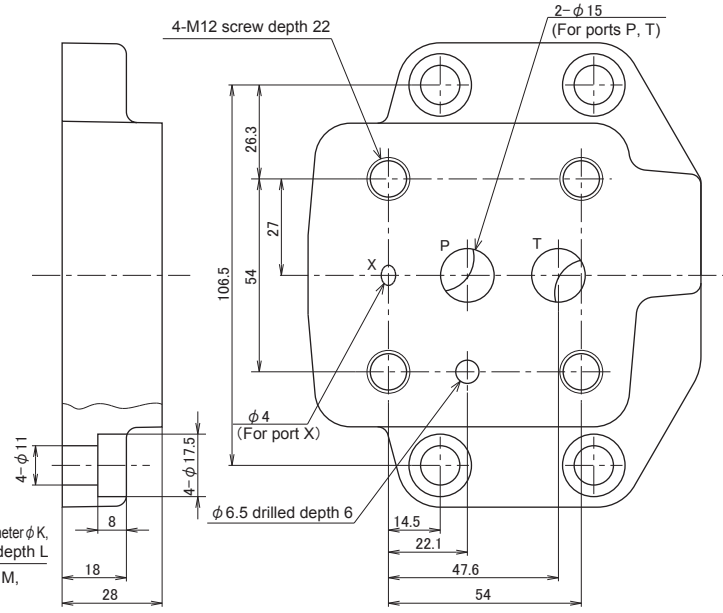
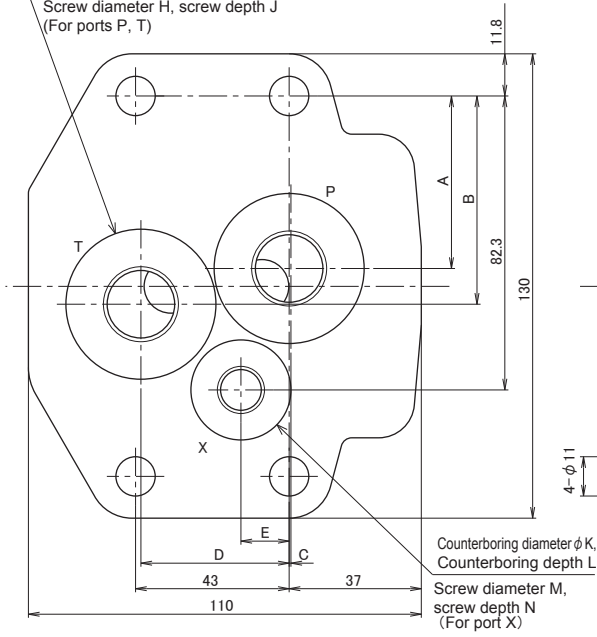

* The - mark indicates that the coupling joint center is positioned to the left of the mounting hole center.

Type	A	B	C	D	E	F	G	H	J	K	L	M	N	Mass (kg)
P-RB10G38-0						40	1	G $\frac{3}{8}$	15	28	1	G $\frac{1}{4}$	14	2.1
P-RB10R38-0	53.3	53.3	0.5	39.5	19.5	-	-	Rc $\frac{3}{8}$	16	-	-	Rc $\frac{1}{4}$	12.5	
P-RB10G12-0						42	1	G $\frac{1}{2}$	15	28	1	G $\frac{1}{4}$	14	2.1
P-RB10R12-0	48.3	58.3	0	41.5	13.5	-	-	Rc $\frac{1}{2}$	16	-	-	Rc $\frac{1}{4}$	12.5	
P-RB10G14-0						28	1	G $\frac{1}{4}$	15	28	1	G $\frac{1}{4}$	15	2.1
P-RB10R14-0	53.3	53.3	*-2	33.1	19.5	-	-	Rc $\frac{1}{4}$	12.5	-	-	Rc $\frac{1}{4}$	12.5	

●P-RB20

Counterboring diameter ϕD , counterboring depth E,
Screw diameter F, screw depth G
(For ports P, T)

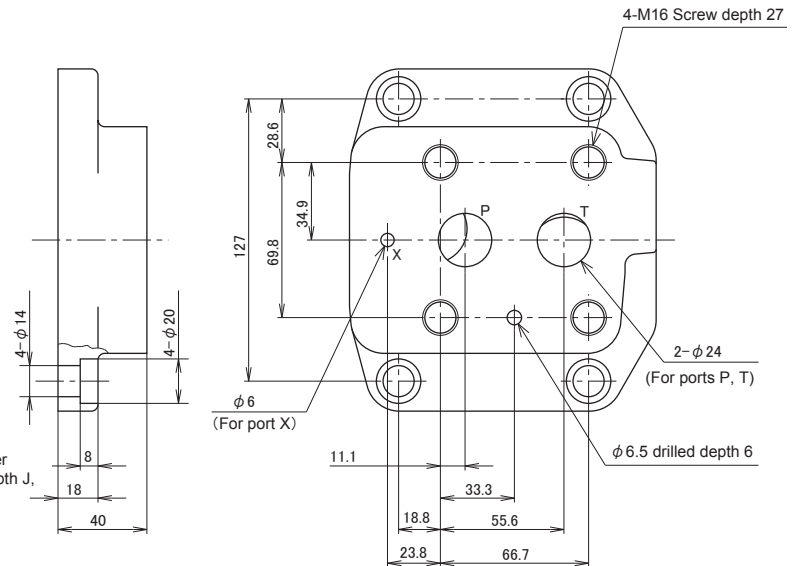
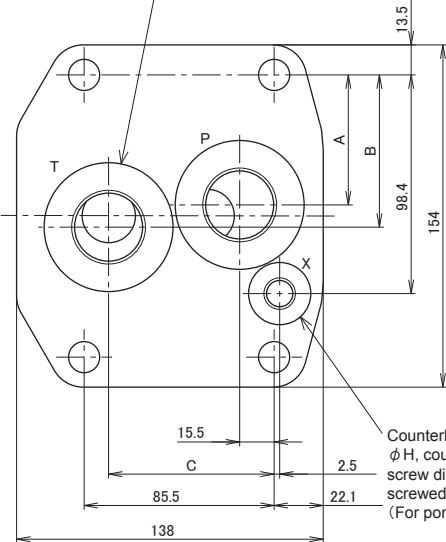

Type	A	B	C	D	E	F	G	H	J	K	L	Mass (kg)		
P-RB20G34-0						50	1	G $\frac{3}{4}$	17	28	1	G $\frac{1}{4}$	14	4.4
P-RB20R34-0	63.5	63.5	66.5	-	-	Rc $\frac{3}{4}$	18	-	-	Rc $\frac{1}{4}$	15			
P-RB20G1-0						58	1	G1	19	28	1	G $\frac{1}{4}$	14	4.4
P-RB20R1-0	58.5	68.5	74.5	-	-	Rc1	20	-	-	Rc $\frac{1}{4}$	15			

●P-RB30

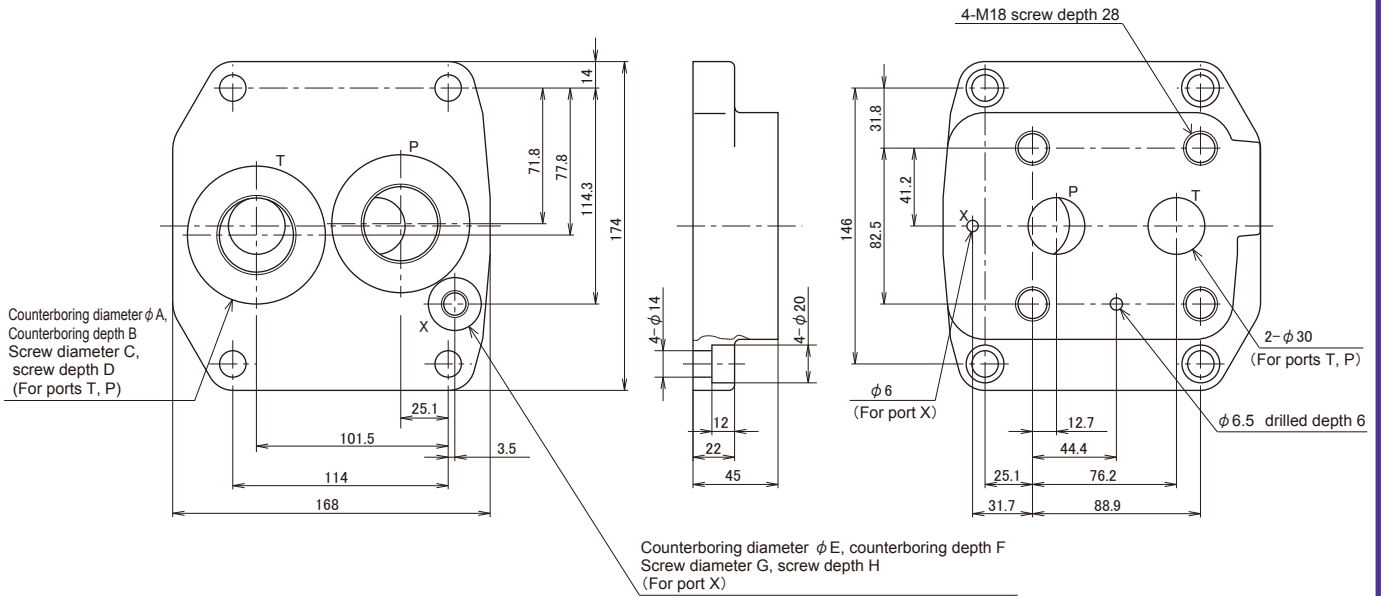

Type	A	B	C	D	E	F	G	H	Mass (kg)
P-RB30G54-0	73	1	G1 $\frac{1}{4}$	24	28	1	G $\frac{1}{4}$	14	6.9
P-RB30R54-0	-	-	Rc1 $\frac{1}{4}$	25	-	-	Rc $\frac{1}{4}$	12.5	
P-RB30G32-0	73	1	G1 $\frac{1}{2}$	24	28	1	G $\frac{1}{4}$	14	6.9
P-RB30R32-0	-	-	Rc1 $\frac{1}{2}$	25	-	-	Rc $\frac{1}{4}$	12.5	

●P-CHY10

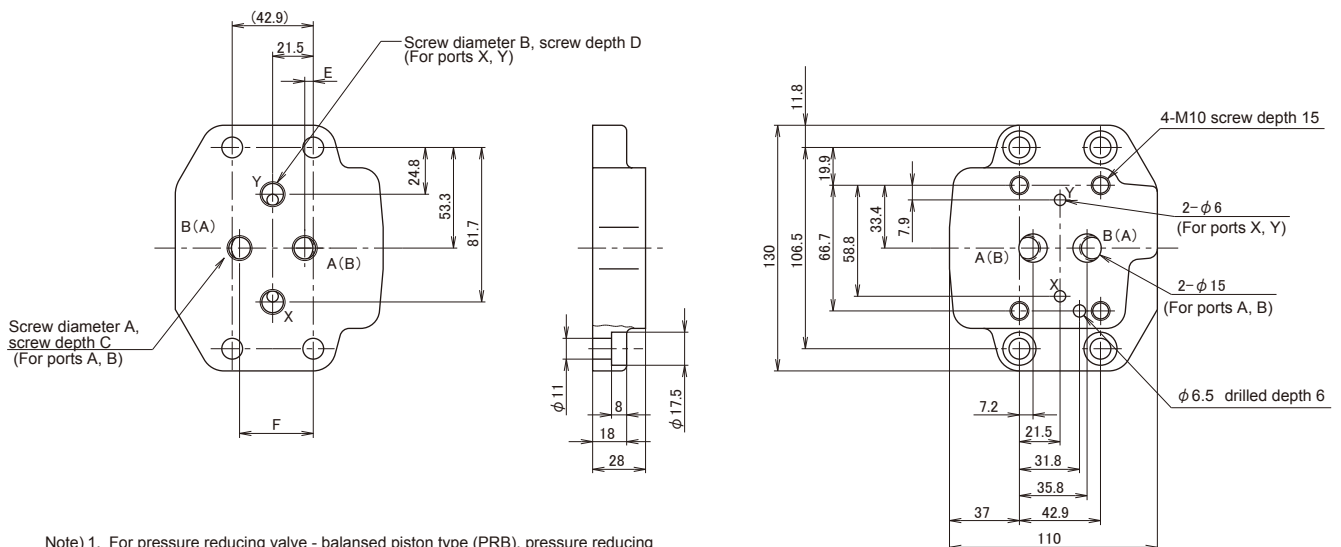

- Note 1. For pressure reducing valve - balanced piston type (PRB), pressure reducing valve - direct operated type (PRD), and solenoid proportional pressure reducing valve (PRBP), the port symbols in () apply.
2. As for pressure reducing valves and solenoid proportional pressure reducing valves, port X is not used.

Type	A	C	D	B	E	F	Mass (kg)
P-CHY10G14-0	G $\frac{1}{4}$	G $\frac{1}{4}$	15	15	4.5	39	2.1
P-CHY10R14-0	Rc $\frac{1}{4}$	Rc $\frac{1}{4}$	12.5	12.5			
P-CHY10G38-0	G $\frac{3}{8}$	G $\frac{1}{4}$	17	15	0	43.5	2.1
P-CHY10R38-0	Rc $\frac{3}{8}$	Rc $\frac{1}{4}$					
P-CHY10G12-0	G $\frac{1}{2}$	G $\frac{1}{4}$	17	15	0	43.5	2.1
P-CHY10R12-0	Rc $\frac{1}{2}$	Rc $\frac{1}{4}$					

●P-CHY20

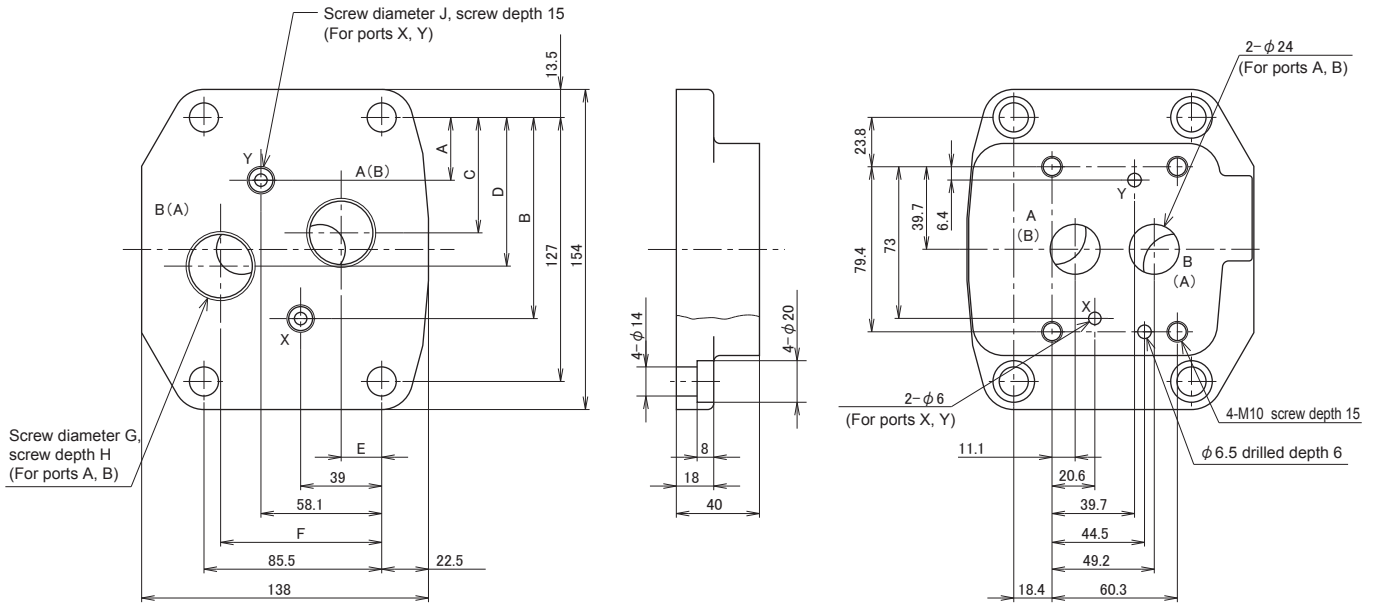

Note) 1. For pressure reducing valve - balanced piston type (PRB), and solenoid proportional pressure reducing valve (PRPB), the port symbols in () apply.

2. As for pressure reducing valves and solenoid proportional pressure reducing valves, port X is not used.

Type	A	B	C	D	E	F	G	H	J	Mass (kg)
P-CHY20G34-0	27.2	99.8	63.5	63.5	17.5	74.5	G $\frac{3}{4}$	18	G $\frac{1}{4}$	4.4
P-CHY20R34-0							Rc $\frac{3}{4}$	18	Rc $\frac{1}{4}$	
P-CHY20G1-0	30.2	96.8	55.5	71.5	19.5	77.5	G1	20	G $\frac{1}{4}$	4.4
P-CHY20R1-0							Rc1	20	Rc $\frac{1}{4}$	

●P-CHY30

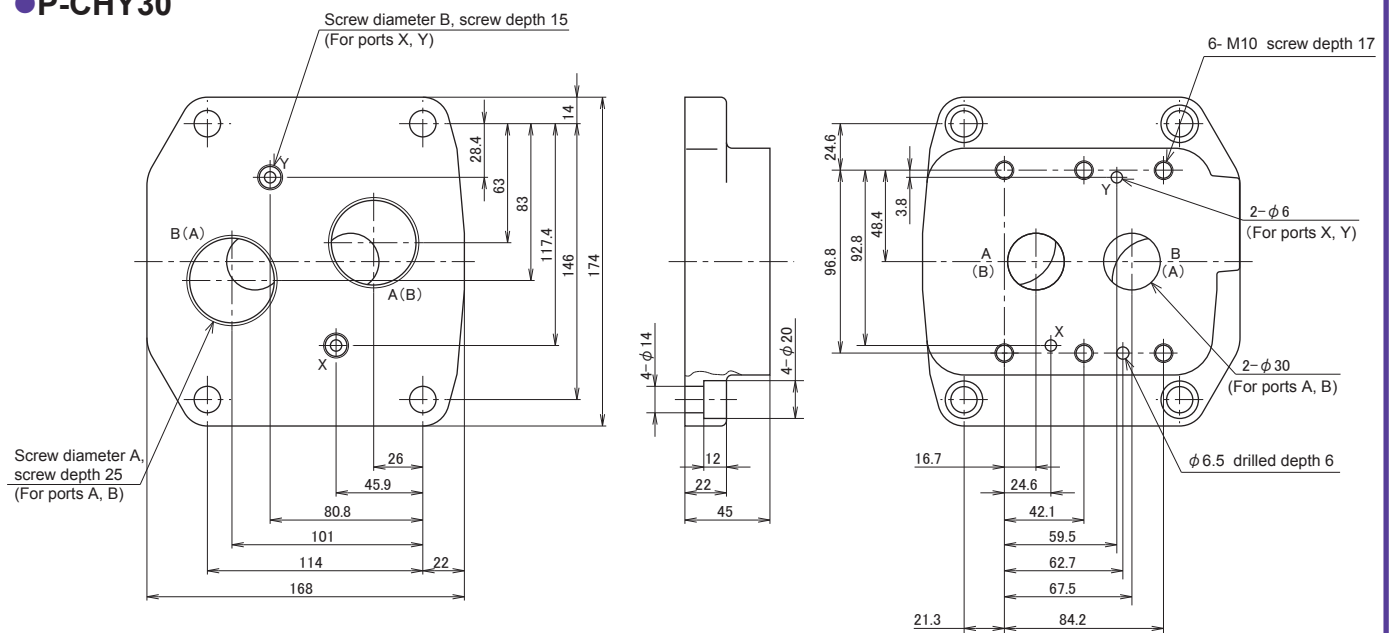

Note) 1. For pressure reducing valve - balanced piston type (PRB), and solenoid proportional pressure reducing valve (PRBP), the port symbols in () apply.

2. As for pressure reducing valves and solenoid proportional pressure reducing valves, port X is not used.

Type	A	B	Mass (kg)
P-CHY30G54-0	G1 $\frac{1}{4}$	G $\frac{1}{4}$	6.9
P-CHY30R54-0	Rc1 $\frac{1}{4}$	Rc $\frac{1}{4}$	
P-CHY30G32-0	G1 $\frac{1}{2}$	G $\frac{1}{4}$	6.9
P-CHY30R32-0	Rc1 $\frac{1}{2}$	Rc $\frac{1}{4}$	

● P-FJC5, P-F10

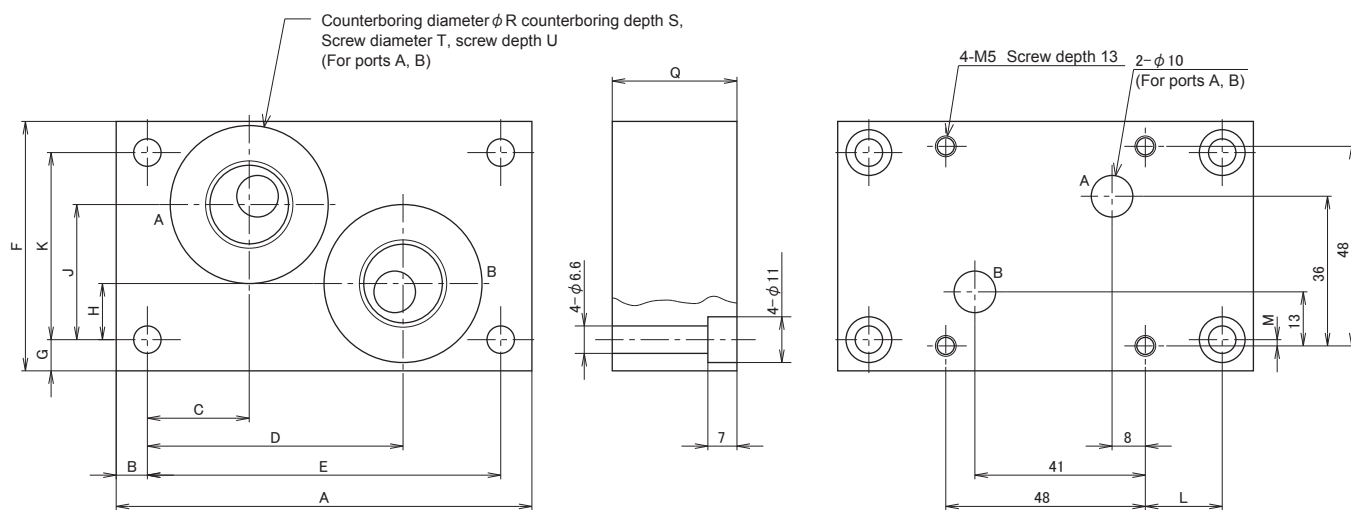

Type	A	B	C	D	E	F	G	H	J	K	L	M	Q	R	S	T	U	Mass (kg)
P-FJC5G14-0	90	7.5	21.5	54.5	75	60	7.5	11.5	34.5	45	13.5	1.5	25	—	—	$G\frac{1}{4}$	15	1.0
P-FJC5R14-0														—	—	$Rc\frac{1}{4}$	12.5	
P-F10G12-0	100	7.5	24.5	60.5	85	60	7.5	13.5	32.5	45	18.5	1.5	30	38	1	$G\frac{1}{2}$	15	1.2
P-F10R12-0														—	—	$Rc\frac{1}{2}$	17	

● P-RD6, 10, 20, 30

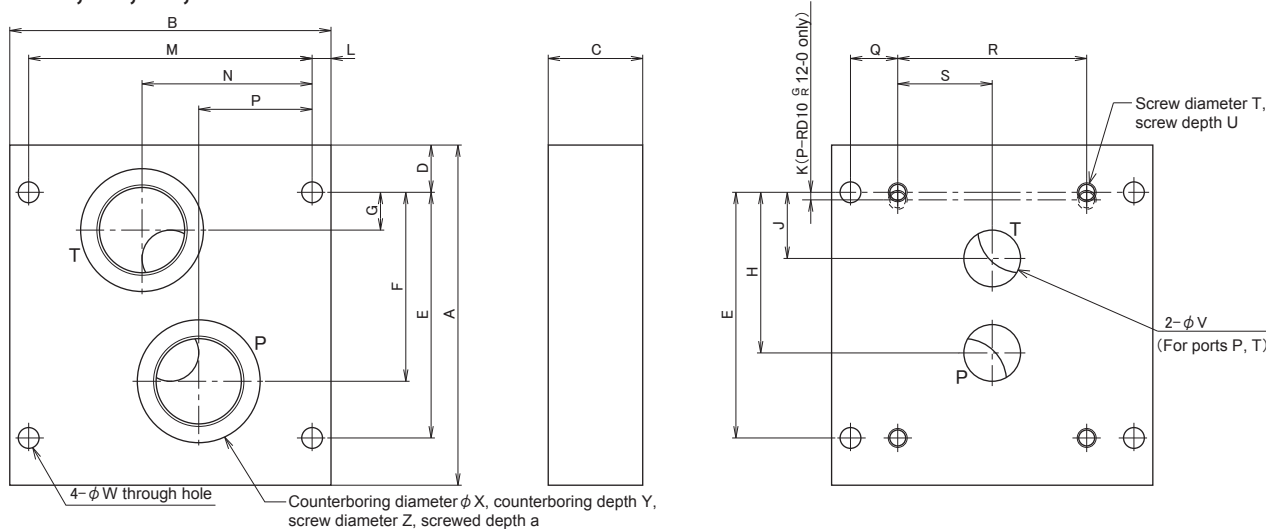

Type	A	B	C	D	E	F	G	H	J	K	L	M	N	P	Q	R	S	T	U	V	W	X	Y	Z	a	Mass (kg)
P-RD6G14-0	80	90	25	15	55	40	8	40	20	0	7.5	75	37.5	37.5	15	45	22.5	4-M6	15	6	9	—	—	$G\frac{1}{4}$	15	1.3
P-RD6R14-0																						—	—	$Rc\frac{1}{4}$	12.5	
P-RD10G12-0	100	120	35	10	80	55	12	55	31	10	10	100	50	50	20	60	30	4-M8	17	10	9	—	—	$G\frac{1}{2}$	17	3
P-RD10R12-0																						—	—	$Rc\frac{1}{2}$	17	
P-RD20G34-0	135	140	40	20	100	77	22	65	34	0	10	120	60	60	25	70	35	4-M8	18	20	11	—	—	$G\frac{3}{4}$	21	5.3
P-RD20R34-0																						—	—	$Rc\frac{3}{4}$	14	
P-RD20G1-0						—	—						G1	22												
P-RD20R1-0						—	—						Rc1	22												
P-RD30G54-0	180	170	50	25	130	100	20	85	35	0	10	150	75	75	25	100	50	4-M10	18	30	11	76	1	$G1\frac{1}{4}$	25	10.5
P-RD30R54-0																						—	—	$Rc1\frac{1}{4}$	18	
P-RD30G32-0													65	1								$G1\frac{1}{2}$	24			
P-RD30R32-0													—	—								$Rc1\frac{1}{2}$	18			

● P-DE10

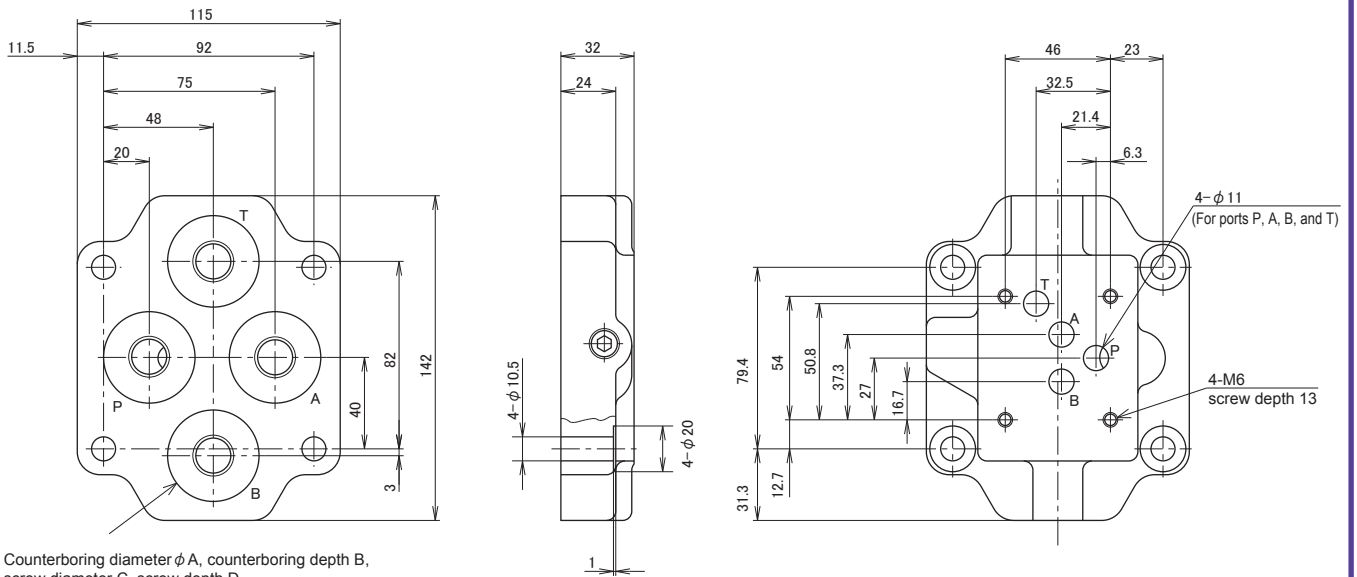

Counterboring diameter ϕ A, counterboring depth B, screw diameter C, screw depth D (For ports P, A, B, and T)

Type	A	B	C	D	Mass (kg)
P-DE10G38-0	40	1	G $\frac{3}{8}$	15	2.7
P-DE10R38-0	—	—	Rc $\frac{3}{8}$	16	
P-DE10G12-0	42	1	G $\frac{1}{2}$	15	2.7
P-DE10R12-0	—	—	Rc $\frac{1}{2}$	16	

● P-DEH22

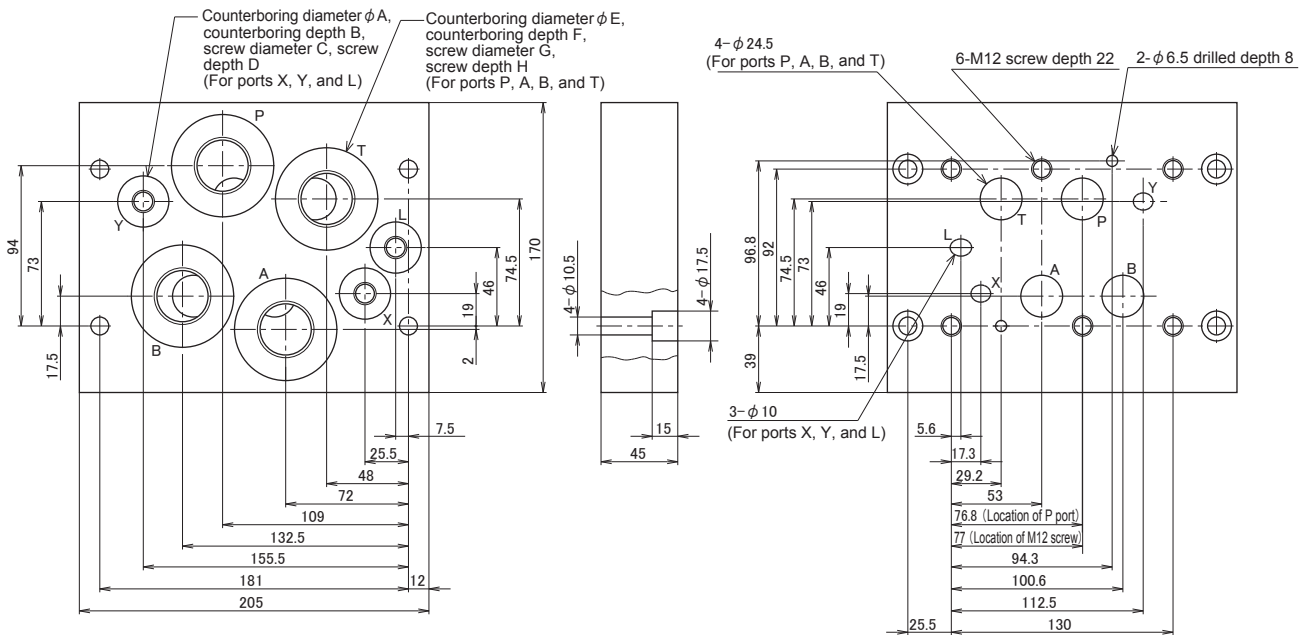

Type	A	B	C	D	E	F	G	H	Mass (kg)
P-DEH22G1-0	30	1	G $\frac{1}{4}$	14	60	1	G1	19	11
P-DEH22R1-0	—	—	Rc $\frac{1}{4}$	15	—	—	Rc1	20	

● P-DEH22

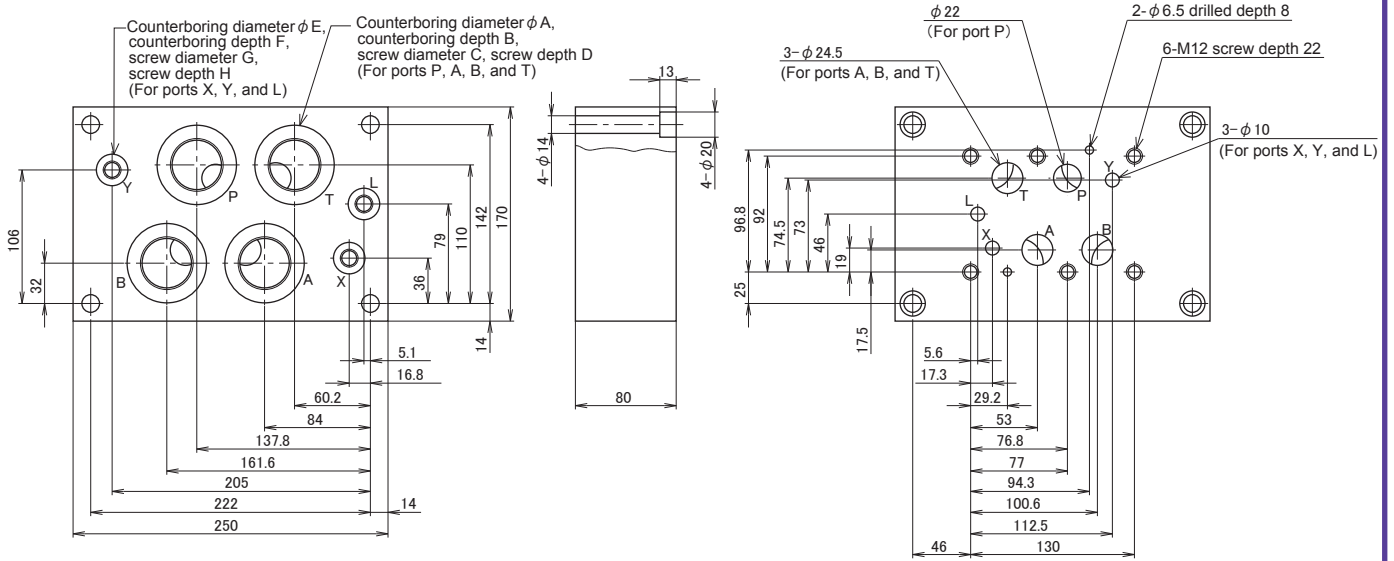

Type	A	B	C	D	E	F	G	H	Mass (kg)
P-DEH22G54-0	63	1	G1 $\frac{1}{4}$	25	25	1	G $\frac{1}{4}$	14	24
P-DEH22R54-0	—	—	Rc1 $\frac{1}{4}$	24.5	—	—	Rc $\frac{1}{4}$	12.5	
P-DEH22G32-0	65	1	G1 $\frac{1}{2}$	25	25	1	G $\frac{1}{4}$	14	24
P-DEH22R32-0	—	—	Rc1 $\frac{1}{2}$	24.5	—	—	Rc $\frac{1}{4}$	12.5	

● P-DEH32

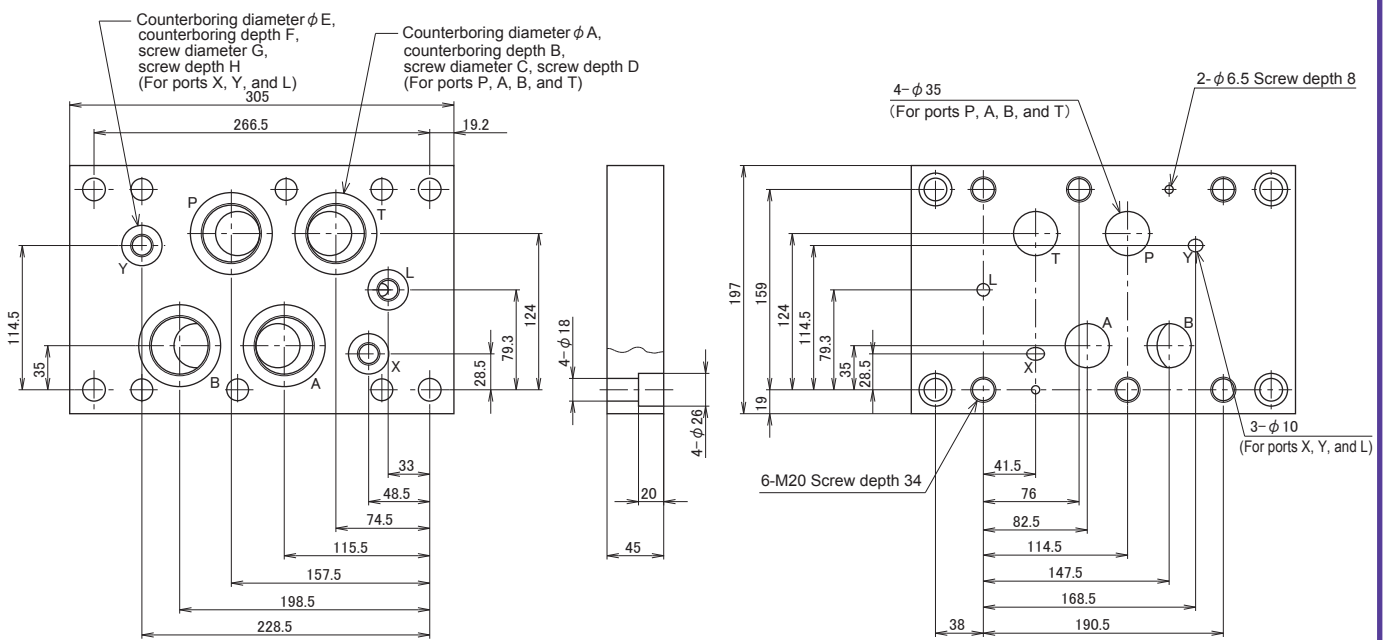

Type	A	B	C	D	E	F	G	H	Mass (kg)
P-DEH32G32-0	65	1	G1 $\frac{1}{2}$	25	32	1	G $\frac{3}{8}$	15	19
P-DEH32R32-0	—	—	Rc1 $\frac{1}{2}$	24.5	—	—	Rc $\frac{3}{8}$	14	

● P-DEH16

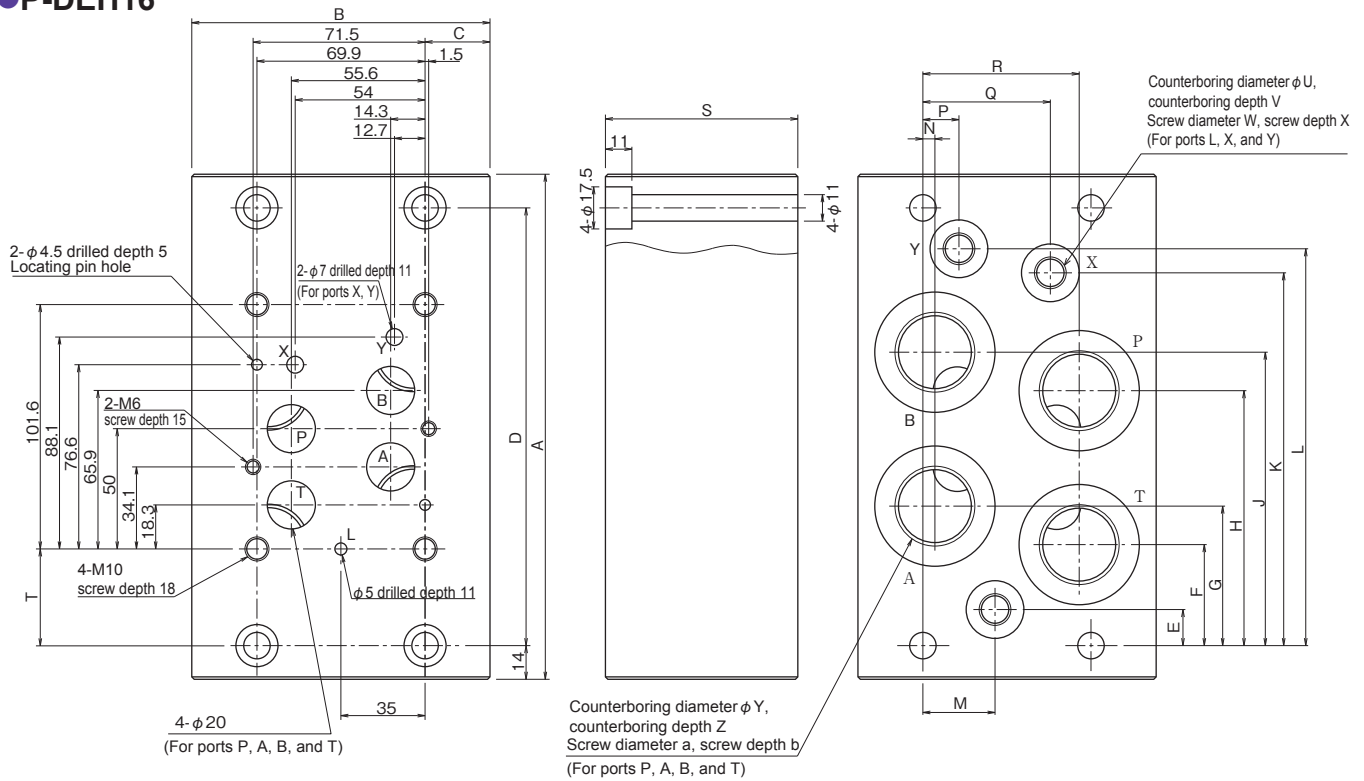

Type	A	B	C	D	E	F	G	H	J	K	L	M	N	P	Q	R	S	T	U	V	W	X	Y	Z	a	b	Mass (kg)
P-DEH16G34-0	188	104	17	160	17	37	53	90	106	129	144	27	10	19	54	60	60	29	$\phi 25$	0.3 or less	G $\frac{1}{4}$	15	$\phi 45$	0.3 or less	G $\frac{3}{4}$	21	8.5
P-DEH16R34-0																					Rc $\frac{1}{4}$	12.5	-	-	Rc $\frac{3}{4}$	19	
P-DEH16G1-0	210	124	27	182	15	42	58	106	122	155	165	30	5	15	53	65	80	40	$\phi 25$	0.3 or less	G $\frac{1}{4}$	15	$\phi 52$	0.3 or less	G1	25	14.5
P-DEH16R1-0																					Rc $\frac{1}{4}$	12.5	-	-	Rc1	22	

● P-DE6

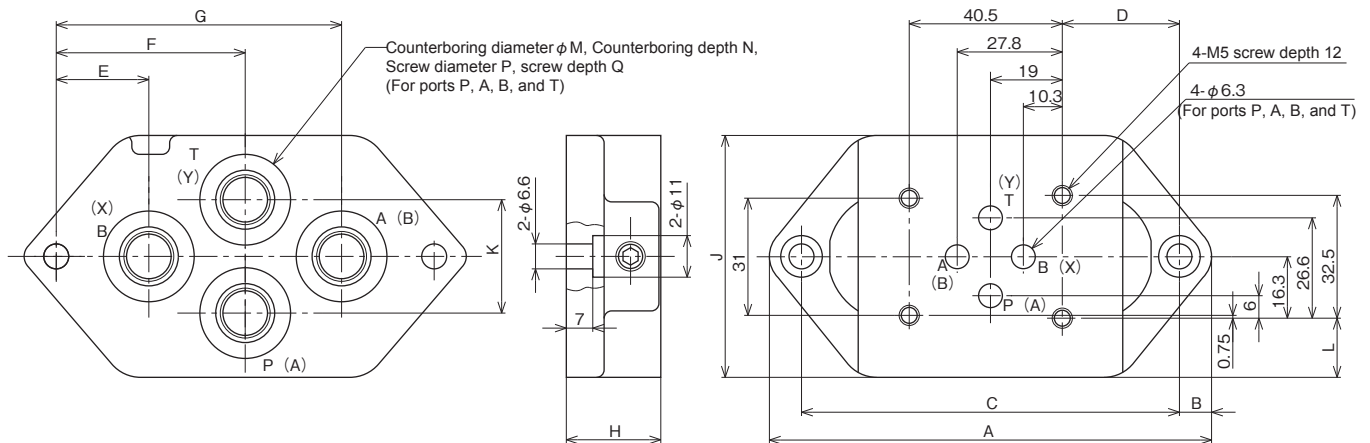

Note) 1. For sequence valve - direct operated type (SD), and pressure reducing valve - direct operated type (PRD), the port symbols in () apply.

2. As for pressure reducing valve - direct operated type (PRD), port X is not used.

Type	A	B	C	D	E	F	G	H	J	K	L	M	N	P	Q	Mass (kg)
P-DE6G14-0	117	8.5	100	31	24.5	50	75.5	25	64	30	15.7	25	1	G $\frac{1}{4}$	14	1.0
P-DE6R14-0														Rc $\frac{1}{4}$	12.5	
P-DE6G38-0	155	12.5	130	46	31	65	99	30	84	40	25.7	32	1	G $\frac{3}{8}$	17	2.2
P-DE6R38-0														Rc $\frac{3}{8}$	14	

● P-FK16, P-FK10

Counterboring diameter ϕh
Counterboring depth i
Screw diameter j
Screw depth k
(For ports A, B, and T)

Counterboring diameter ϕm , counterboring depth n ,
Screw diameter q , screw depth r
(For port X)
(It is not provided for sub-plate type P-FK16.)

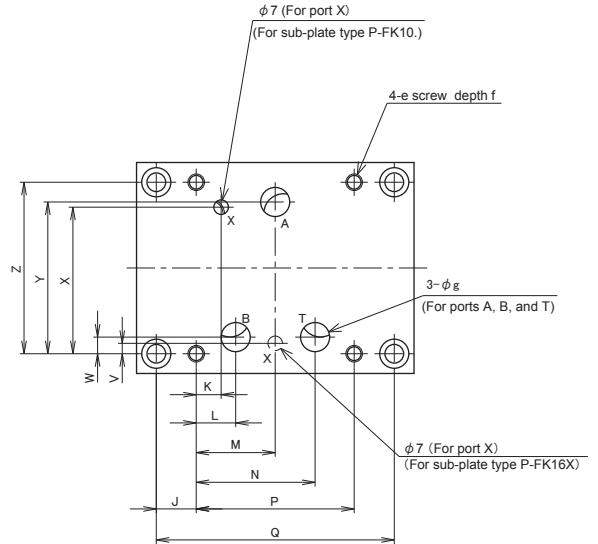
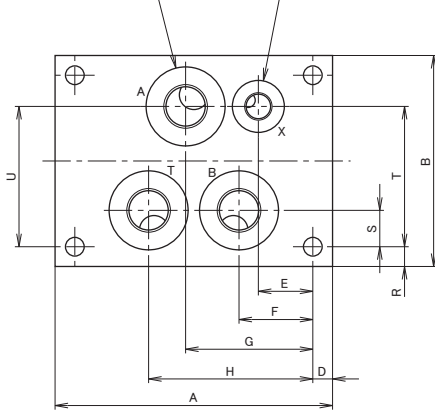

Type	A	B	C	D	E	F	G	H	J	K	L	M	N	P	Q	R	S	T	U	V	W	X	Y	Z	a	b
P-FK10G12-0	133.5	101.5	30	9.5	26.2	35.5	61.2	79	19.2	12	19	38	57.2	76	114.5	9.5	17.5	67.5	67.5	—	8	70.5	73	82.5	9	9
P-FK10R12-0																										
P-FK16G1-0					—					—																
P-FK16R1-0	168	123.5	50	11		44	73	102	22.3		23.8	50.8	77.8	101.5	146	11	21		80.5		12.7		89	101.5	11	11
P-FK16XG1-0					32																					
P-FK16XR1-0																										
Type	d	e	f	g	h	i	j	k	m	n	q	r	Mass (kg)													
P-FK10G12-0	14	M8	13	14	38	1	G $\frac{1}{2}$	15	25	1	G $\frac{1}{4}$	14	2.8													
P-FK10R12-0					—	—	Rc $\frac{1}{2}$	17	—	—	Rc $\frac{1}{4}$	12.5														
P-FK16G1-0					52	1	G1	20	25	1	G $\frac{1}{4}$	14	7.3													
P-FK16R1-0					—	—	Rc1	22	—	—	Rc $\frac{1}{4}$	12.5														
P-FK16XG1-0	17.5	M10	21	20	—	—	G1	20	—	—	G $\frac{1}{4}$	15														
P-FK16XR1-0					—	—	Rc1	22	—	—	Rc $\frac{1}{4}$	12.5														

● P-PU10

Counterboring diameter ϕD , counterboring depth E ,
Screw diameter F , screw depth G (For ports A, P, and T)

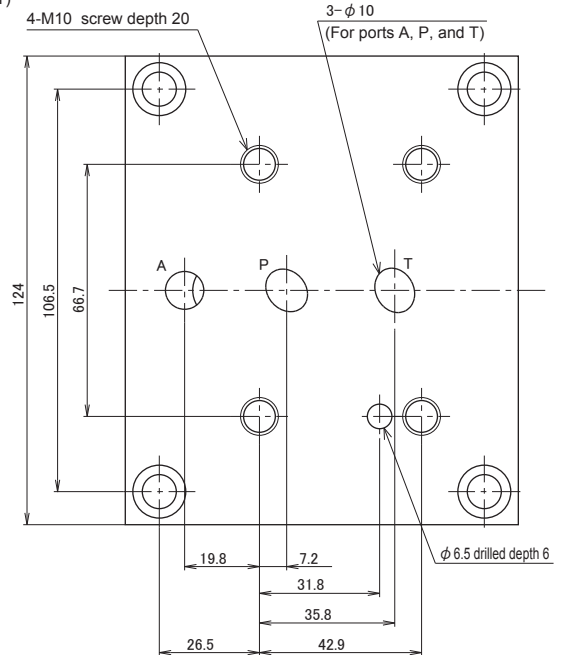
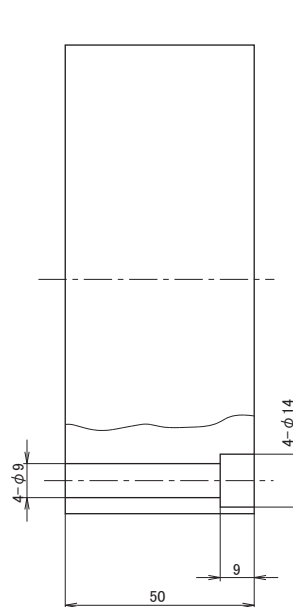
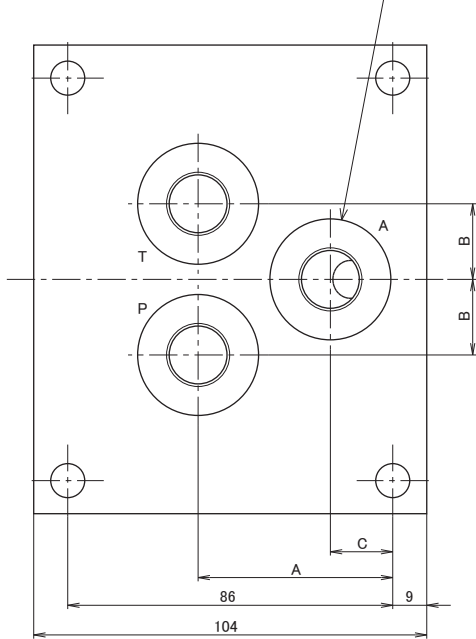

Type	A	B	C	D	E	F	G	Mass (kg)
P-PU10G38-0	51.5	20	16.5	32	1	G $\frac{3}{8}$	15	4.5
P-PU10R38-0				—	—	Rc $\frac{3}{8}$	14	
P-PU10G12-0	49.5	22	13.5	38	1	G $\frac{1}{2}$	15	4.5
P-PU10R12-0				—	—	Rc $\frac{1}{2}$	17	

● P-PU20

Counterboring diameter ϕC , counterboring depth D,
Screw diameter E, screw depth F
(For ports A, P, and T)

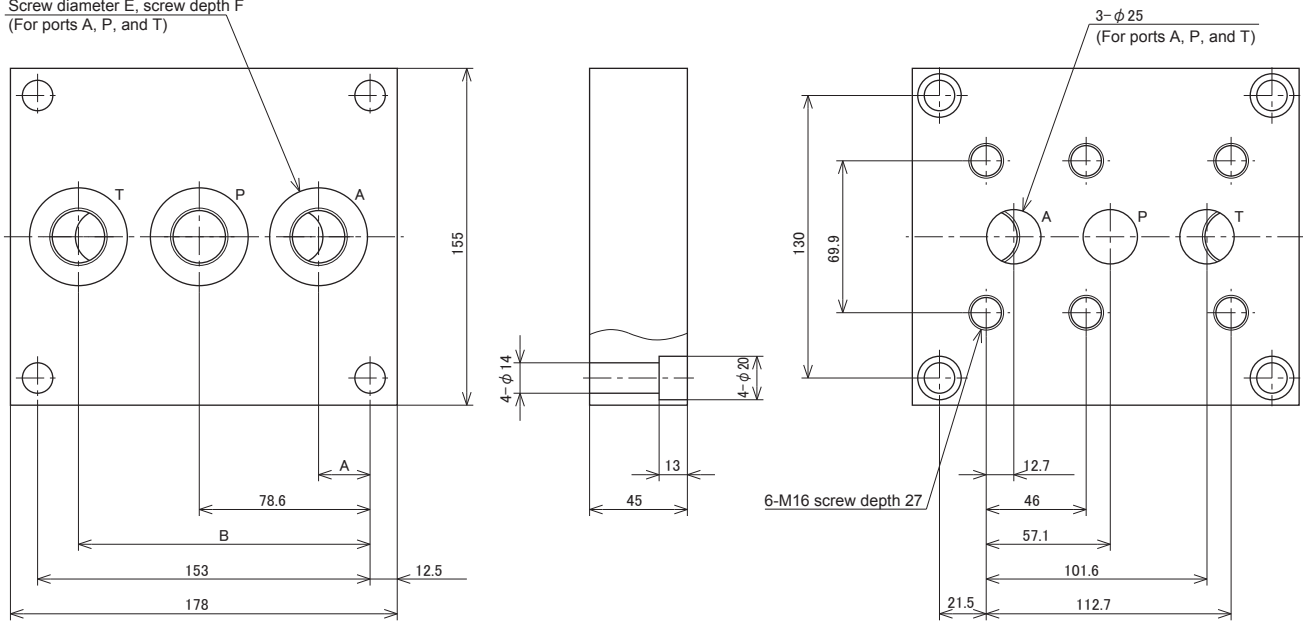

Type	A	B	C	D	E	F	Mass (kg)
P-PU20G34-0	23.7	134.2	45	0.5 or less	G $\frac{3}{4}$	18	9
P-PU20R34-0			—	—	Rc $\frac{3}{4}$	19	
P-PU20G1-0	20.5	136.5	52	0.5 or less	G1	20	9
P-PU20R1-0			—	—	Rc1	22	

● P-PU30

Counterboring diameter ϕA , counterboring depth B,
screw diameter C, screw depth D
(For ports A, P, and T)

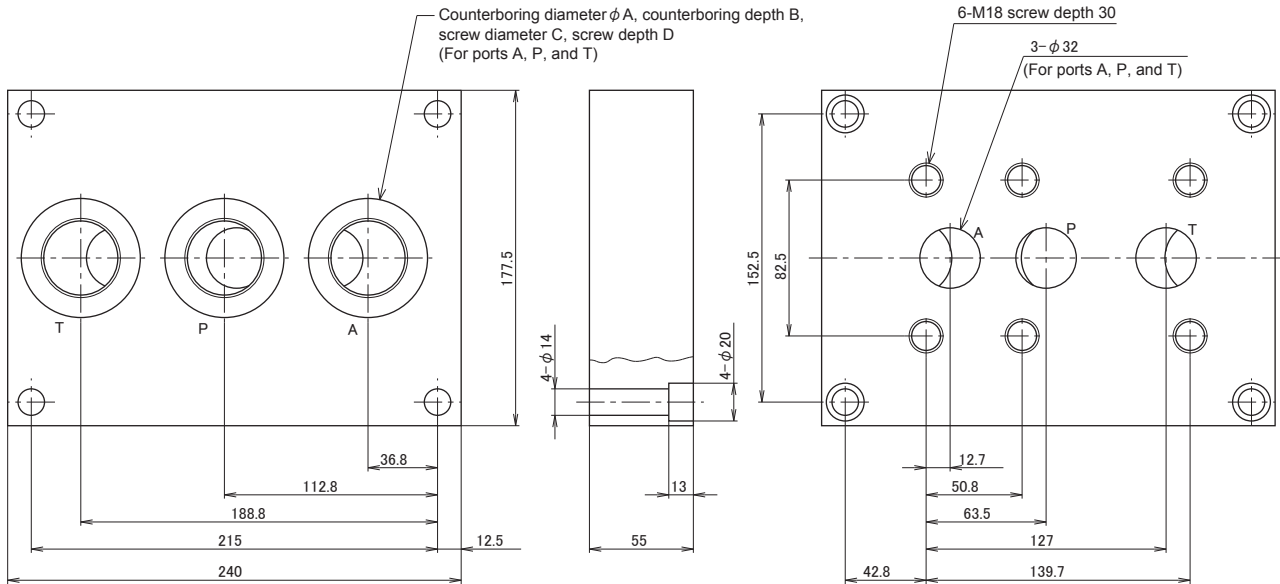

Type	A	B	C	D	Mass (kg)
P-PU30G54-0	63	1	G1 $\frac{1}{4}$	24	21
P-PU30R54-0	—	—	Rc1 $\frac{1}{4}$	24.5	
P-PU30G32-0	65	1	G1 $\frac{1}{2}$	24	21
P-PU30R32-0	—	—	Rc1 $\frac{1}{2}$	25.5	

● P-RDPV5 $\frac{G}{R}$ 14-0

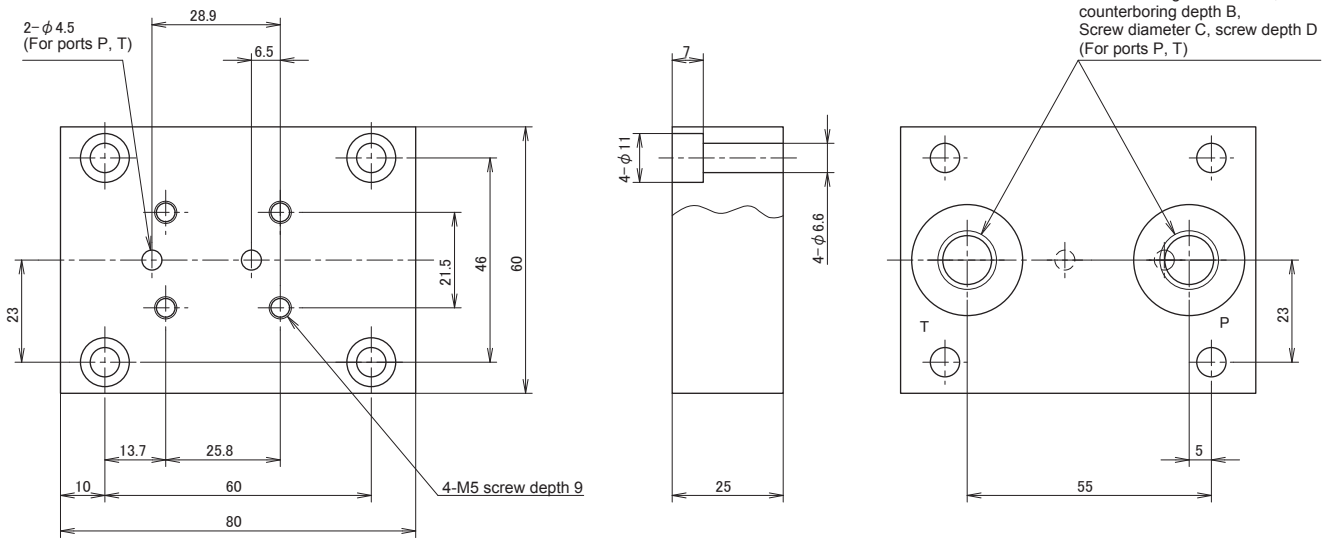

Type	A	B	C	D
P-RDPV5G14-0	25	1	G $\frac{1}{4}$	15
P-RDPV5R14-0	—	—	Rc $\frac{1}{4}$	12.5

Sub-plate

Flange·Nipple

● **TFA_B^A**-Low pressure 20.6 MPa (210 kgf/cm²) flange

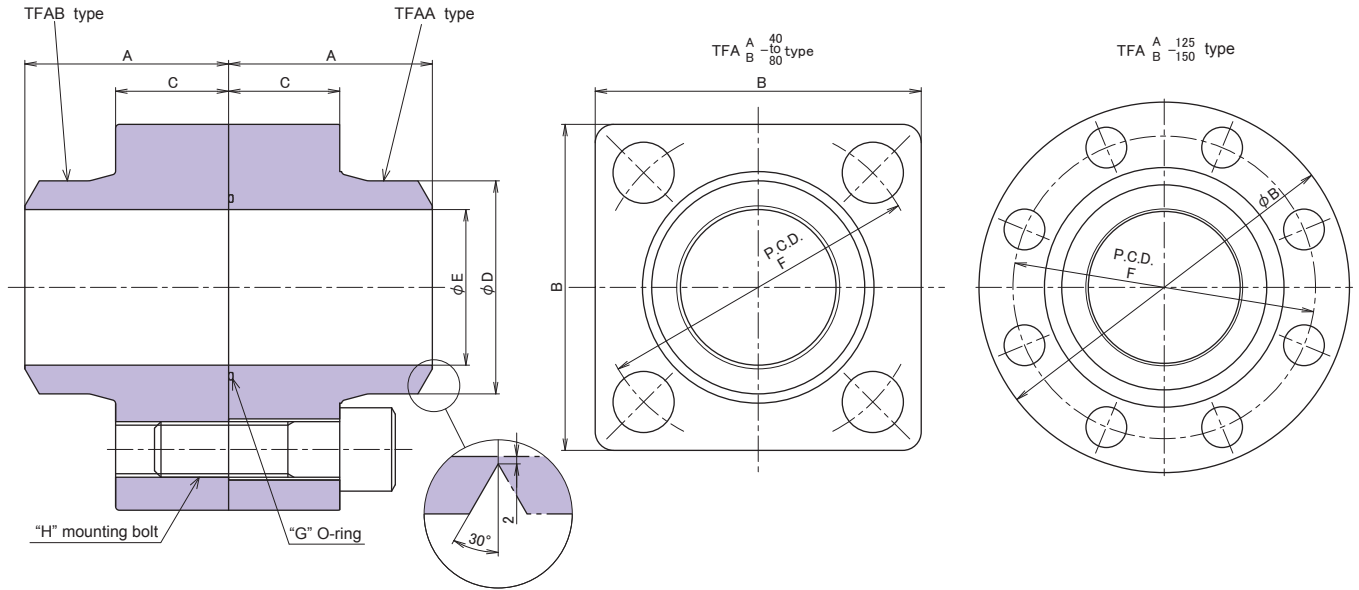

Type	Flange dimension (mm)						Mass (kg)	"G" O-ring dimension	"H" mounting bolt dimension	Reference: Applicable pipe (mm)	
	A	B	C	D	E	F				Outer diameter	Thickness
TFAA-40	65	98	35	61	43	98	2.6	JIS B2401 G55 Hs90	4-M16-55	60.5	7.8
TFAB-40							2.6				
TFAA-50	70	116	40	77	57	118	3.9	JIS B2401 G65 Hs90	4-M20-65	76.3	9.5
TFAB-50							3.9				
TFAA-63	90	146	50	90	67	145	7.9	JIS B2401 G75 Hs90	4-M24-80	89.1	11.1
TFAB-63							7.9				
TFAA-80	110	176	60	115	84	175	13	JIS B2401 G95 Hs90	4-M30-100	114.3	15.0
TFAB-80							13				
TFAA-125	150	300	80	166	123	245	42	JIS B2401 G135 Hs90	8-M30-120	165.2	21.0
TFAB-125							42				
TFAA-150	170	360	90	217	162	290	70	JIS B2401 G175 Hs90	8-M36-140	216.3	27.0
TFAB-150							70				

● **TFX_B^A**-High pressure 30.9 MPa (315 kgf/cm²) flange

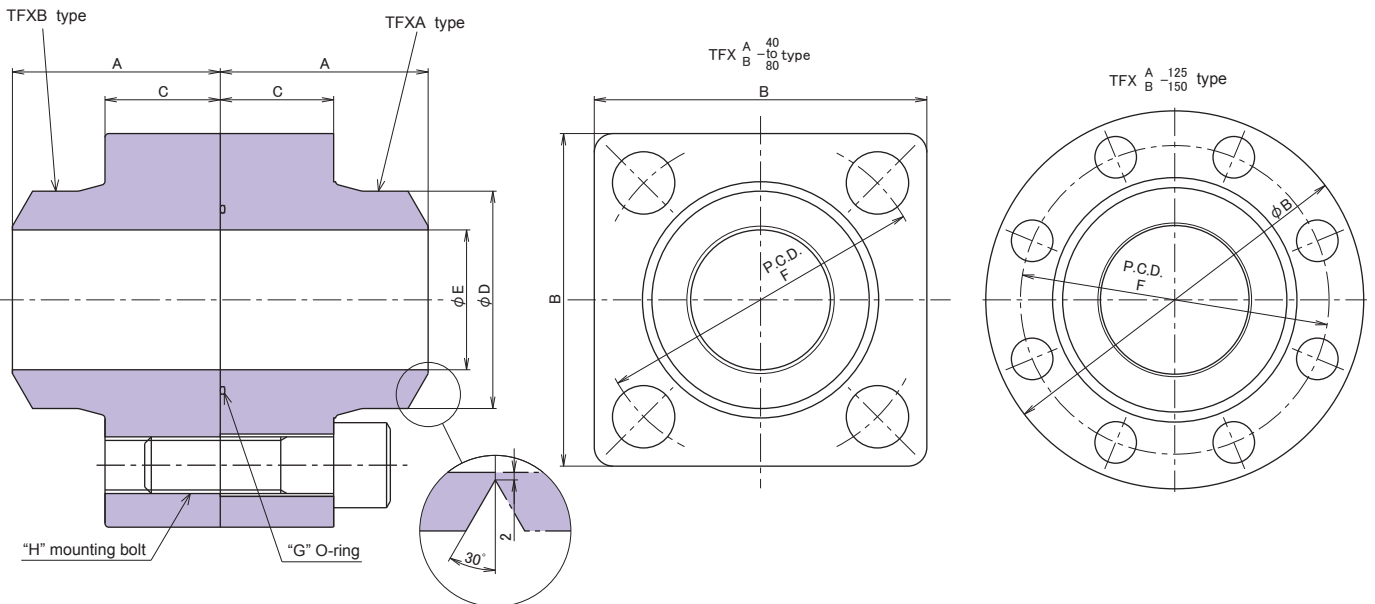

Type	Flange dimension (mm)						Mass (kg)	"G" O-ring dimension	"H" mounting bolt dimension	Reference: Applicable pipe (mm)	
	A	B	C	D	E	F				Outer diameter	Thickness
TFXA-40	65	98	35	61	39	98	2.7	JIS B2401 G55 Hs90	4-M16-55	60.5	10.5
TFXB-40							2.7				
TFXA-50	70	116	40	77	50	118	4.5	JIS B2401 G65 Hs90	4-M20-65	76.3	13.0
TFXB-50							4.5				
TFXA-63	90	146	50	90	58	145	8.5	JIS B2401 G75 Hs90	4-M24-80	89.1	15.2
TFXB-63							8.5				
TFXA-80	110	176	60	115	74	175	14	JIS B2401 G95 Hs90	4-M30-100	114.3	20.0
TFXB-80							14				
TFXA-125	150	300	80	166	118	245	45	JIS B2401 G135 Hs90	8-M30-120	165.2	30.0
TFXB-125							45				
TFXA-150	170	360	90	217	146	290	75	JIS B2401 G175 Hs90	8-M36-140	216.3	35.0
TFXB-150							75				

Flange • Nipple

●STNL-High pressure 30.9 MPa (315 kgf/cm²) screw nipple

- Maximum working pressure 30.9 MPa (315 kgf/cm²)
- In case of using in a place where impact pressure or vibration may occur, countermeasure such as pipe support or rubber hose shall be provided.

- Designate the type of screw nipple in the following way.
 - In case the O-ring is not needed: STNL*S
 - In case the O-ring (Nitrile rubber) is equipped: STNL*S
 - In case the O-ring (Fluorine rubber) is equipped: STNL*V

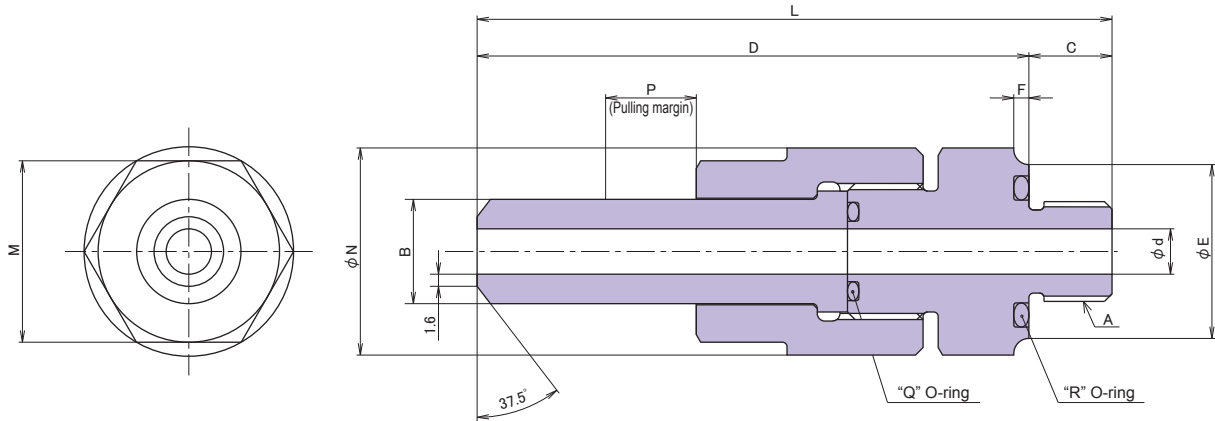

Type	d	A	B	C	D	E	F	L	M	N	P	"Q" O-ring dimension	"R" O-ring dimension	Mass (kg)
STNL- $\frac{1}{4}$	6	G $\frac{1}{4}$	13.8	11	73	23	2	84	24	27	12	JISB2401 P10 Hs90	JISB2401 P16 Hs90	0.21
STNL- $\frac{3}{8}$	9	G $\frac{3}{8}$	17.3	12	80	30	2	92	32	37	14	JISB2401 P14 Hs90	JISB2401 P20 Hs90	0.43
STNL- $\frac{1}{2}$	12	G $\frac{1}{2}$	21.7	12	89	35	2	101	36	41	15	JISB2401 P16 Hs90	JISB2401 G25 Hs90	0.55
STNL- $\frac{3}{4}$	15	G $\frac{3}{4}$	27.2	15	102	41	2.5	117	41	47	17	JISB2401 P22 Hs90	JISB2401 G30 Hs90	0.85
STNL-1	22	G1	34	17	122	48	2.5	139	50	57	20	JISB2401 G30 Hs90	JISB2401 P36 Hs90	1.42
STNL-1 $\frac{1}{4}$	29	G1 $\frac{1}{4}$	42.7	22	140	60	3	162	65	75	25	JISB2401 G40 Hs90	JISB2401 G45 Hs90	2.93
STNL-1 $\frac{1}{2}$	32	G1 $\frac{1}{2}$	48.6	22	141	63	3	163	65	75	25	JISB2401 G40 Hs90	JISB2401 G50 Hs90	3.00

●HTN-Low pressure 20.6 MPa (210 kgf/cm²) screw nipple

- Maximum working pressure 20.6 MPa (210 kgf/cm²)
- In case of using in a place where impact pressure or vibration may occur, countermeasure such as pipe support or rubber hose shall be provided.

- Designate the type of screw nipple in the following way.
 - In case the O-ring is not needed: HTN*
 - In case the O-ring (Nitrile rubber) is equipped: HTN*S
 - In case the O-ring (Fluorine rubber) is equipped: HTN*V

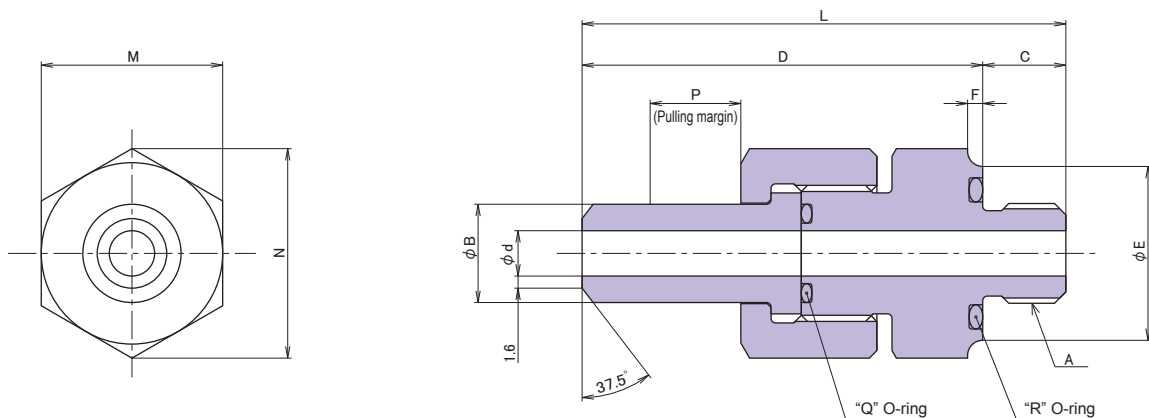

Type	d	A	B	C	D	E	F	L	M	N	P	"Q" O-ring dimension	"R" O-ring dimension	Mass (kg)
HTN- $\frac{1}{4}$	6	G $\frac{1}{4}$	13	11	53	23	2	64	24	27.7	12	JISB2401 P10 Hs90	JISB2401 P16 Hs90	0.14
HTN- $\frac{3}{8}$	9	G $\frac{3}{8}$	17	12	60	30	2	72	32	37	14	JISB2401 P14 Hs90	JISB2401 P20 Hs90	0.26
HTN- $\frac{1}{2}$	12	G $\frac{1}{2}$	20	12	63	35	2	75	36	41.6	15	JISB2401 P16 Hs90	JISB2401 G25 Hs90	0.33
HTN- $\frac{3}{4}$	15	G $\frac{3}{4}$	26	15	74	41	2.5	89	41	47.3	18	JISB2401 P22 Hs90	JISB2401 G30 Hs90	0.55
HTN-1	22	G1	34	17	84	48	2.5	101	50	57.7	21	JISB2401 G30 Hs90	JISB2401 P36 Hs90	0.90
HTN-1 $\frac{1}{4}$	29	G1 $\frac{1}{4}$	42	22	92	60	3	114	65	75	27	JISB2401 G40 Hs90	JISB2401 G45 Hs90	1.64
HTN-1 $\frac{1}{2}$	32	G1 $\frac{1}{2}$	47	22	97	63	3	119	65	75	27	JISB2401 G40 Hs90	JISB2401 G50 Hs90	1.72
HTN-2	42	G2	60	25	108	77	3	133	80	92.4	28	JISB2401 G50 Hs90	JISB2401 G65 Hs90	3.00

Other general purpose valves

SUN cartridge valve

Features of SUN cartridge valve

- SUN cartridge valves adopt two piece structure called “floating style”.
The body which has valve mounting threads and the sleeve which contains internal operating part are coupled with certain freedom, and the sleeve is, keeping slight gap in the axis direction between the locating shoulder and bottom shoulder, mounted in the cartridge hole (See the following figure). Hence, the tightening distortion due to cartridge mounting does not affect the internal operation part, which realises the stable operation.
- It smoothly operates at high pressure such as maximum working pressure 34.3 MPa, and leakage amount is very slight.
- Because four serieses each of which has different maximum flow rate are prepared for most of the cartridges, the best suited valve for your system will be found.

- (1) This part guides the cartridge hole to maintain the concentricity of cartridge valve and cartridge hole.
- (2) Having a slight gap between the cartridge hole and tip of the cartridge valve, the body which has cartridge valve mounting threads and the sleeve which contains internal operating part are coupled with certain freedom. (Floating style)
- (3) The floating style structure enables to tighten at high torque.
As the result, the reliability has significantly increased against loosening or oil leakage.
- (4) This face called locating shoulder supports the axial force due to tightening, to prevent distortion on the sleeve portion.
- (5) Locating the thread portion at immediate proximity of the sleeve keeps the eccentricity of sleeve to minimum.
- (6) This face called bottom shoulder receives all the load that occurs during operation. (The load is not shared to the wire ring.)
- (7) Cartridge valves with various functions can be applied to the same cartridge hole, which provides flexibility in designing.

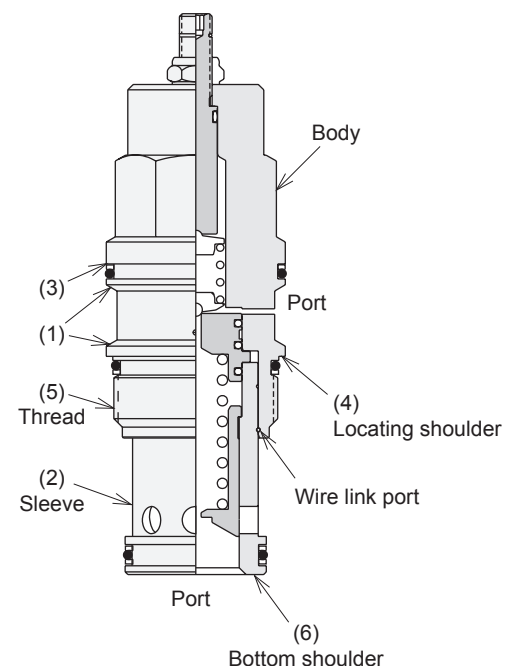

* As for the details, please see the catalogue of SUN cartridge valves.

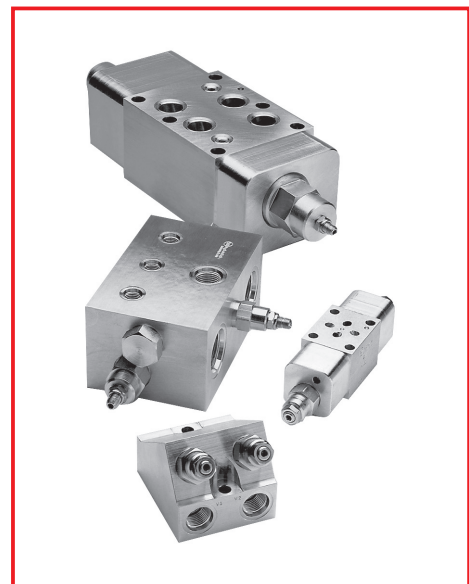

Application examples of SUN cartridge valves

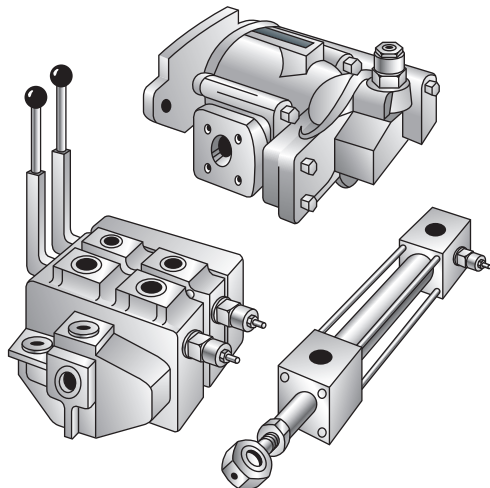

Built-in cartridge type

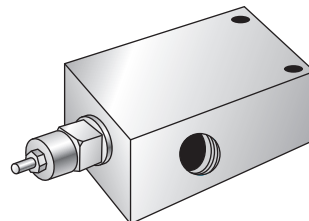

Standard thread connection casing with built-in cartridge

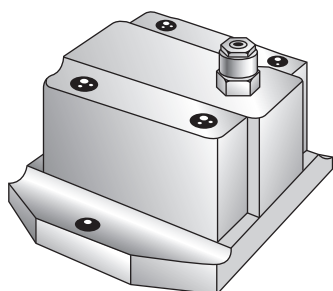

Conventional model replacement model

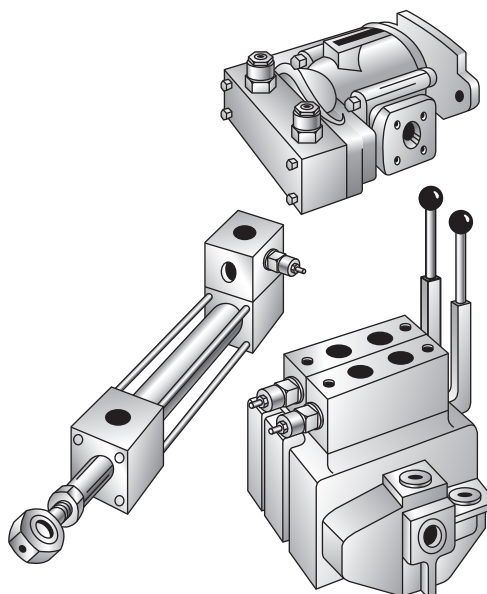

Direct mounting block

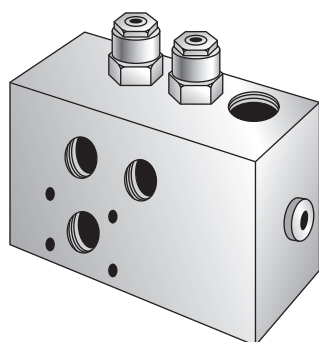

Usage-application type valve block

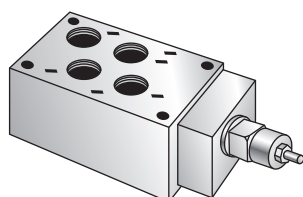

Sandwich valve

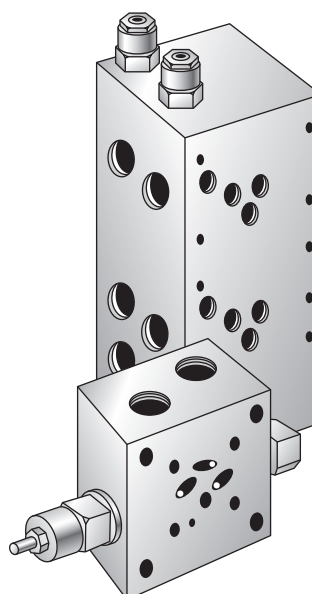

Sub-plate with cartridge valve

Kawasaki Heavy Industries, Ltd. Sales and service network

KAWASAKI HEAVY INDUSTRIES, LTD. PRECISION MACHINERY COMPANY

Tokyo Head Office

14-5 Kaigan 1-chome, Minato-ku, Tokyo 105-8315,
Japan

Phone: 81-03-3435-6862 Fax: 81-03-3435-2023

Kobe Head Office

Kobe Crystal Tower, 1-3 Higashikawasaki-cho 1-chome, Chuo-ku, Kobe 650-8680, Japan

Phone: 81-078-360-8605 Fax: 81-078-360-8609

Nishi-Kobe Works

234 Matsumoto, Hasetani-cho, Nishi-ku, Kobe 651-2239, Japan

Phone: 81-078-991-1133 Fax: 81-078-991-3186

Kyushu Branch

Hakata Ekimae Daiichi Seimei Bldg. 9F, 1-4-1 Hakata Ekimae, Hakata-ku, Fukuoka,
812-0011, Japan

Phone: 81-092-432-9561 Fax: 81-092-432-9566

Tokyo Service Center

4-9-2 Onitaka, Ichikawa-shi, Chiba, 272-0015, Japan

Phone: 81-047-379-8181 Fax: 81-047-379-8186

Imabari Service Center

c/o Kawasaki Trading Co., Ltd., Gibraltar Seimei Bldg. 1-5-3 Kita Horai-cho, Imabari-shi,
Ehime, 794-0028, Japan

Phone: 81-0898-22-2531 Fax: 81-0898-22-2183

Fukuoka Service Center

2-10-17 Shimonofu, Shingumachi, Kasuya-gun, Fukuoka, 811-0112, Japan

Phone: 81-092-963-0452 Fax: 81-092-963-2755

<http://www.khi.co.jp/kpm/>

OVERSEAS SUBSIDIARIES

Kawasaki Precision Machinery (UK) Ltd.

Ernesettle Lane, ernesettle, Plymouth, Devon PL5 2SA, United Kingdom

Phone: 44-1752-364394 Fax: 44-1752-364816

<http://www.kpm-eu.com>

Kawasaki Precision Machinery (U.S.A.), Inc.

3838 Broadmoor Avenue SE, Grand Rapids, Michigan 49512 U.S.A.

Phone: 1-616-975-3100 Fax: 1-616-975-3103

<http://www.kpm-usa.com>

Kawasaki Precision Machinery (Suzhou) Ltd.

668 Jianlin Rd., New District, Suzhou, 215151 China

Phone: 86-512-6616-0365 Fax: 86-512-6616-0366

Kawasaki Precision Machinery Trading (Shanghai) Co., Ltd.

17th Floor (Room 1701), The Headquarters Building, No168,

XiZang Road (M), Huangpu District, Shanghai 20001, China

Phone: 86-021-3366-3800 Fax: 86-021-3366-3808

Kawasaki Chunhui Precision Machinery (Zhejiang) Ltd.

No.200 Yasha Road, Shangyu Economic Development Zone, Shangyu,
Zhejiang, 312300, China

Phone: 86-(0)575-82156999 Fax: 86-(0)575-82158699

Flutek, Ltd.

192-11, Shinchon-dong, Changwon, Kyungnam, 641-370 Korea

Phone: 82-55-210-5900 Fax: 82-55-286-5557

Wipro Kawasaki Precision Machinery Private Limited

No. 15, Sy. No. 35 & 37, Kumbalgodu Industrial Area, Kumbalgodu Village,
Kengeri Hobli, Bangalore, - 560074, India

Kawasaki Heavy Industries, Ltd. Over sea network

KAWASAKI HEAVY INDUSTRIES, LTD.

OVERSEAS OFFICES

Beijing Office

Room No.2602, China World Tower 1, China World Trade Center, No.1 Jian Guo Men Wai Avenue, Beijing 100004, People's Republic of China
Phone: 86-10-6505-1350 Fax: 86-10-6505-1351

Taipei Office

15th Floor, Fu-Key Bldg., 99 Jen-Ai Road Section 2, Taipei, Taiwan
Phone: 886-2-2322-1752 Fax: 886-2-2322-5009

Moscow Office

6th Floor (605) Bol. Ovchinnikovskii, 16 Moscow, 115184 Russian Federation
Phone: 7-495-933-1953~1954 Fax: 7-495-933-1955

Delhi Office

5th Floor, Meridien Commercial Tower, 8 Windsor Place, Janpath, New Delhi, 100 001, India
Phone: 91-11-4358-3531 Fax: 91-11-4358-3532

OVERSEAS SUBSIDIARIES

Kawasaki Heavy Industries (U.S.A.), Inc.

599 Lexington Avenue, Suite 3901, New York, NY 10022, U.S.A.
Phone: 1-212-759-4950 Fax: 1-212-759-6421

Houston Branch

333 Clay Street, Suite 4310, Houston, TX 77002-4103, U.S.A.
Phone: 1-713-654-8981 Fax: 1-713-654-8187

Kawasaki do Brasil Indústria e Comércio Ltda.

Avenida Paulista 542-6 Andar, Bela Vista, 01310-000, Sao Paulo, S.P., Brazil
Phone: 55-11-289-2388 Fax: 55-11-289-2788

Kawasaki Heavy Industries (U.K.) Ltd.

4th Floor, 3, St. Helen's Place London EC3A 6AB, United Kingdom
Phone: 44-20-7588-5222 Fax: 44-20-7588-5333

Kawasaki Heavy Industries (Europe) B.V.

7th Floor, Riverstaete, Amsteldijk 166, 1079 LH Amsterdam, The Netherlands
Phone: 31-20-6446869 Fax: 31-20-6425725

Kawasaki Heavy Industries (H.K.) Ltd.

Room 4211-16, Sun Hong Kai Centre 30 Harbour Road, Wanchai Hong Kong
Phone: 852-2522-3560 Fax: 852-2845-2905

Kawasaki Heavy Industries (Singapore) Pte. Ltd.

6 Battery Road, #18-04, Singapore 049909
Phone: 65-62255133~4 Fax: 65-62249029

Kawasaki Heavy Industries (H.K.) Ltd.

Room 4211-16, Sun Hong Kai Centre 30 Harbour Road, Wanchai Hong Kong People's Republic of China
Phone: 852-2522-3560 Fax: 852-2845-2905

Kawasaki Heavy Industries Consulting & Service (Singapore) Company, Ltd.

13th Floor, HSBC Tower, 1000 Lujiazui Ring Road, Pudong New Area, Shanghai 200120, People's Republic of China
Phone: 86-21-6841-3377 Fax: 86-21-6841-2266